

# Horizontal heat recovery unit with dehumidifier, integration and ventilation unit with cooling circuit, and water coil

- cod. ACC200009 - cod. ACC200010

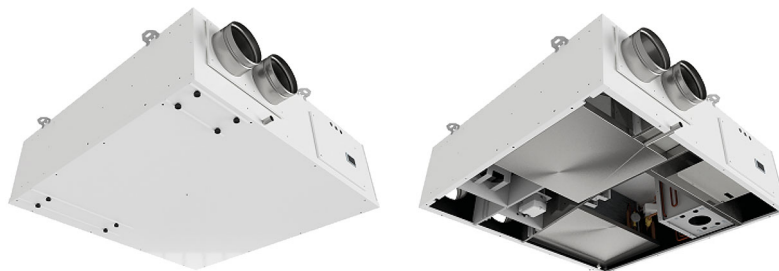

## TECHNICAL SPECIFICATIONS:

- Counter-flow heat recovery unit with >90% efficiency
- Flow rate 150 m<sup>3</sup>/h with 100 Pa of useful pressure in ventilation mode
- Dehumidification and integration with direct expansion refrigerant circuit
- Flow rate 300 m<sup>3</sup>/h with 100 Pa of useful pressure in ventilation + recirculation mode
- Flow rate 300 m<sup>3</sup>/h with 195 Pa of useful pressure in recirculation only mode
- Recovery unit by-pass damper (for free-cooling/free-heating) and integrated recirculation damper
- EC centrifugal fans, backward curved blades, low consumption
- F7 filters (ePM1 70%) with low pressure drop, both for extraction and renewal air
- Self-supporting structure in pre-painted sheet metal; thermal/acoustic insulation in expanded polyethylene thickness 10 mm
- Alphanumeric display on the machine
- Remote LCD display, with integrated temperature and humidity probes. Unit can be operated via remote contacts, remote display or via ModBus protocol on RS485

## DIMENSIONS MOD.150

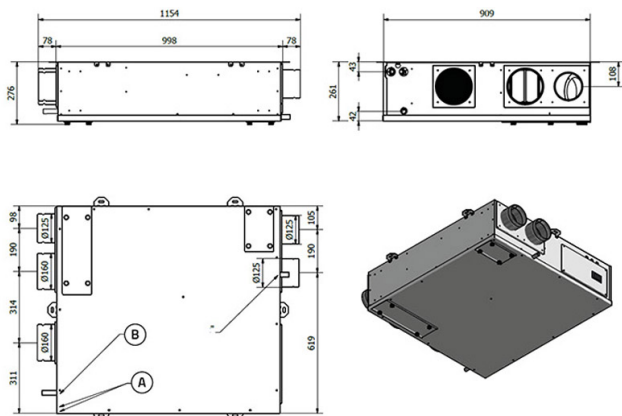

[A] Water coupling 1/2"  
 [B] Condensate drain 1/2"

## PERFORMANCE MOD. 150

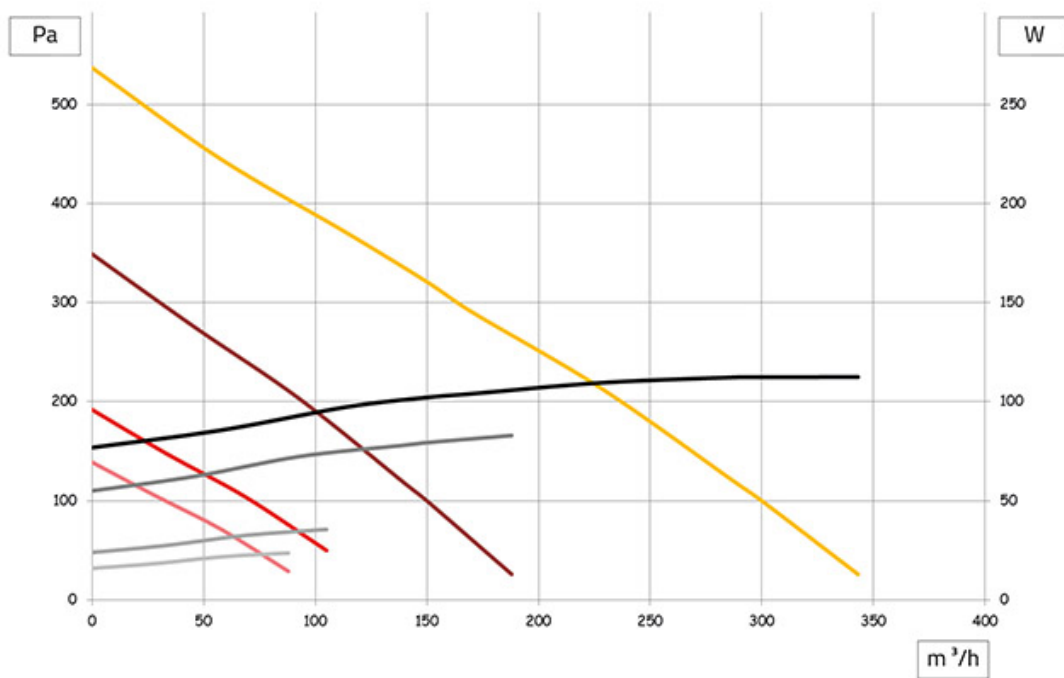

## THERMAL EFFICIENCY MOD. 150

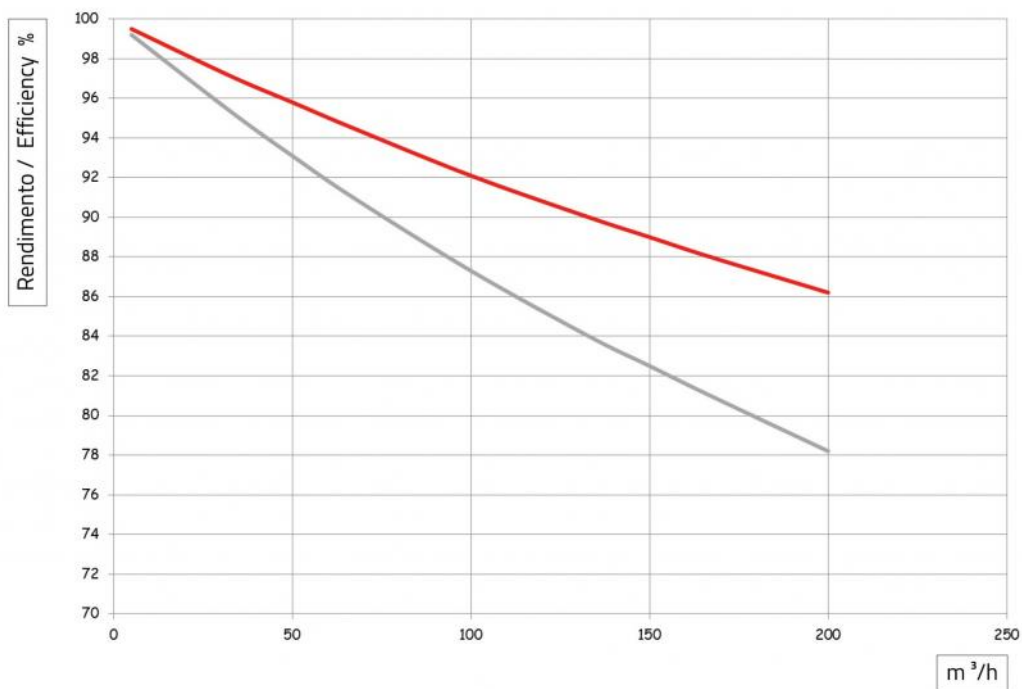

## DIMENSIONS MOD.250

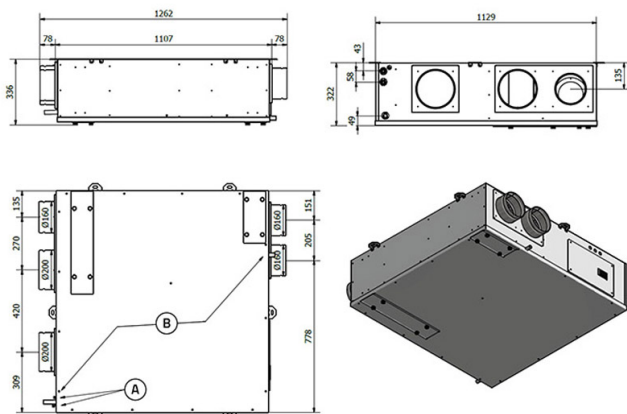

[A] Water coupling 1/2"  
[B] Condensate drain 1/2"

## PERFORMANCE MOD. 250

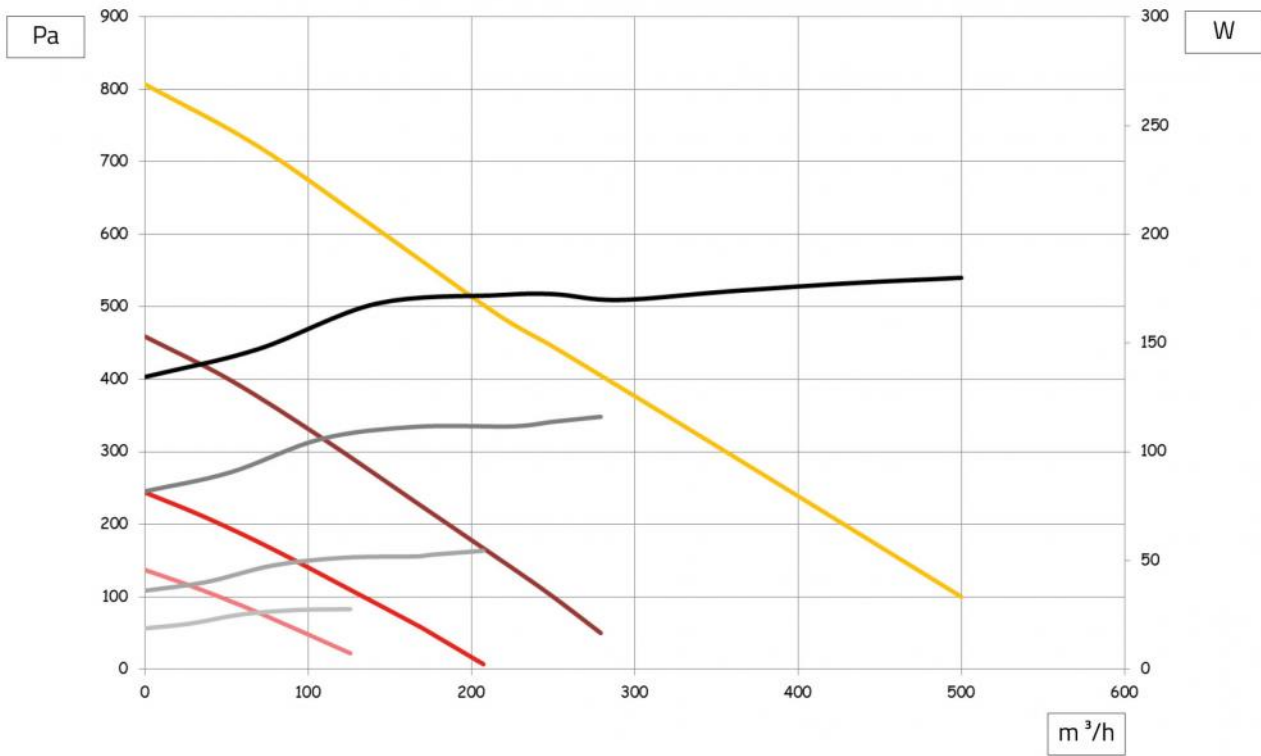

## THERMAL EFFICIENCY MOD. 250

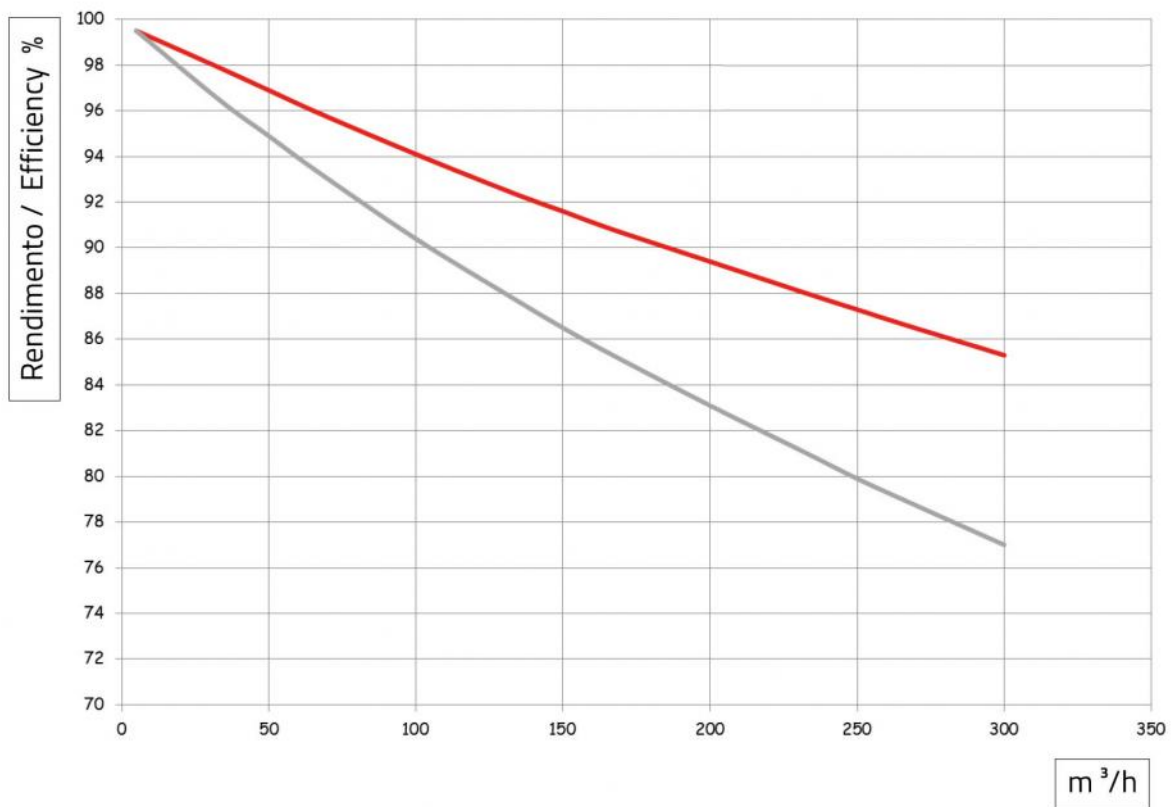

## VENTILATION MODE

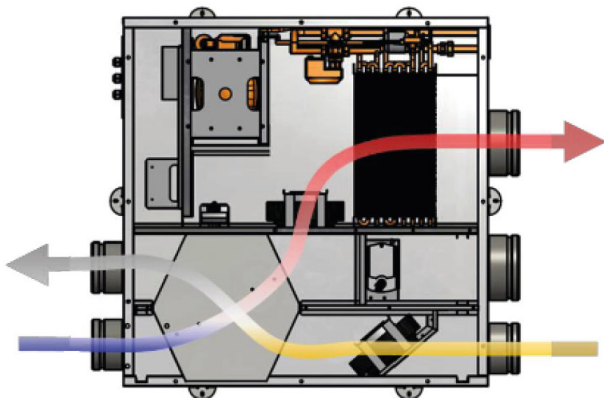

## VENTILATION

VENTILATION MODE	MODEL 150/300	MODELLO 250/500
Intake air flow rate [m³/h]	150	250
Recirculated air [m³/h]	0	
Available delivery head [Pa]	100	
Expulsion air flow rate [m³/h]	150	250
Available expulsion head [Pa]	100	
Fan setting speed [%]	78	70
Electrical power consumption [kW]	0,079	0,12
Current [A]	0,64	0,94

## DEHUMIDIFICATION/INTEGRATION (ventilation+recirculation)

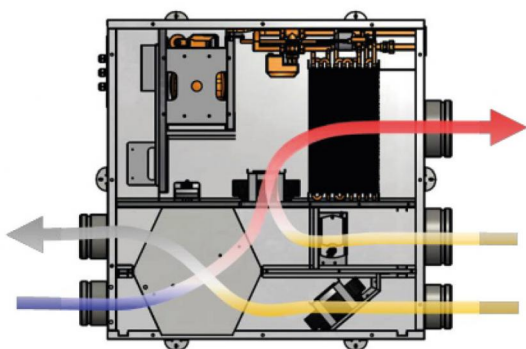

DEHUMIDIFICATION/INTEGRATION (ventilation+recirculation)	MODEL 150/300	MODELLO 250/500
Intake air flow rate [m³/h]	300	500
Recirculated air [m³/h]	150	250
Available delivery head [Pa]	100	
Expulsion air flow rate [m³/h]	150	250
Available expulsion head [Pa]	100	
Fan setting speed [%]	95/78	90/70

## COOLING AND DEHUMIDIFICATION

COOLING AND DEHUMIDIFICATION	MODEL 150/300	MODELLO 250/500
Ambient air	26°C e 60% U.R.	
Outside air	30°C and 60% U.R	
Cooling capacity [kW]	0,17 + 1,85	0,27 + 3,25
Refrigerant (R290) [gr]	55	120
Water temperature [°C]	15	
Water flow rate [l/h]	240	400
Load loss [kPa]	5	20
Electrical power consumption [kW]	0,11 + 0,22	0,18 + 0,39
Current [A]	0,92 + 1,3	1,5 + 2,0

## HEATING

HEATING	MODEL 150/300	MODELLO 250/500
Ambient air	20°C e 50% U.R.	
Outside air	-5°C e 80% U.R	
Heating capacity [kW]	1,13 + 1,39	1,85 + 2,33
Water temperature [°C]	35	
Water flow rate [l/h]	240	400
Load loss [kPa]	5	20
Power consumption (ventilation+compressor) [kW]	0,11 + 0,22	0,18 + 0,39
Current (ventilation+compressor) [A]	0,92 + 1,3	1,5 + 2,0

## DEHUMIDIFICATION/INTEGRATION (only recirculation)

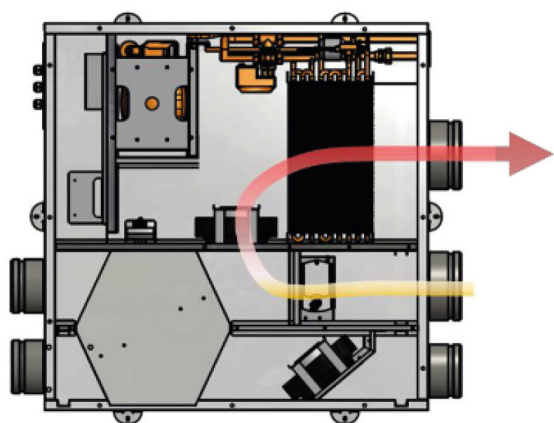

DEHUMIDIFICATION/INTEGRATION (only recirculation)	MODEL 150/300	MODELLO 250/500
Intake air flow rate [m³/h]	300	500
Recirculated air [m³/h]	300	500
Available delivery head [Pa]	195	215
Expulsion air flow rate [m³/h]	0	
Available expulsion head [Pa]	100	
Fan setting speed [%]	95/0	90/0

## COOLING AND DEHUMIDIFICATION

COOLING AND DEHUMIDIFICATION	MODEL 150/300	MODELLO 250/500
Ambient air	26°C e 60% U.R.	
Outside air	30°C and 60% U.R	
Cooling power [kW] (refrigerant circuit only)	1,71	2,77
Refrigerant (R290) [gr]	55	120
Water temperature [°C]	15	
Water flow rate [l/h]	240	400
Load loss [kPa]	5	20
Condensing capacity [l/h]	0,96	1,54

## HEATING

HEATING	MODEL 150/300	MODELLO 250/500
Ambient air	20°C e 50% U.R.	
Outside air	-5°C e 80% U.R	
Heating capacity (cooling circuit only) [kW]	1,16	2,14
Water temperature [°C]	35	
Water flow rate [l/h]	240	400
Load loss [kPa]	5	20
Power consumption (ventilation+compressor) [kW]	0,075 + 0,22	0,12 + 0,39
Current (ventilation+compressor) [A]	0,64 + 1,3	1,0 + 2,0

## LCD REMOTE DISPLAY

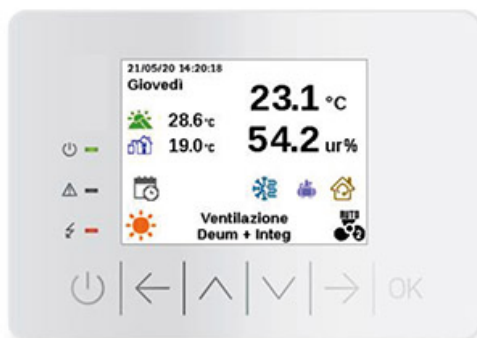



16-Colour LCD screen with 320x240 pixels, with 6-key touch keypad.

The terminal also incorporates a temperature and humidity sensor, the readings from this sensor are transmitted directly via the CAN bus, thus simplifying wiring.

- Power supply: 24 VAC/12... 30 VDC
- Max power supply length: 10m
- T sensor: built-in
- Temperature of use: 10°C to 55°C
- ur sensor: built-in
- Humidity of use: From 5 to 95%
- Warning buzzer: built-in
- Protection class IP30

## CONNECTION DIAGRAM DISPLAY

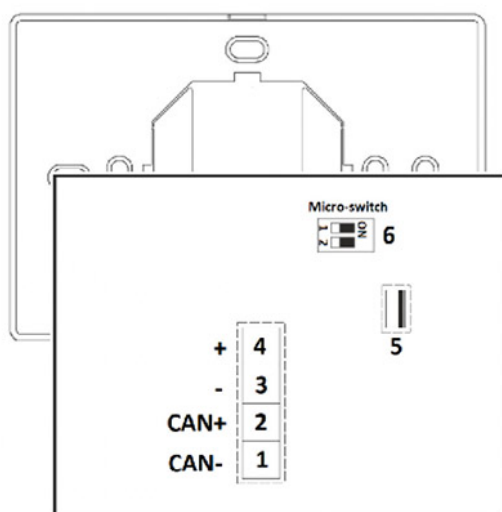

[1] CAN port reference

[2] Reference + CAN port

[3] Device power supply (24 VAC/12... 30 VDC); if the device is powered by direct current, connect the negative terminal.

[4] Device power supply (24 VAC/12... 30 VDC); if the device is powered by direct current, connect the positive terminal.

[5] USB port, for the programming of the device.

[6] Micro switch for inserting the heating element of termination of the CAN port.

## ENERGY RATING MOD. 150

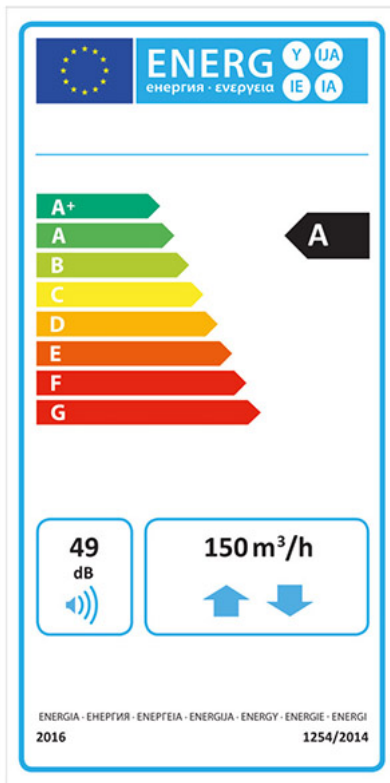

SPECIFICATIONS	DATA
Specific energy consumption in kWh/(m <sup>2</sup> .a) for each climate zone and SEC class	Cold climate: -74.8 kWh/m <sup>2</sup> .a; Mild climate -36,7 kWh/m <sup>2</sup> .a; Warm climate: -12.2 kWh/m <sup>2</sup> .a
Energy rating	A
Product type	Bidirectional UVR
Type of drive	Variable speed
Heat recovery system	Counter-current heat recovery unit
Thermal efficiency of the heat recovery [%]	86,8
Maximum flow rate [m <sup>3</sup> /h]	150
Electrical power input at maximum flow rate [W]	82
Sound power level [db(A)]	49
Reference flow rate [m <sup>3</sup> /s]	0,029
Pressure difference [Pa]	50
Specific power consumption (W/[m <sup>3</sup> /h])	0,37
Type of control	Centralised environmental control
Control coefficient	0,85
Leakage rate [%]	internal: 3.7 - external: 5.9 - recirculation: not applicable
Mix rate [%]	not applicable
Location and description of the visual warning sign for the filters	Alarm displayed on the on-board control unit and on the dedicated remote display, as well as signalling via Modbus and with configurable alarm contact
Installation for new air delivery	not applicable
Sensitivity of air flow to pressure changes at + 20 Pa and -20 Pa [%]	not applicable
Indoor/Outdoor air seal [m3/h]	not applicable
Specific annual electricity consumption (AEC) for a dwelling measuring 100m <sup>2</sup> (kWh electricity /a)	Cold climate: 914.7 kWh elect./a; Mild climate: 377.7 kWh elect./a; Warm climate: 332.7 kWh elect./a
Specific annual heat savings for a dwelling measuring 100m <sup>2</sup> (kWh of primary energy /a)	Cold climate: 8776.2 kWh prim./a; Mild climate: 4486.2 kWh prim./a; Warm climate: 2028.6 kWh prim./a

## ENERGY RATING MOD. 250

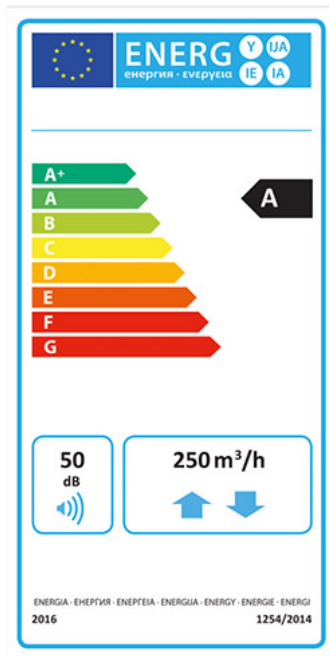

SPECIFICATIONS	DATA
Specific energy consumption in kWh/(m <sup>2</sup> .a) for each climate zone and SEC class	Cold climate: -74.8 kWh/m <sup>2</sup> .a; Mild climate -37,2 kWh/m <sup>2</sup> .a; Warm climate: -13.1 kWh/m <sup>2</sup> .a
Energy rating	A
Product type	Bidirectional UVR
Type of drive	Variable speed
Heat recovery system	Counter-current heat recovery unit
Thermal efficiency of the heat recovery [%]	84,7
Maximum flow rate [m <sup>3</sup> /h]	250
Electrical power input at maximum flow rate [W]	117
Sound power level [db(A)]	50
Reference flow rate [m <sup>3</sup> /s]	0,049
Pressure difference [Pa]	50
Specific power consumption (W/[m <sup>3</sup> /h])	0,32
Type of control	Centralised environmental control
Control coefficient	0,85
Leakage rate [%]	internal: 4.0 - external: 6.1 - recirculation: not applicable
Mix rate [%]	not applicable
Location and description of the visual warning sign for the filters	Alarm displayed on the on-board control unit and on the dedicated remote display, as well as signalling via Modbus and with configurable alarm contact
Installation for new air delivery	not applicable
Sensitivity of air flow to pressure changes at + 20 Pa and -20 Pa [%]	not applicable
Indoor/Outdoor air seal [m3/h]	not applicable
Specific annual electricity consumption (AEC) for a dwelling measuring 100m <sup>2</sup> (kWh electricity /a)	Cold climate: 869.6 kWh elect./a; Mild climate: 332.6 kWh elect./a; Warm climate: 287.6 kWh elect./a
Specific annual heat savings for a dwelling measuring 100m <sup>2</sup> (kWh of primary energy /a)	Cold climate: 8887.4 kWh prim./a; Mild climate: 4543.0 kWh prim./a; Warm climate: 2054.3 kWh prim./a

## ITEMS

CODE	DESCRIPTION
ACC200009	HEAT RECOVERY UNIT W/DEHUMIDIFY UNIT, INTEGRATION AND VENTILATION WUTH REFRIGERANT CIRCUIT AND WATER COIL, REFRIGERATION CIRCUIT INTEGRATION AND VENTILATION AND WATER COIL- 150/300
ACC200010	HEAT RECOVERY UNIT W/DEHUMIDIFY UNIT, INTEGRATION AND VENTILATION WUTH REFRIGERANT CIRCUIT AND WATER COIL, REFRIGERATION CIRCUIT INTEGRATION AND VENTILATION AND WATER COIL- 250/500

All rights relating to this publication are the exclusive property of Tecnosystemi SpA.

Tecnosystemi SpA reserves the right to make changes at any time and without notice, for technical or commercial needs.