

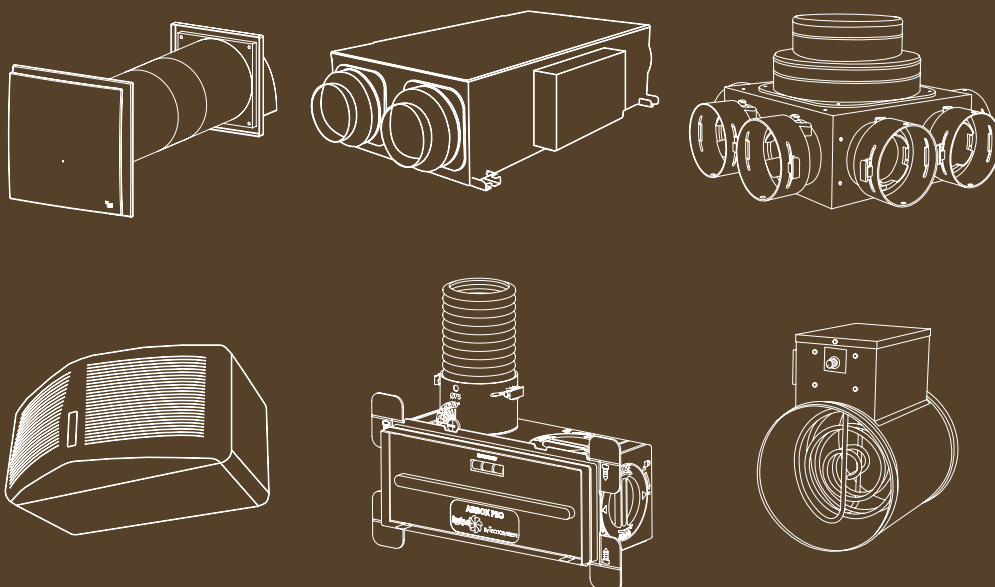



Apply.Co

Mechanical Ventilation Heat Recovery



Apply.Co is for installers and designers who intend to create valuable MVHR systems by combining high efficiency heat recovery units (from 75% to 90%) with air diffusion elements, using accessories that are easy and quick to install.

The use of high quality components and machines allow for excellent results in terms of performance and comfort.

PRODUCT INDEX

12

Built-in static extractors
"PICO BASIC" - "PICO PRO"
"PICO PRO +"



30

Built-in and wall-mounted
ductable static heat recovery
UNIT "AIR PUR 3 PLUS WI, WI-C"



37

Wall-mounted residential
heat recovery unit
"SILENCE AIR PLUS"



40

Compact heat recovery unit
"COMPACT 30"



42

Analysable high-efficiency
ceiling-mounted static
heat recovery unit
"TOTAL AIR 200"



46

Ventilation unit with
heat recovery
"TS-HRVU"



53

"TOTAL CLASS" non-ducted
ventilation unit with
horizontal/vertical structure

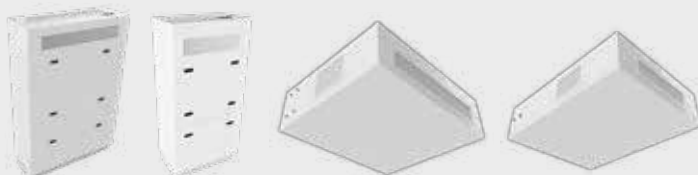

57

Ceiling-mounted ductable
static heat recovery unit
"AIR PUR EVO PLUS"



60

Ceiling-mounted ductable
static heat recovery
unit "AIR PUR EVO"



63

Static wall ductable heat
recovery unit with high vertical
efficiency "TOTAL AIR EVO PLUS"
200/300 /500



65

The enthalpic heat recovery can be ceiling unit ductable "HI-TECH PUR 4.0"



68

Metal sheet insulated ductable box equipped with bactericidal sanitising lamp, single phase speed regulator, probe for heat recovery system



77

EPS tubes and accessories
Round flexible hose air inlet anti-static and accessories

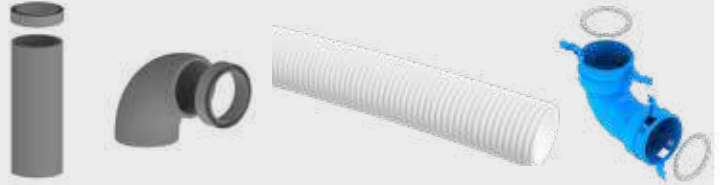

80

Air inlet flexible hose and accessories



85

Delivery/intake box in PAL for custom MVHR and accessories



94

Stainless steel grills ceiling / wall / floor plenum MVHR kit



98

Plastic plenum for MVHR
Grills for plastic plenum MVHR



102

Extractor tower



104

In line fans
Ductable aspirators with vertical / side outlet



110

Electric extractor



RANGE OF TECNOSYSTEMI HEAT RECOVERY UNITS



WALL-MOUNTED POINT RECOVERY UNITS

			
PICO	AIR PUR 3 PLUS	SILENCE AIR	TOTAL CLASS
From 30 to 60 m ³ /h	From 160 to 300 m ³ /h	150 m ³ /h	400 and 1000 m ³ /h
Class A	Class A	Class A	Efficiency 83%
Alternating flows	Cross flows	Cross flows	Cross flows
Wall	Wall	Wall	Wall/Ceiling
		BMS	BMS

CEILING-DUCTED

		
COMPACT 30	TOTAL AIR 200	TS-HRVU
100 m ³ /h	215 m ³ /h	From 120 to 500 m ³ /h
Class B	Class A	Class A
Cross flows	Cross flows	Cross flows
Analogue control	Electronic control	Digital control
	BMS	BMS
		
AIR PUR EVO PLUS	AIR PUR EVO	HI TECH PUR 4.0
From 300 to 4000 m ³ /h	From 300 to 4000 m ³ /h	From 250 to 1300 m ³ /h
Efficiency 75%	Efficiency 75%	Efficiency from 73% to 76%
Cross flows	Cross flows	Cross flows
Electronic control	Analogue control	Electronic control
BMS		BMS

WALL-MOUNTED DUCTED

	
TOTAL AIR EVO PLUS	TS-HRVU
from 300 to 475 m ³ /h	From 120 to 500 m ³ /h
Class B	Class A
Cross flows	Cross flows
Electronic control	Digital control
	BMS

CANALIZABLE HEAT RECOVERY UNIT WITH DEHUMIDIFICATION FUNCTION



WITH DEHUMIDIFICATION
Unit from 150 to 500 m ³ /h
Class A
Cross flows
Electronic control
BMS



THE ADVANTAGES TO CHOOSE THE MVHR

✓ IMPROVES INDOOR AIR QUALITY

Indoor air quality (IAQ) refers to the indoor air breathed in confined spaces, such as:



Public and/or private means of transport (car, train, plane, ship, etc.)



Community facilities (hospitals, schools, offices, barracks, hotels, banks)



Homes, public and private offices



Environments intended for recreational and social activities (cinemas, bars, restaurants, shops, sports facilities)

Thanks to the ventilation it is possible to renew the stale air of an environment, replacing it with cleaner air and to reduce the concentration of harmful substances produced by internal sources; moreover it is also possible to eliminate the excess water vapour;

Room ventilation therefore plays an important role in ensuring good indoor air quality and relative humidity (or hygrometric degree) provides useful information on room ventilation.

✓ ENERGY & MONEY SAVING

Thanks to Tecnosystemi's MVHR products we have improved air quality, saving money!

Mechanical controlled ventilation systems allow constant and continuous air exchange, permit the house to breathe without having to open the windows. This makes it possible to limit **heat loss (energy saving) and mould; the indoor air is filtered and makes the environment optimal for allergy sufferers.**



THE EUROPEAN DIRECTIVES ERP DIRECTIVE

The Tecnosystemi products comply with the ERP ECODESIGN Directive (Energy Related Products) 2009/125/EC.

The European Union has undertaken, with the adoption of the Kyoto protocol, to reduce CO₂ emissions by at least 20% by 2020. To achieve this goal, the ErP Directive 2009/125/EC (**Energy related Products Directive**), also called the Ecodesign Directive, was introduced in 2009, which aims to establish a framework for the development of Community specifications for the eco-compatible design of products connected to energy.





BUILT-IN STATIC HEAT RECOVERY UNITS



RÉCUPÉRATEUR DE CHALEUR INTÉGRÉ ET MURAL



UNTERPUTZ EINGEBAU-TE DEZENTRALE WAR-MERÜCKGEWINNUNGS-EINHEIT

PICO

Built-in static aspirators and extractors with heat recovery punctual

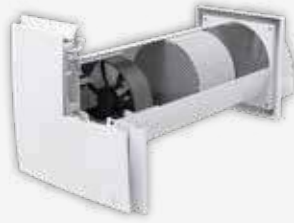

PICO BASIC 60



PICO BASIC 30



PICO PRO 45



PICO PRO PLUS 60



AirPur3^{PLUS} wi



Heat recovery built-in static



BUILT-IN STATIC HEAT RECOVERY UNITS



ASPIRATEUR - EXTRACTEUR STATIQUE INTÉGRÉ AVEC RÉCUPÉRATION DE CHALEUR



EINGEBAU-TE ZENTRALE WÄRMERÜCKGEWINNUNGS-EINHEIT



MOD. 160



MOD. 230



MOD. 300

NOW IT'S EASIER WITH THE NEW SOLUTIONS "SINGLE ROOM"



AirPur3^{PLUS}
wi



Heat recovery
wall statics

 BUILT-IN STATIC
EXTRACTORS
HEAT RECOVERY UNITS

 RÉCUPÉRATEUR
DE CHALEUR
INTÉGRÉ ET MURAL

 ZENTRALE WÄRME
RÜCKGEWINNUNGS-EINHEIT



MOD. 160



MOD. 230



MOD. 300



TECNOSYSTEMI INTRODUCES THE NEW STATIC WALL-MOUNTED ASPIRATOR-EXTRACTOR WITH PUNCTUAL HEAT RECOVERY

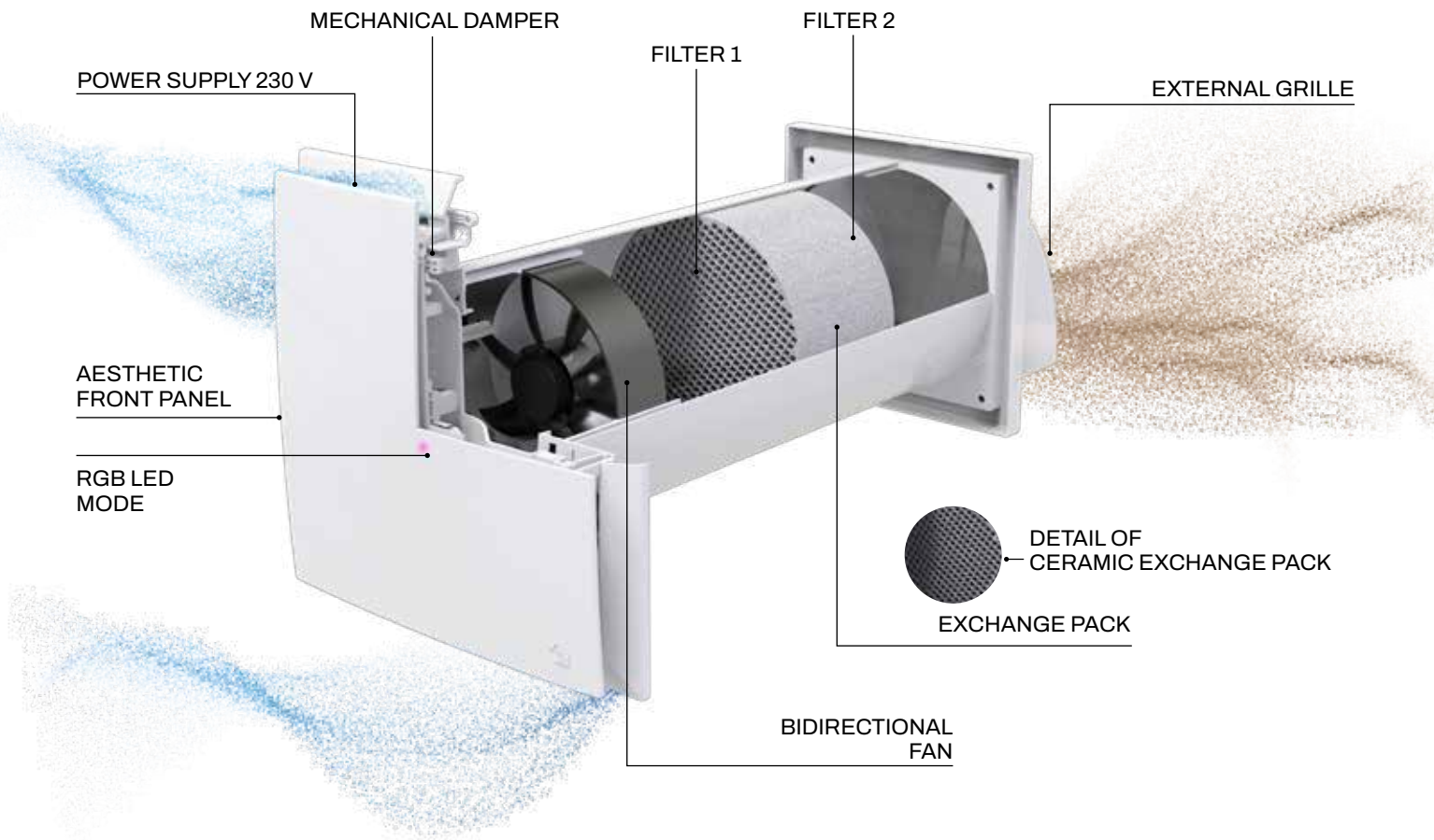
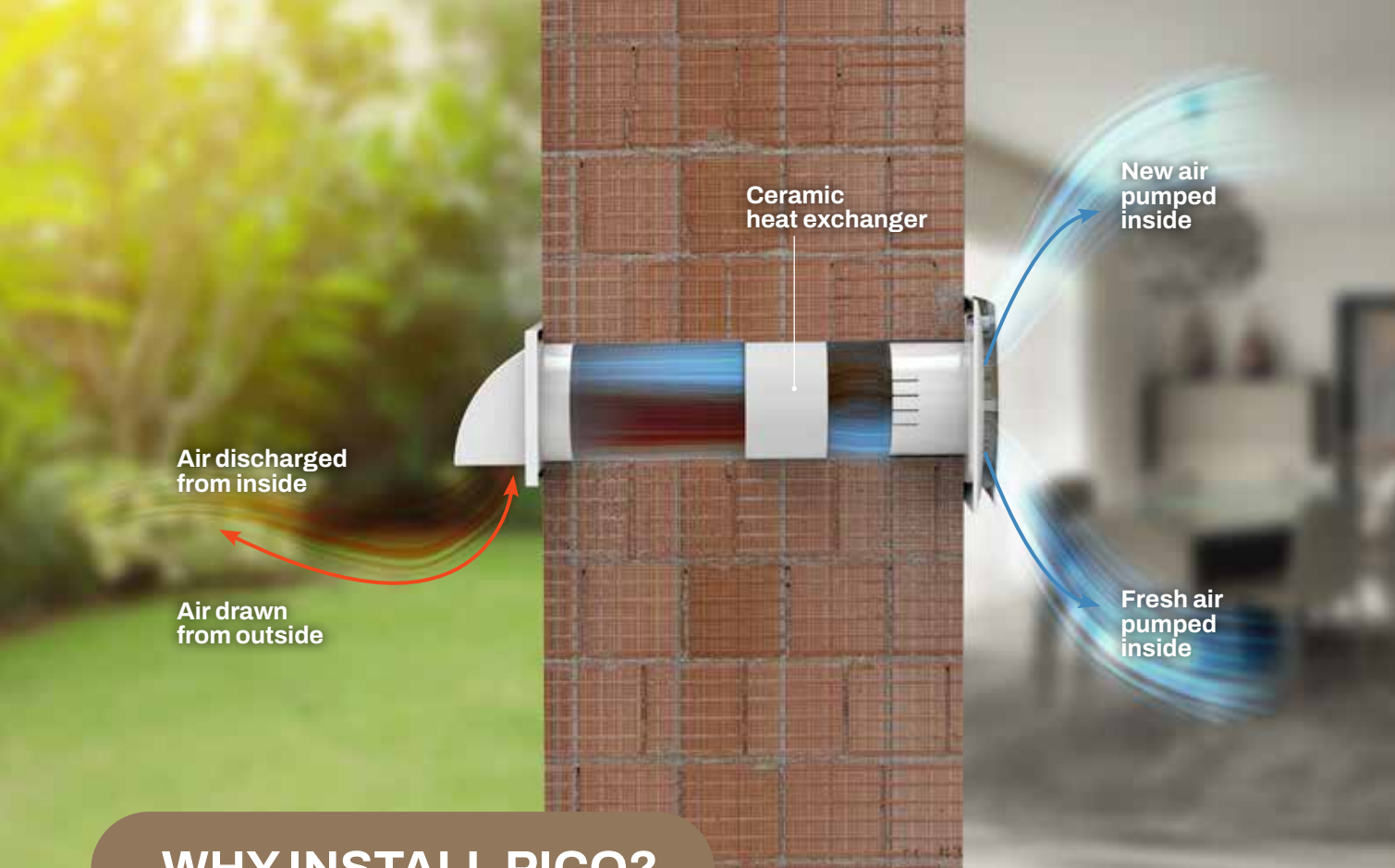

Image referring to PICO BASIC, PICO PRO, PICO PRO +





WHY INSTALL PICO?

PICO PRO is an innovative system designed to improve thermal comfort and indoor air quality in residential houses.

PICO is capable of operating in both directions, which means it can be used to ventilate and recover room heat as required. **This allows maintaining a comfortable microclimate in all seasons.**



Energy saving

This system is designed to maximise energy savings, thus reducing the costs associated with heating and cooling indoor spaces. Its efficient operation helps to reduce environmental impact



Optimised ventilation

PICO ensures effective ventilation and adequate air exchange within rooms, improving air quality and contributing to the well-being of occupants



High performance

The aspirator-extractor integrated in PICO offers high efficiency, with an extraction capacity of up to 90%. This is made possible by the presence of a honeycomb heat exchanger made of ceramic material, which maximises thermal efficiency





Easy installation and maintenance

PICO is designed for easy installation and maintenance. This simplifies the management of the system by reducing maintenance costs over time

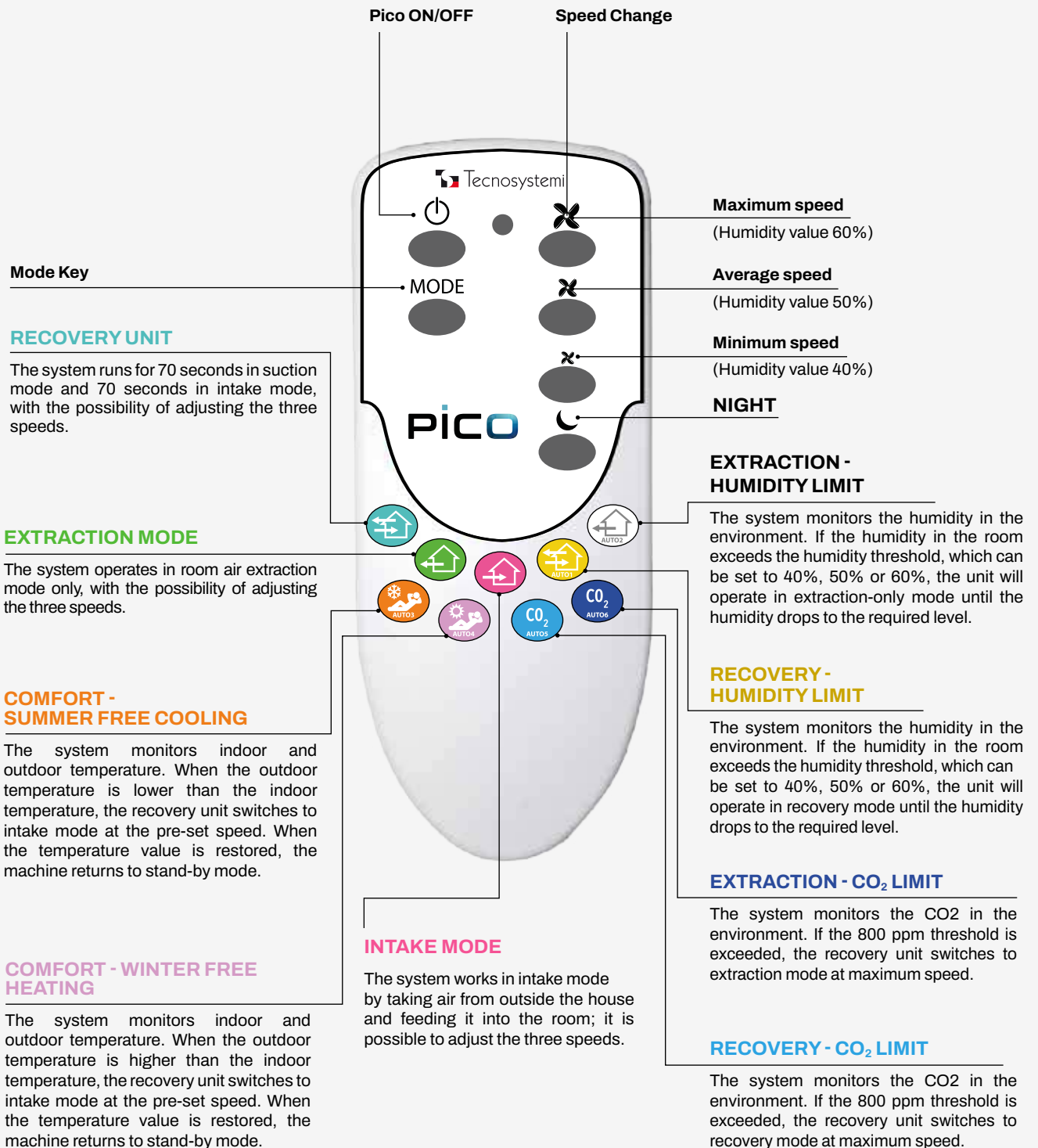
REMOTE CONTROL INCLUDED



NEW APPLICATION NEW FUNCTIONALITIES

-  Local or remote control
-  Speed modulation
-  Night mode for better sleep

FREE APP AVAILABLE ON:



VOICE COMMANDS:



Tecnosystemi

Apply.co



PICO

BREATH FRESH AIR!

Prevent mould and humidity...
avoiding unnecessary costs and
improving the quality of your life!



THE SOLUTION YOU WERE LOOKING FOR!

PICO^{*}
basic

PICO
pro

PICO
pro+

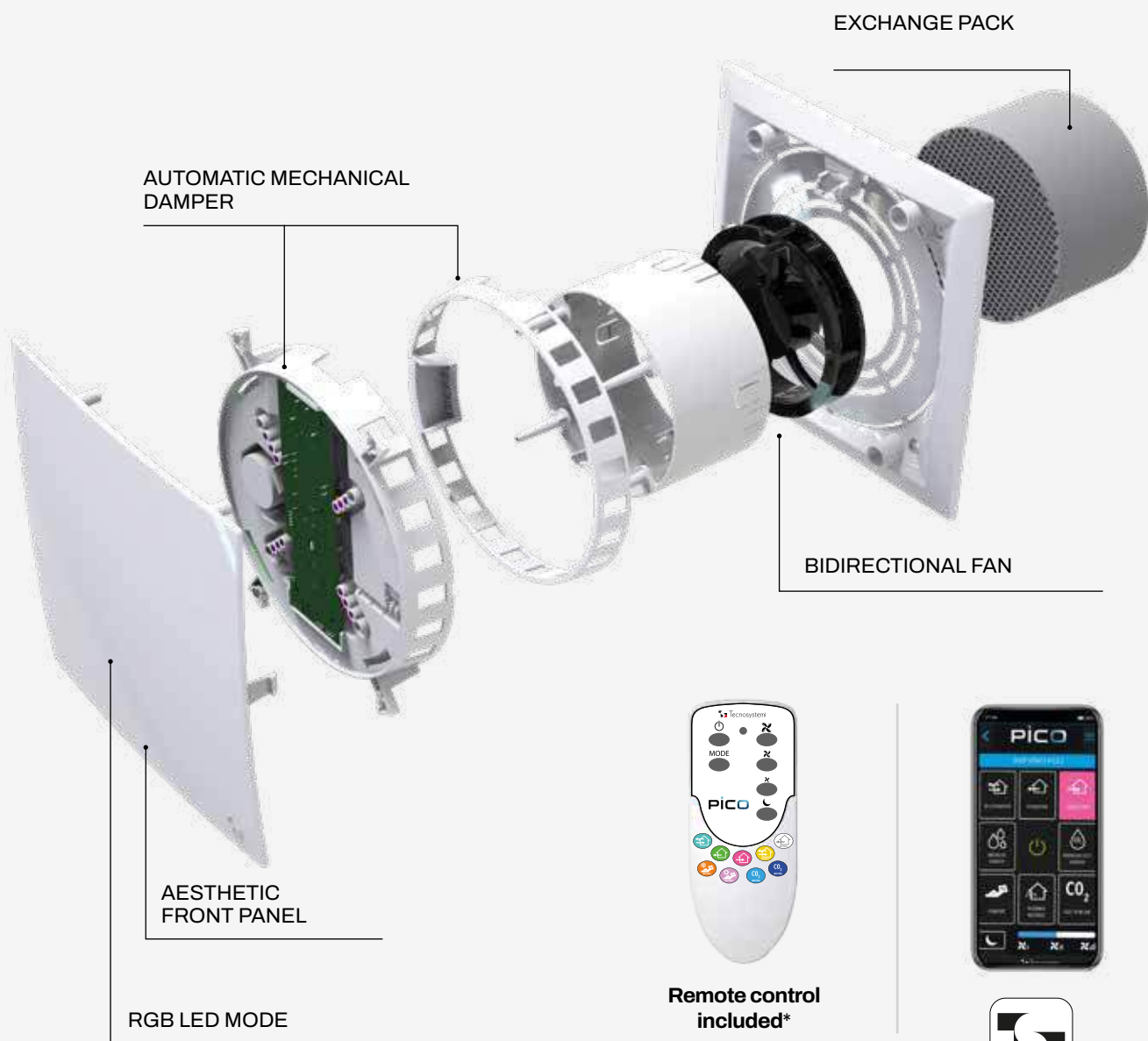

Remote control included*



Tecosystemi

FREE APP
AVAILABLE ON:



VOICE COMMANDS:



* The PICO BASIC model is not equipped with an automatic damper or remote control

MODELLI A CONFRONTO

Model		Remote control icons	App icons	Pico Basic	Pico Pro	Pico Pro+	
Recovery unit				•	•	•	
Extraction unit				•	•	•	
Intake mode				•	•	•	
Humidity limit	Recovery unit			•	•	•	
	Extractor			•	•	•	
Ricircolo Naturale		-		-	•	•	
Free Cooling				-	-	•	
Free Heating				-	-	•	
CO ₂ limit	Recovery unit			-	-	•	
	Extractor			-	-	•	
CO ₂ humidity limit	Recovery unit	-		-	-	•	
	Extractor	-		-	-	•	
Night mode				•	•	•	
Master Slave		•	•	•	•	•	
Filter		2 x G2					
M ³ /h max		30 - 45 - 60					
Automatic damper		-				•	•
Finish		White matt					
Remote control		-				•	•
Home Assistant		Compatible with Alexa and Google Home					

LEGEND: • function available
- function not available



OPERATING MODES



REGENERATOR

The air flow is alternated and it is possible to adjust the three speeds.

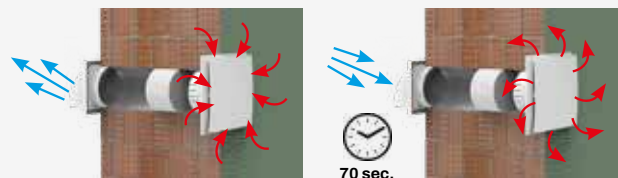

EXTRACTION

The device works in internal air extraction mode only, with the option to regulate the three speeds.

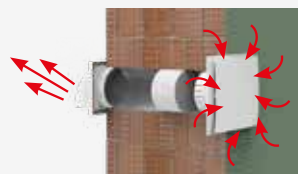

AERATION

The recuperator works in aeration mode only and it is possible to adjust the three speeds.

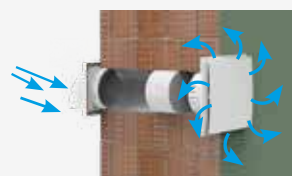

HUMIDITY LIMIT RECOVERY

When the air in the room exceeds the humidity level, that can be set at 40%, 50% or 60%, the device goes onto recovery mode until the humidity recovers according to the set value.

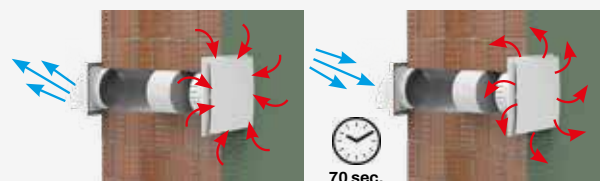

HUMIDITY LIMIT EXTRACTION

The system monitors the humidity of the environment. When the air in the room exceeds the humidity limit which can be set at 40%, 50% or 60%, the appliance activates in extraction only mode until the humidity is brought back within the required value.

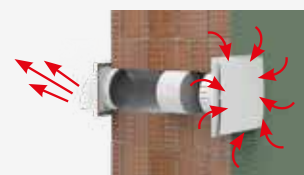

SUMMER COMFORT FREE COOLING

If, when comparing the external and internal temperatures, it is verified that the external value is lower than the internal one, the recuperator switches to medium speed input mode.

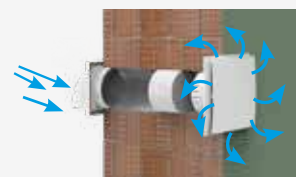

DESCRIPTION	REGENERATOR	EXTRACTION	AERATION	SETTING HUMIDITY VALUE	Wi-Fi	AUTO 1	AUTO 2	AUTO 3
PICO BASIC 30	•	•	•	•	•	•	•	
PICO BASIC 45	•	•	•	•	•	•	•	
PICO BASIC 60	•	•	•	•	•	•	•	
PICO PRO 30	•	•	•	•	•	•	•	
PICO PRO 45	•	•	•	•	•	•	•	
PICO PRO 60	•	•	•	•	•	•	•	
PICO PRO+ 30	•	•	•	•	•	•	•	•
PICO PRO+ 45	•	•	•	•	•	•	•	•
PICO PRO+ 60	•	•	•	•	•	•	•	•



WINTER COMFORT FREE HEATING

If the external temperature is higher than the internal one, the recuperator switches to input mode at medium speed. The LED remains pink.

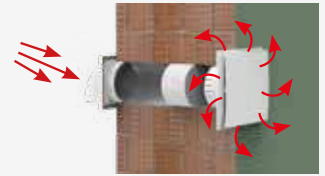

CO₂ LIMIT RECOVERY

The extraction ventilation is activated at minimum to detect the CO₂ value of the internal room. When the CO₂ limit is exceeded, the recuperator switches to recovery mode at maximum speed. The factory set CO₂ value is 800ppm.

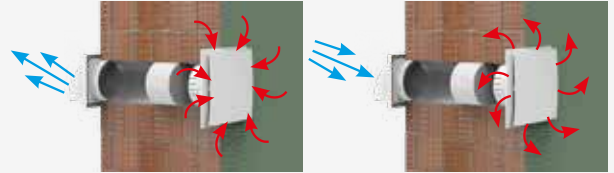

CO₂ LIMIT EXTRACTION

Extraction ventilation is activated at minimum to detect the CO₂ value of the internal room. When the CO₂ limit is exceeded, the recuperator switches to extraction mode at maximum speed. The factory set CO₂ value is 800 ppm.

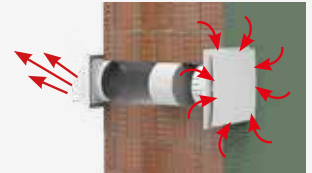

HUMIDITY LIMIT EXTRACTION + CO₂ (only from app)

The extraction ventilation is activated at minimum to detect the CO₂ and humidity value of the internal room. When the CO₂ and humidity limits are exceeded, the recuperator switches to recovery mode at maximum speed.



HUMIDITY LIMIT RECOVERY + CO₂ (only from app)

Extraction ventilation is activated at minimum to detect the CO₂ and humidity value of the internal room. When the CO₂ and humidity limits are exceeded, the recuperator switches to extraction mode at maximum speed.



NATURAL EXCHANGE (only from app)

The damper is opened without activating the fans.



NIGHT MODE

Once selected, night mode turns off the LED and sets the super minimum speed.

AUTO 4	AUTO 5	AUTO 6	AUTO 7	AUTO 8	NATURAL EXCHANGE	DAMPER	MASTER / SLAVE	NIGHT MODE	INDICATION FILTERS MAINTENANCE
								•	•
								•	•
								•	•
					•	•	•	•	•
					•	•	•	•	•
					•	•	•	•	•
•	•	•	•	•	•	•	•	•	•
•	•	•	•	•	•	•	•	•	•
•	•	•	•	•	•	•	•	•	•

 **VENTILATION UNIT WITH WALL-MOUNTED PUNCTUAL HEAT RECOVERY, WITHOUT REMOTE CONTROL**

TECHNICAL SPECIFICATIONS

- For wall installation
- Front wall thickness 35 mm
- Available with flow rates from 30 to 60 m³/h
- Energy Class A
- Wi-fi control mode 2.4 GHz via APP: local or remote connection
- Integration Voice assistants and Google Home
- Functions: Comfort - Humidity threshold - Natural recirculation - Night mode
- Heat exchanger made of high-efficiency ceramic
- Built-in grade G2 filters
- Fan with low energy consumption

 **UNITÉ DE VENTILATION AVEC RÉCUPÉRATION DE CHALEUR PONCTUELLE MURALE, SANS TÉLÉCOMMANDE**

CARACTÉRISTIQUES TECHNIQUES

- Pour l'installation murale
- Épaisseur frontale du mur 35 mm
- Disponible avec des débits de 30 à 60 m³/h
- Classe énergétique A
- Mode de contrôle Wi-fi 2.4 GHz via APP : connexion locale ou à distance
- Intégration Assistants vocaux et Google Home
- Fonctions : Confort - Seuil d'humidité - Circulation naturelle - Mode nuit
- Échangeur de chaleur en céramique à haute efficacité
- Filtres de qualité G2 intégrés
- Ventilateur à faible consommation d'énergie

 **DEZENTRALE WÄRMERÜCKGEWINNUNG-EINHEIT ZUR WANDMONTAGE, OHNE FERNBEDIENUNG**

TECHNISCHE EIGENSCHAFTEN

- Zur Wandmontage geeignet
- Frontdicke 35 mm
- Erhältlich mit Durchflussraten von 30 bis 60 m³/h
- Energieeffizienzklasse A
- 2.4 GHz WiFi-Steuerungsmodus per APP: lokale oder Remote-Verbindung
- Integration Sprachassistenten und Google Home
- Funktionen: Komfort - Feuchtigkeitsschwelle - Natürliche Zirkulation - Nachtmodus
- Wärmetauscher aus hocheffizientem Keramikmaterial
- Eingebaute Filter, Grad G2
- Lüfter mit geringem Energieverbrauch

A

PICO
basic



Virtual reality



FREE APP AVAILABLE ON



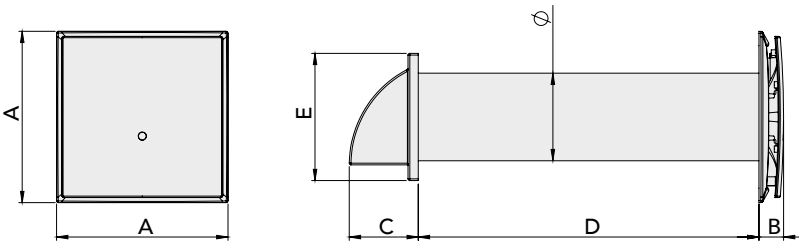

DIMENSIONS AND MODELS	A [mm]	B [mm]	C [mm]	D [mm]	E [mm]	Ø [mm]
PICO BASIC 30	250	35	86	500	154	103
PICO BASIC 45	250	35	101	500	186	128
PICO BASIC 60	250	35	101	500	186	153

PICO BASIC 30



TECHNICAL DATA	STANDBY	NIGHT		MIN. 1 SPEED		MIN. 2 SPEED		MIN. 3 SPEED	
MODE	-	Extraction	Ventilation	Extraction	Ventilation	Extraction	Ventilation	Extraction	Ventilation
CONSUMPTION [W]	<1W	1.5 W	1.5 W	2 W	2 W	3 W	3 W	4 W	4 W
AIR FLOW RATE [M ³ /H]	-	6	6	10	10	18	20	26	30
SOUND POWER [DB(A)]	-	18	19	22	23	26	27	29	32
SEC ENERGY CLASS	A								
TYPE	UVR Dual Flow								
TYPE OF HEAT RECOVERY UNIT	Regenerative type HRC3b								
FILTRATION CLASS	G2								

PICO BASIC 45

TECHNICAL DATA	STANDBY	NIGHT		MIN. 1 SPEED		MIN. 2 SPEED		MIN. 3 SPEED	
MODE	-	Extraction	Ventilation	Extraction	Ventilation	Extraction	Ventilation	Extraction	Ventilation
CONSUMPTION [W]	<1W	1.5 W	1.5 W	2 W	2 W	3 W	3 W	4.5 W	4.5 W
AIR FLOW RATE [M ³ /H]	-	8	8	21	22	28	32	40	45
SOUND POWER [DB(A)]	-	20	22	24	27	28	30	35	37
SEC ENERGY CLASS	A								
TYPE	UVR Dual Flow								
TYPE OF HEAT RECOVERY UNIT	Regenerative type HRC3b								
FILTRATION CLASS	G2								

PICO BASIC 60

TECHNICAL DATA	STANDBY	NIGHT		MIN. 1 SPEED		MIN. 2 SPEED		MIN. 3 SPEED	
MODE	-	Extraction	Ventilation	Extraction	Ventilation	Extraction	Ventilation	Extraction	Ventilation
CONSUMPTION [W]	<1W	1.7 W	1.7 W	3 W	3 W	4.5 W	4.5 W	7 W	7 W
AIR FLOW RATE [M ³ /H]	-	11	11	32	30	46	40	65	60
SOUND POWER [DB(A)]	-	24	28	30	32	35	38	40	41
SEC ENERGY CLASS	A								
TYPE	UVR Dual Flow								
TYPE OF HEAT RECOVERY UNIT	Regenerative type HRC3b								
FILTRATION CLASS	G2								

CODE	DESCRIPTION	U.M.	 Pieces per box	 U.M. Box	 U.M. Pallet
ACD100060	HEAT RECOVERY UNIT - PICO BASIC 30	PCS	1	1	12
ACD100061	HEAT RECOVERY UNIT - PICO BASIC 45	PCS	1	1	12
ACD100062	HEAT RECOVERY UNIT - PICO BASIC 60	PCS	1	1	12

[Datasheet](#)

 **VENTILATION UNITS WITH WALL-MOUNTED PUNCTUAL HEAT RECOVERY**

TECHNICAL SPECIFICATIONS

- For wall installation
- Front wall thickness 35 mm
- Available with flow rates from 30 to 60 m³/h
- Energy Class A
- Wi-fi control mode 2.4 GHz via APP: local or remote connection
- Integration Voice assistants and Google Home
- Automatic closing damper
- Functions: Comfort - Humidity threshold - Natural recirculation - Night mode
- MASTER function / SLAVE: Possibility to connect in cascade via WIFI up to 4 slaves
- Slaves configurable in synchronous or asynchronous mode.

 **UNITÉ DE VENTILATION AVEC RÉCUPÉRATION DE CHALEUR PONCTUELLE MURALE**

CARACTÉRISTIQUES TECHNIQUES

- Pour l'installation murale
- Épaisseur frontale du mur 35 mm
- Disponible avec des débits de 30 à 60 m³/h
- Classe énergétique A
- Mode de contrôle Wi-fi 2.4 GHz via APP : connexion locale ou à distance
- Intégration Assistants vocaux et Google Home
- Volet de fermeture automatique
- Fonctions : Confort - Seuil d'humidité - Circulation naturelle - Mode nuit
- Fonction MASTER / SLAVE: Possibilité de se connecter en cascade via WIFI jusqu'à 4 esclaves
- Slaves configurable in synchronous or asynchronous mode.

 **DEZENTRALE WÄRMERÜCKGEWINNUNG-EINHEIT ZUR WANDMONTAGE, OHNE FERNBEDIENUNG**

TECHNISCHE EIGENSCHAFTEN

- Zur Wandmontage geeignet
- Frontdicke 35 mm
- Erhältlich mit Durchflussraten von 30 bis 60 m³/h
- Energieeffizienzklasse A
- 2.4 GHz WiFi-Steuerungsmodus per APP: lokale oder Remote-Verbindung
- Integration Sprachassistenten und Google Home
- Automatische Klappe zum Schließen
- Funktionen: Komfort - Feuchtigkeitschwelle - Natürliche Zirkulation - Nachtmodus
- MASTER/SLAVE-Funktion: Kaskadierbarkeit über WIFI bis zu 4 Slaves möglich
- Synchron-oder asynchron modus konfigurierbar

A

PICO
pro



Virtual reality



Remote control supplied



FREE APP AVAILABLE ON



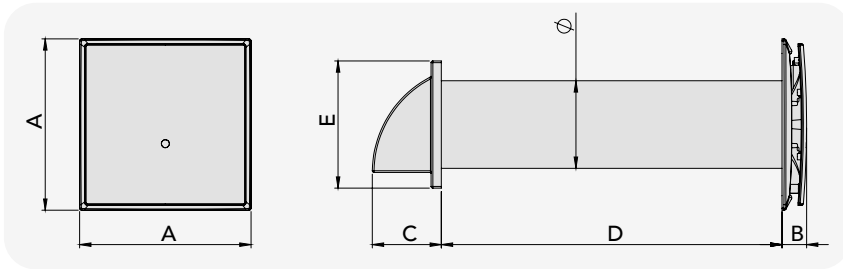

DIMENSIONS AND MODELS	A [mm]	B [mm]	C [mm]	D [mm]	E [mm]	Ø [mm]
PICO PRO 30	250	35	86	500	154	103
PICO PRO 45	250	35	101	500	186	128
PICO PRO 60	250	35	101	500	186	153

PICO PRO 30

TECHNICAL DATA	STANDBY	NIGHT		MIN. 1 SPEED		MIN. 2 SPEED		MIN. 3 SPEED	
		Extraction	Ventilation	Extraction	Ventilation	Extraction	Ventilation	Extraction	Ventilation
MODE	-	Extraction	Ventilation	Extraction	Ventilation	Extraction	Ventilation	Extraction	Ventilation
CONSUMPTION [W]	<1W	1.5 W	1.5 W	2 W	2 W	3 W	3 W	4 W	4 W
AIR FLOW RATE [M ³ /H]	-	6	6	10	10	18	20	26	30
SOUND POWER [DB(A)]	-	18	19	22	23	26	27	29	32
SEC ENERGY CLASS	A								
TYPE	UVR Dual Flow								
TYPE OF HEAT RECOVERY UNIT	Regenerative type HRC3b								
FILTRATION CLASS	G2								

PICO PRO 45

TECHNICAL DATA	STANDBY	NIGHT		MIN. 1 SPEED		MIN. 2 SPEED		MIN. 3 SPEED	
		Extraction	Ventilation	Extraction	Ventilation	Extraction	Ventilation	Extraction	Ventilation
MODE	-	Extraction	Ventilation	Extraction	Ventilation	Extraction	Ventilation	Extraction	Ventilation
CONSUMPTION [W]	<1W	1.5 W	1.5 W	2 W	2 W	3 W	3 W	4.5 W	4.5 W
AIR FLOW RATE [M ³ /H]	-	8	8	21	22	28	32	40	45
SOUND POWER [DB(A)]	-	20	22	24	27	28	30	35	37
SEC ENERGY CLASS	A								
TYPE	UVR Dual Flow								
TYPE OF HEAT RECOVERY UNIT	Regenerative type HRC3b								
FILTRATION CLASS	G2								

PICO PRO 60

TECHNICAL DATA	STANDBY	NIGHT		MIN. 1 SPEED		MIN. 2 SPEED		MIN. 3 SPEED	
		Extraction	Ventilation	Extraction	Ventilation	Extraction	Ventilation	Extraction	Ventilation
MODE	-	Extraction	Ventilation	Extraction	Ventilation	Extraction	Ventilation	Extraction	Ventilation
CONSUMPTION [W]	<1W	1.7 W	1.7 W	3 W	3 W	4.5 W	4.5 W	7 W	7 W
AIR FLOW RATE [M ³ /H]	-	11	11	32	30	46	40	65	60
SOUND POWER [DB(A)]	-	24	28	30	32	35	38	40	41
SEC ENERGY CLASS	A								
TYPE	UVR Dual Flow								
TYPE OF HEAT RECOVERY UNIT	Regenerative type HRC3b								
FILTRATION CLASS	G2								

CODE	DESCRIPTION	U.M.	U.M.			Datasheet
			Pieces per box	Box	Pallet	
ACD100056	HEAT RECOVERY UNIT - PICO PRO 30	PCS	1	1	12	
ACD100057	HEAT RECOVERY UNIT - PICO PRO 45	PCS	1	1	12	
ACD100058	HEAT RECOVERY UNIT - PICO PRO 60	PCS	1	1	12	



VENTILATION UNITS WITH WALL-MOUNTED PUNTUAL HEAT RECOVERY

TECHNICAL SPECIFICATIONS

- For wall installation
- Front wall thickness 35 mm
- Available with flow rates from 30 to 60 m³/h
- Energy Class A
- Wi-fi control mode 2.4 GHz via APP: local or remote connection
- Integration Voice assistants and Google Home
- Automatic closing damper
- Functions: Comfort - CO2 threshold - Humidity threshold - Natural recirculation - Free Cooling - Free Heating - Night mode
- MASTER function / SLAVE: Possibility to connect in cascade via WIFI up to 4 slaves
- Slaves configurable in synchronous or asynchronous mode.

UNITÉ DE VENTILATION AVEC RÉCUPÉRATION DE CHALEUR PONCTUELLE MURALE

CARACTÉRISTIQUES TECHNIQUES

- Pour l'installation murale
- Épaisseur frontale du mur 35 mm
- Disponible avec des débits de 30 à 60 m³/h
- Classe énergétique A
- Mode de contrôle Wi-fi 2.4 GHz via APP : connexion locale ou à distance
- Intégration Assistants vocaux et Google Home
- Volet de fermeture automatique
- Fonctions : Confort - Seuil CO2 - Seuil d'humidité - Recirculation naturelle - Free Cooling - Free Heating - Mode Nuit
- Fonction MASTER / SLAVE: Possibilité de se connecter en cascade via WIFI jusqu'à 4 esclaves
- Slaves configurable in synchronous or asynchronous mode.

DEZENTRALE WÄRMERÜCKGEWINNUNG-EINHEIT ZUR WANDMONTAGE, OHNE FERNBEDIENUNG

TECHNISCHE EIGENSCHAFTEN

- Zur Wandmontage geeignet
- Frontdicke 35 mm
- Erhältlich mit Durchflussraten von 30 bis 60 m³/h
- Energieeffizienzklasse A
- 2.4 GHz WiFi-Steuerungsmodus per APP: lokale oder Remote-Verbindung
- Integration Sprachassistenten und Google Home
- Automatische Klappe zum Schließen
- Funktionen: Komfort - CO2-Schwelle - Feuchtigkeitsschwelle - Natürliche Rückführung - Free Cooling - Free Heating - Night-Modus
- MASTER/SLAVE-Funktion: Kaskadierbarkeit über WIFI bis zu 4 Slaves möglich
- Synchron-oder asynchron modus konfigurierbar

A

PICO
pro+



Virtual reality



Remote control
supplied



FREE APP AVAILABLE ON



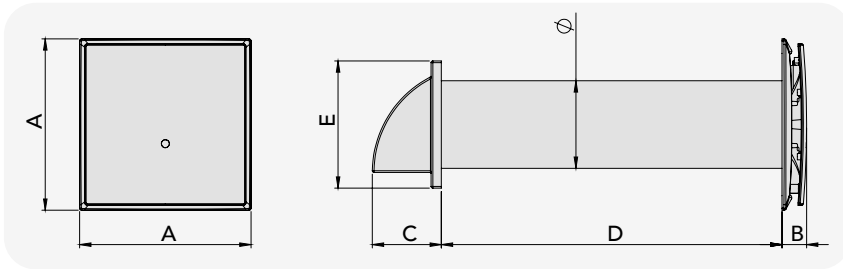

DIMENSIONS AND MODELS	A [mm]	B [mm]	C [mm]	D [mm]	E [mm]	Ø [mm]
PICO PRO + 30	250	35	86	500	154	103
PICO PRO + 45	250	35	101	500	186	128
PICO PRO + 60	250	35	101	500	186	153

PICO PRO+ 30

TECHNICAL DATA	STANDBY	NIGHT		MIN. 1 SPEED		MIN. 2 SPEED		MIN. 3 SPEED	
		Extraction	Ventilation	Extraction	Ventilation	Extraction	Ventilation	Extraction	Ventilation
MODE	-	Extraction	Ventilation	Extraction	Ventilation	Extraction	Ventilation	Extraction	Ventilation
CONSUMPTION [W]	<1W	1.5 W	1.5 W	2 W	2 W	3 W	3 W	4 W	4 W
AIR FLOW RATE [M ³ /H]	-	6	6	10	10	18	20	26	30
SOUND POWER [DB(A)]	-	18	19	22	23	26	27	29	32
SEC ENERGY CLASS	A								
TYPE	UVR Dual Flow								
TYPE OF HEAT RECOVERY UNIT	Regenerative type HRC3b								
FILTRATION CLASS	G2								

PICO PRO+ 45

TECHNICAL DATA	STANDBY	NIGHT		MIN. 1 SPEED		MIN. 2 SPEED		MIN. 3 SPEED	
		Extraction	Ventilation	Extraction	Ventilation	Extraction	Ventilation	Extraction	Ventilation
MODE	-	Extraction	Ventilation	Extraction	Ventilation	Extraction	Ventilation	Extraction	Ventilation
CONSUMPTION [W]	<1W	1.5 W	1.5 W	2 W	2 W	3 W	3 W	4.5 W	4.5 W
AIR FLOW RATE [M ³ /H]	-	8	8	21	22	28	32	40	45
SOUND POWER [DB(A)]	-	20	22	24	27	28	30	35	37
SEC ENERGY CLASS	A								
TYPE	UVR Dual Flow								
TYPE OF HEAT RECOVERY UNIT	Regenerative type HRC3b								
FILTRATION CLASS	G2								

PICO PRO+ 60

TECHNICAL DATA	STANDBY	NIGHT		MIN. 1 SPEED		MIN. 2 SPEED		MIN. 3 SPEED	
		Extraction	Ventilation	Extraction	Ventilation	Extraction	Ventilation	Extraction	Ventilation
MODE	-	Extraction	Ventilation	Extraction	Ventilation	Extraction	Ventilation	Extraction	Ventilation
CONSUMPTION [W]	<1W	1.7 W	1.7 W	3 W	3 W	4.5 W	4.5 W	7 W	7 W
AIR FLOW RATE [M ³ /H]	-	11	11	32	30	46	40	65	60
SOUND POWER [DB(A)]	-	24	28	30	32	35	38	40	41
SEC ENERGY CLASS	A								
TYPE	UVR Dual Flow								
TYPE OF HEAT RECOVERY UNIT	Regenerative type HRC3b								
FILTRATION CLASS	G2								

CODE	DESCRIPTION	U.M.	U.M.		
			Pieces per box	Box	Pallet
ACD100052	HEAT RECOVERY UNIT - PICO PRO + 30	PCS	1	1	12
ACD100053	HEAT RECOVERY UNIT - PICO PRO + 45	PCS	1	1	12
ACD100054	HEAT RECOVERY UNIT - PICO PRO + 60	PCS	1	1	12

[Datasheet](#)

TRY THE NEW SOFTWARE FOR SIZING YOUR MVHR SYSTEM

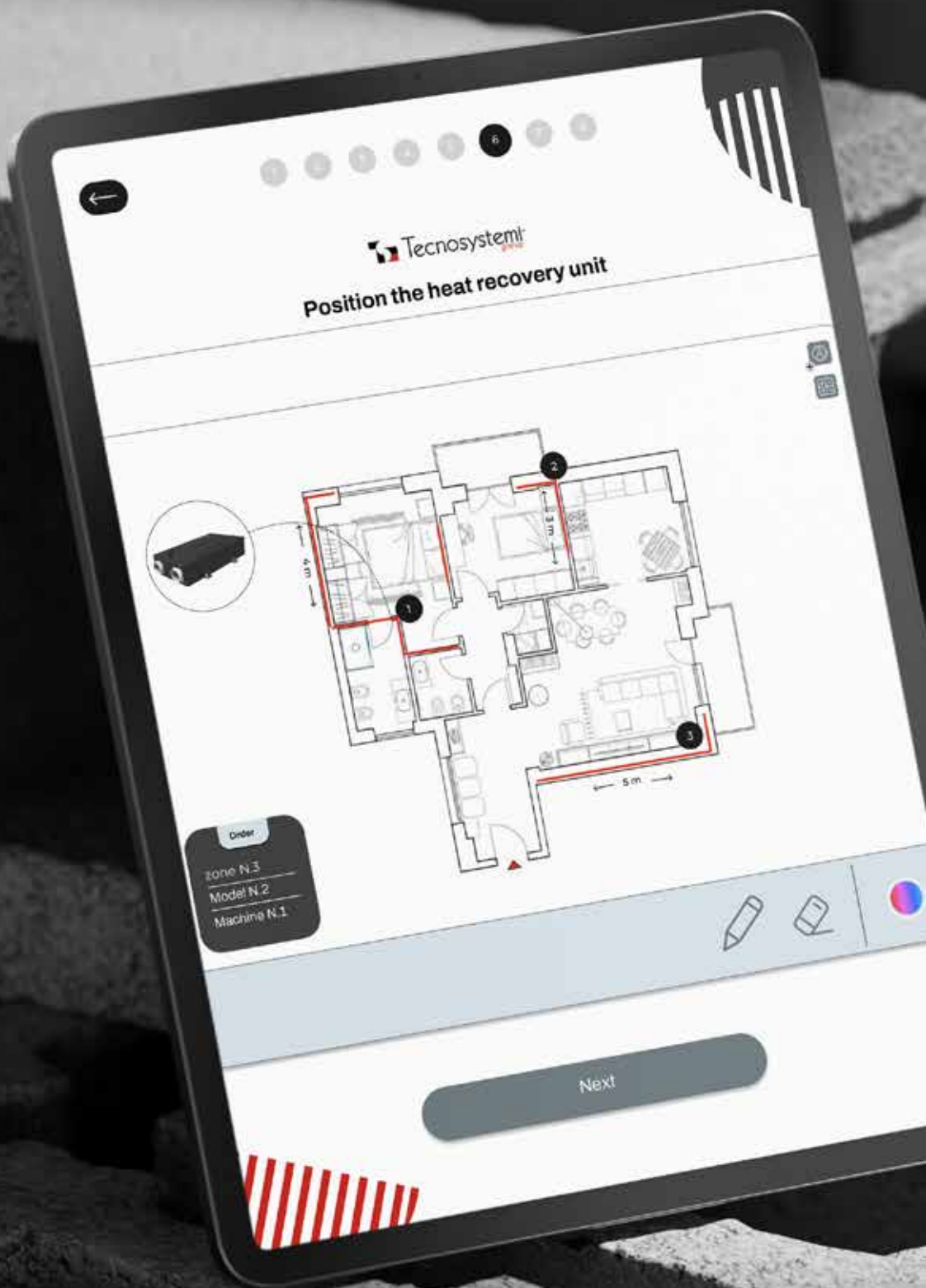

SCAN THE
QR CODE

Available from February 2025

REMOTE CONTROLLER WITH NEW FUNCTIONS

RESET FILTER MAINTENANCE

Press and hold for 3 seconds

Fan OFF

RECOVERY UNIT

The recovery fans operate simultaneously (in and out) with three adjustable speeds.

EXTRACTION

The device works in internal air extraction mode only. Option to regulate the three speeds.

AUTO 3 - SUMMER COMFORT MODE

The system is on standby. When the external temperature is lower than the internal one, the heat recovery unit goes onto high-speed output mode. When the temperature recovers its value the unit goes back onto stand-by.

AUTO 4 WINTER COMFORT MODE

The system is on stand-by. When the external temperature is higher than the internal one, the heat recovery unit goes onto high-speed output mode. When the temperature recovers its value the unit goes back onto stand-by.

Fan ON and Humidity value setting

Speed Change



Maximum speed

(Humidity value 60%)

Average speed

(Humidity value 50%)

Minimum speed

(Humidity value 40%)

Change mode

AUTO 2

The device is in stand-by. When the air in the room exceeds the threshold of settable humidity at 40%, 50% or 60%, the device switches to extraction only mode until the humidity level falls within the set values.

AUTO 1

The device is in stand-by. When the air in the room exceeds the threshold of settable humidity at 40%, 50% or 60%, the device switches to recovery only mode until the humidity level falls within the set values.

AUTO 6

The system is on stand-by. When the CO₂ threshold of 800 ppmv is exceeded, the heat recovery unit goes onto high-speed recovery mode. When the CO₂ value recovers the unit goes back onto stand-by.

AUTO 5

The system is on stand-by. When the CO₂ threshold of 800 ppmv is exceeded, the heat recovery unit goes onto high-speed output. When the CO₂ value recovers the unit goes back onto stand-by.

AERATION

The device works in aeration mode only, taking in external air and introducing it into the room. Option to regulate the three speeds.

OPERATING MODES



REGENERATOR

The device works for 70 seconds in extraction mode and 70 seconds in aeration mode, with the option to regulate the three speeds.

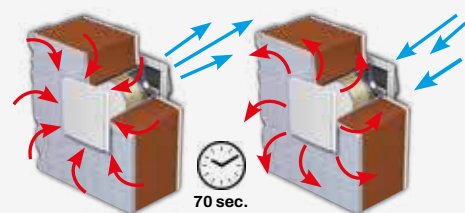

EXTRACTION

The device works in internal air extraction mode only, with the option to regulate the three speeds.

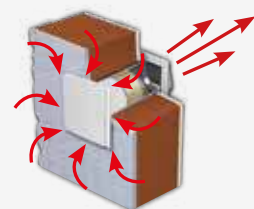

AERATION

The device works in aeration mode only, taking in air from outside and introducing it into the room. Option to regulate the three speeds provided.

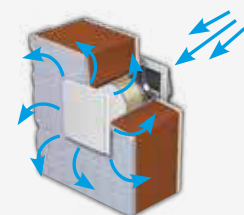

AUTO 1

The device is on stand-by.

When the air in the room exceeds the humidity level, that can be set at 40%, 50% or 60%, the device goes onto recovery mode until the humidity recovers according to the set value.

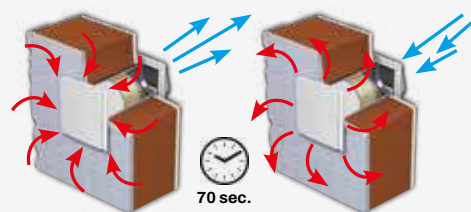

AUTO 1

The device is on stand-by. when the air in the room exceeds the humidity level, that can be set at 40%, 50% or 60%, the device goes onto extraction only mode until the humidity level recovers according to the set value.

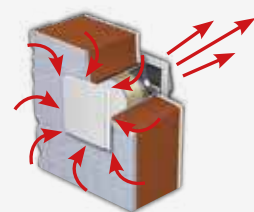

DESCRIPTION	REGENERATOR	EXTRACTION
"AIR PUR 3 PLUS WI" BUILT-IN CROSS-FLOW STATIC HEAT RECOVERY UNIT MODEL 160	•	•
"AIR PUR 3 PLUS WI" BUILT-IN CROSS-FLOW STATIC HEAT RECOVERY UNIT MODEL 230	•	•
"AIR PUR 3 PLUS WI" BUILT-IN CROSS-FLOW STATIC HEAT RECOVERY UNIT MODEL 300	•	•
"COMFORT - AIR PUR 3 PLUS WI-C" BUILT-IN CROSS-FLOW STATIC HEAT RECOVERY UNIT MODEL 160	•	•
"COMFORT - AIR PUR 3 PLUS WI-C" BUILT-IN CROSS-FLOW STATIC HEAT RECOVERY UNIT MODEL 230	•	•
"COMFORT - AIR PUR 3 PLUS WI-C" BUILT-IN CROSS-FLOW STATIC HEAT RECOVERY UNIT MODEL 300	•	•
"AIR PUR 3 PLUS WI" WALL MOUNTED CROSS-FLOW STATIC HEAT RECOVERY UNIT MODEL 160	•	•
"AIR PUR 3 PLUS WI" WALL MOUNTED CROSS-FLOW STATIC HEAT RECOVERY UNIT MODEL 230	•	•
"AIR PUR 3 PLUS WI" WALL MOUNTED CROSS-FLOW STATIC HEAT RECOVERY UNIT MODEL 300	•	•
"COMFORT - AIR PUR 3 PLUS WI-C" WALL MOUNTED CROSS-FLOW STATIC HEAT RECOVERY UNIT MODEL 160	•	•
"COMFORT - AIR PUR 3 PLUS WI-C" WALL MOUNTED CROSS-FLOW STATIC HEAT RECOVERY UNIT MODEL 230	•	•
"COMFORT - AIR PUR 3 PLUS WI-C" WALL MOUNTED CROSS-FLOW STATIC HEAT RECOVERY UNIT MODEL 300	•	•



AUTO3 - SUMMER COMFORT

The system is on stand-by. If the external temperature is lower than the internal one, the heat recovery unit goes onto high-speed intake. When the temperature recovers its value the unit goes back onto standby.

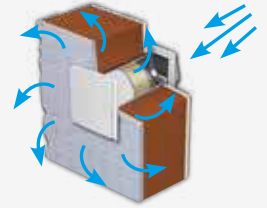

AUTO4 - WINTER COMFORT

The system is on stand-by. If the external temperature is higher than the internal one, the heat recovery unit goes onto high-speed intake. When the temperature recovers its value the unit goes back onto standby.

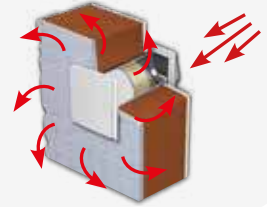

AUTO5

The system is on stand-by. When the CO₂ threshold is exceeded the heat recovery unit goes onto high-speed recovery. When the CO₂ value recovers the unit goes back onto standby.

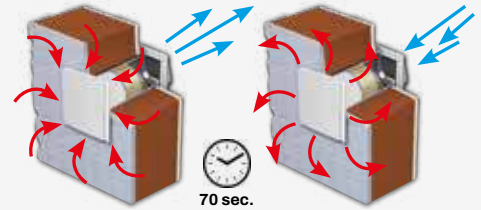

AUTO6

The system is on stand-by. When the CO₂ threshold is exceeded the heat recovery unit goes onto high-speed output. When the CO₂ value recovers the unit goes back onto standby.

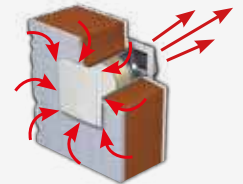

FILTER MAINTENANCE

The red flashing led indicates the need to perform the maintenance of filters and the heat exchanger.



SETTING THE HUMIDITY VALUE

When the blue led turns on, it indicates the access to the humidity value settings mode. it is possible to set the humidity threshold to three different values 40%, 50% o 60%

AERATION	SETTING HUMIDITY VALUE	WI-FI	AUTO 1	AUTO 2	AUTO 3	AUTO 4	AUTO 5	AUTO 6	INSTRUCTIONS FILTER MAINTENANCE
•	•	•	•	•					•
•	•	•	•	•					•
•	•	•	•	•					•
•	•	•	•	•	•	•			•
•	•	•	•	•	•	•			•
•	•	•	•	•	•	•			•
•	•	•	•	•					•
•	•	•	•	•					•
•	•	•	•	•	•	•			•
•	•	•	•	•	•	•			•
•	•	•	•	•	•	•			•

AIR PUR 3 PLUS WI

MADE IN ITALY



AirPur3^{PLUS}
wi

 **STATIC HEAT RECOVERY**
BUILT-IN CROSS-FLOW AND
WALL-MOUNTED 160 - 230 - 300

 **RÉCUPÉRATEUR DE**
CHALEUR STATIQUE À
FLUX CROISÉS STATIQUE
ENCASTRÉ ET MURAL
160 - 230 - 300

 **ZENTRALE QUERSTROM**
WÄRMERÜCKGEWIN-
NUNGSEINHEIT ZUM EINBAU
ODER AUFHÄNGEN 160-230-
300



Built-in model



Wall mounted model

WI-FI Control mode (Off-Line)

See operation modes at page 28



Heat Recovery System

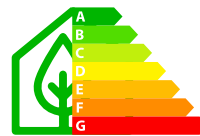

EFFICIENCY 75%



Cross flow

Accessories



Remote control supplied

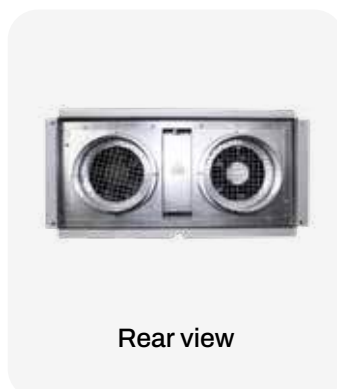

Rear view



External aesthetic grid

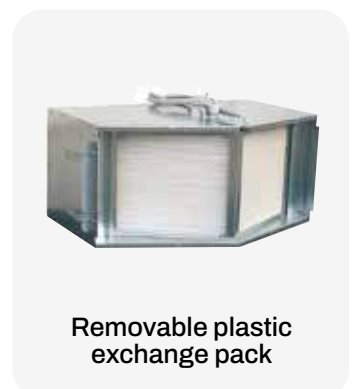

Removable plastic exchange pack

AIR PUR 3 PLUS WI

Built-in model version



BUILT-IN STATIC CROSS-FLOW HEAT RECOVERY UNIT 160 - 230 - 300

RÉCUPÉRATEUR DE CHALEUR À FLUX CROISÉS STATIQUE ENCASTRÉ 160 - 230 - 300

EINGEBAUTE ZENTRALE QUERSTROMWÄRMERÜCKGEWINNUNGSEINHEIT 160 - 230 - 300

MODEL	160 WI	230 WI	300 WI
POWER SUPPLY [V]	230	230	230
FREQUENCY [Hz]	50	50	50
MAX POWER [W]	30	35	70
PROTECTION RATING	IP20		
% EXCHANGE EFFICIENCY	I°: 76%	I°: 72%	I°: 67%
	II°: 74%	II°: 70%	II°: 64%
	III°: 73%	III°: 68%	III°: 60%
AIR FLOW RATE [m³/h]	I°: 70	I°: 92	I°: 150
	II°: 120	II°: 166	II°: 264
	III°: 161	III°: 230	III°: 300
SOUND LEVEL [dB(A)]	I°: 36	I°: 36	I°: 40
	II°: 44	II°: 45	II°: 51
	III°: 48	III°: 49	III°: 53
WEIGHT [kg]	18	19	19
WALL HOLE [mm]	230 x 490	230 x 490	230 x 490

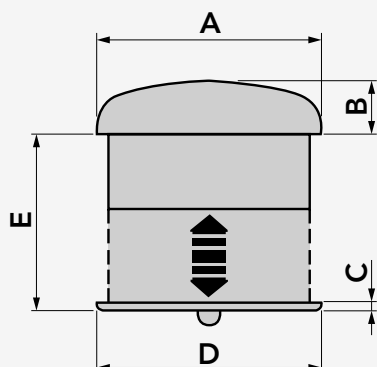
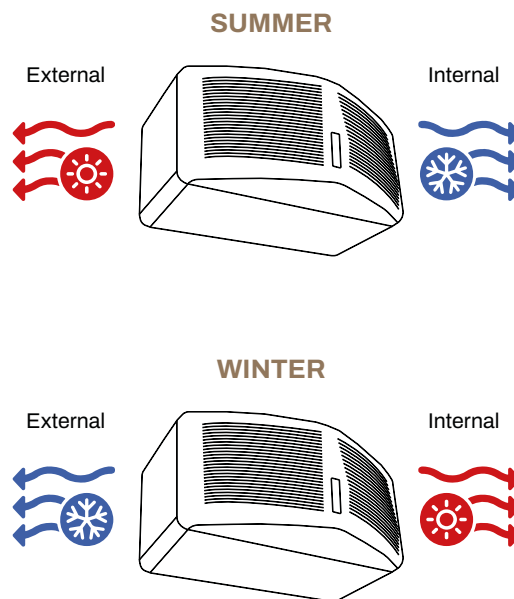

MODELS 160 / 230 / 300 WI	
DIMENSIONS	[mm]
A	532
B	125
C	19
D	536
E	220 ÷ 400
INTERNAL GRILLE HEIGHT	265
EXTERNAL GRILLE HEIGHT	292
RECOVERY UNIT BOX	220

CODE	DESCRIPTION	U.M.	Pieces per box
ACD200005	"AIR PUR 3 PLUS WI" BUILT-IN CROSS-FLOW STATIC HEAT RECOVERY UNIT, MOD. 160	PCS	1
ACD200006	"AIR PUR 3 PLUS WI" BUILT-IN CROSS-FLOW STATIC HEAT RECOVERY UNIT, MOD. 230	PCS	1
ACD200007	"AIR PUR 3 PLUS WI" BUILT-IN CROSS-FLOW STATIC HEAT RECOVERY UNIT, MOD. 300	PCS	1

[Datasheet](#)



AIR PUR 3 PLUS WI

Wall-mounted model version



WALL-MOUNTED STATIC CROSS-FLOW HEAT RECOVERY UNIT 160 - 230 - 300

RÉCUPÉRATEUR DE CHALEUR À FLUX CROISÉS MURAL 160 - 230 - 300

AUFHÄNGEN ZENTRALE QUERSTROMWÄRMERÜCKGEWINNUNGSEINHEIT 160 - 230 - 300

MODEL	160 WI	230 WI	300 WI
POWER SUPPLY [V]	230	230	230
FREQUENCY [Hz]	50	50	50
MAX POWER [W]	30	35	70
PROTECTION RATING	IP20		
% EXCHANGE EFFICIENCY	I°: 76%	I°: 72%	I°: 67%
	II°: 74%	II°: 70%	II°: 64%
	III°: 73%	III°: 68%	III°: 60%
AIR FLOW RATE [m³/h]	I°: 70	I°: 92	I°: 150
	II°: 120	II°: 166	II°: 264
	III°: 161	III°: 230	III°: 300
SOUND LEVEL [dB(A)]	I°: 36	I°: 36	I°: 40
	II°: 44	II°: 45	II°: 51
	III°: 48	III°: 49	III°: 53
WEIGHT [kg]	21	22	22
WALL HOLE [mm]	Ø170	Ø170	Ø170

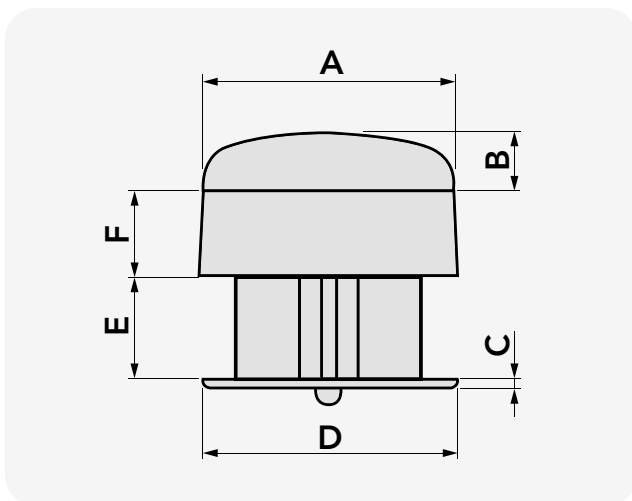
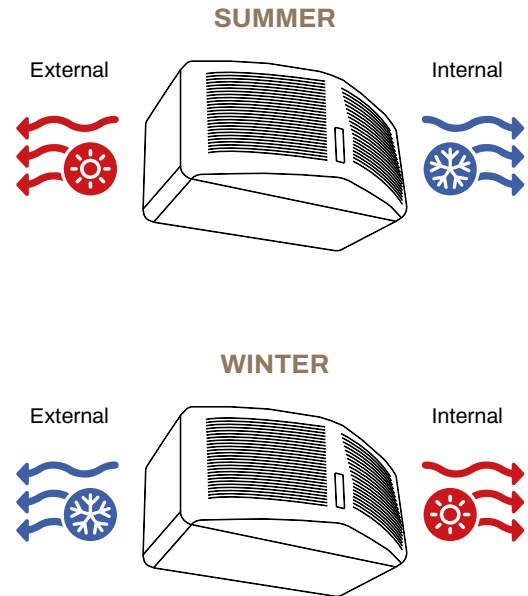

MODELS 160 / 230 / 300 WI	
DIMENSIONS	[mm]
A	532
B	125
C	19
D	536
E	400
F	220
INTERNAL GRILLE HEIGHT	265
EXTERNAL GRILLE HEIGHT	292
RECOVERY UNIT BOX	289

CODE	DESCRIPTION	U.M.	Pieces per box
ACD200014	VR180 - VERY HIGH EFFICIENCY DUCTABLE STATIC RECOVERY UNIT WITH AUTOMATIC BY-PASS	PCS	1
ACD200015	"AIR PUR 3 PLUS WI" WALL MOUNTED CROSS-FLOW STATIC HEAT RECOVERY UNIT, MOD. 230	PCS	1
ACD200016	"AIR PUR 3 PLUS WI" WALL MOUNTED CROSS-FLOW STATIC HEAT RECOVERY UNIT, MOD. 300	PCS	1



AIR PUR 3 PLUS WI-C

MADE IN ITALY



AirPur3^{PLUS}
wi-c

**STATIC HEAT RECOVERY
BUILT-IN CROSS-FLOW AND
WALL-MOUNTED 160 - 230 - 300**

**RÉCUPÉRATEUR
DE CHALEUR STATIQUE
À FLUX CROISÉS STATIQUE
ENCASTRÉ ET MURAL 160 -
230 - 300**

**ZENTRALE QUERSTROM
WÄRMERÜCKGEWIN-
NUNGSEINHEIT ZUM EINBAU
ODER AUFHÄNGEN 160-230-
300**



Built-in model



Wall mounted model

WI-FI Control mode (Off-Line)

See operation modes at page 28



Heat Recovery System

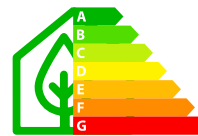

EFFICIENCY 75%



Cross flow

Accessories



Remote control supplied

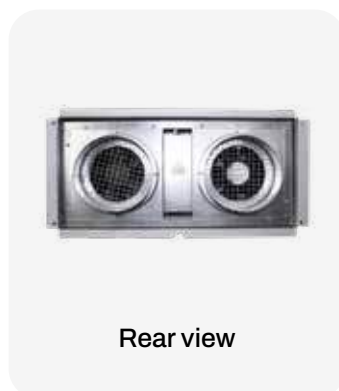

Rear view



External aesthetic grid



Removable plastic exchange pack

AIR PUR 3 PLUS WI-C

Built-in model version



AirPur3^{PLUS}
wi-c

BUILT-IN STATIC CROSS-FLOW HEAT RECOVERY UNIT 160 - 230 - 300

RÉCUPÉRATEUR DE CHALEUR À FLUX CROISÉS STATIQUE ENCASTRÉ 160 - 230 - 300

EINGEBAUTE ZENTRALE QUERSTROM WÄRMERÜCKGEWINNUNGSEINHEIT 160 - 230 - 300

MODEL	160 WI-C	230 WI-C	300 WI-C
POWER SUPPLY [V]	230	230	230
FREQUENCY [Hz]	50	50	50
MAX POWER [W]	30	35	70
PROTECTION RATING	IP20		
% EXCHANGE EFFICIENCY	I°: 76%	I°: 72%	I°: 67%
	II°: 74%	II°: 70%	II°: 64%
	III°: 73%	III°: 68%	III°: 60%
AIR FLOW RATE [m³/h]	I°: 70	I°: 92	I°: 150
	II°: 120	II°: 166	II°: 264
	III°: 161	III°: 230	III°: 300
SOUND LEVEL [dB(A)]	I°: 36	I°: 36	I°: 40
	II°: 44	II°: 45	II°: 51
	III°: 48	III°: 49	III°: 53
WEIGHT [kg]	18	19	19
WALL HOLE [mm]	230 x 490	230 x 490	230 x 490

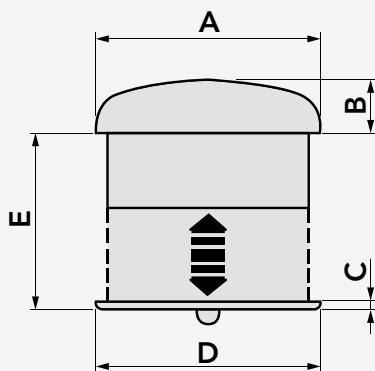
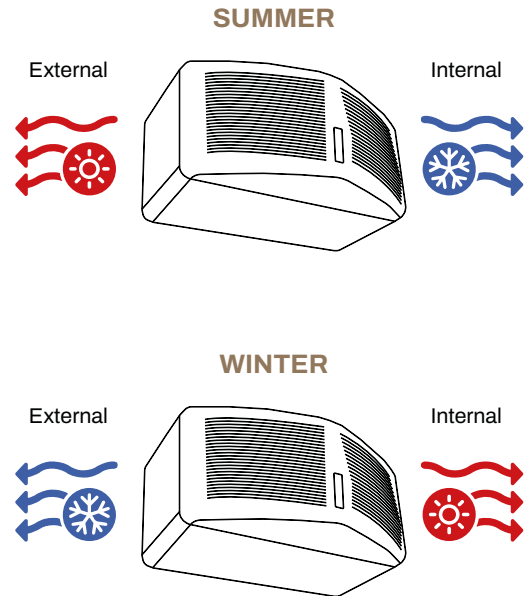

MODELS 160 / 230 / 300 WI-C	
DIMENSIONS	[mm]
A	532
B	125
C	19
D	536
E	220 ÷ 400
INTERNAL GRILLE HEIGHT	265
EXTERNAL GRILLE HEIGHT	292
RECOVERY UNIT BOX	220

CODE	DESCRIPTION	U.M.	Pieces per box
ACD200008	"COMFORT-AIR PUR 3 PLUS WI-C" BUILT-IN STATIC HEAT RECOVERY UNIT, MOD.160	PCS	1
ACD200009	"COMFORT-AIR PUR 3 PLUS WI-C" BUILT-IN STATIC HEAT RECOVERY UNIT, MOD.230	PCS	1
ACD200010	"COMFORT-AIR PUR 3 PLUS WI-C" BUILT-IN STATIC HEAT RECOVERY UNIT, MOD.300	PCS	1



AIR PUR 3 PLUS WI-C

Wall-mounted model version



AirPur3^{PLUS}
wi-c

WALL-MOUNTED STATIC CROSS-FLOW HEAT RECOVERY UNIT 160 - 230 - 300

RÉCUPÉRATEUR DE CHALEUR À FLUX CROISÉS MURAL 160 - 230 - 300

AUFHÄNGEN ZENTRALE QUERSTROM WÄRMERÜCKGEWINNUNGSEINHEIT 160 - 230 - 300

MODEL	160 WI-C	230 WI-C	300 WI-C
POWER SUPPLY [V]	230	230	230
FREQUENCY [Hz]	50	50	50
MAX POWER [W]	30	35	70
PROTECTION RATING	IP20		
% EXCHANGE EFFICIENCY	I°: 76%	I°: 72%	I°: 67%
	II°: 74%	II°: 70%	II°: 64%
	III°: 73%	III°: 68%	III°: 60%
AIR FLOW RATE [m³/h]	I°: 70	I°: 92	I°: 150
	II°: 120	II°: 166	II°: 264
	III°: 161	III°: 230	III°: 300
SOUND LEVEL [dB(A)]	I°: 36	I°: 36	I°: 40
	II°: 44	II°: 45	II°: 51
	III°: 48	III°: 49	III°: 53
WEIGHT [kg]	21	22	22
WALL HOLE [mm]	Ø170	Ø170	Ø170

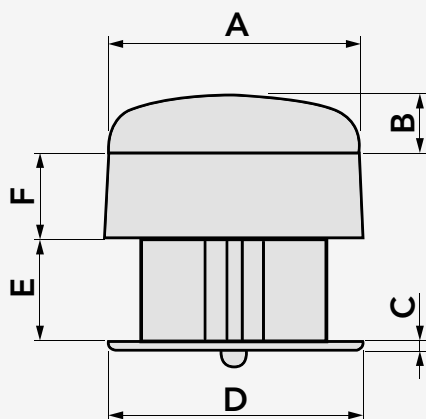
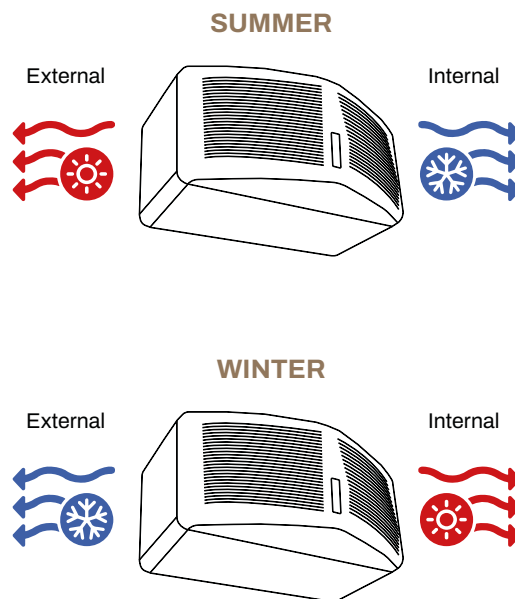

MODELS 160 / 230 / 300 WI-C	
DIMENSIONS	[mm]
A	532
B	125
C	19
D	536
E	400
F	220
INTERNAL GRILLE HEIGHT	265
EXTERNAL GRILLE HEIGHT	292
RECOVERY UNIT BOX	289

CODE	DESCRIPTION	U.M.	Pieces per box
ACD200017	"COMFORT-AIR PUR 3 PLUS WI-C WALL MOUNTED STATIC HEAT RECOVERY UNIT, MOD.160	PCS	1
ACD200018	"COMFORT-AIR PUR 3 PLUS WI-C" WALL MOUNTED STATIC HEAT RECOVERY UNIT, MOD. 230	PCS	1
ACD200019	"COMFORT-AIR PUR 3 PLUS WI-C" WALL MOUNTED STATIC HEAT RECOVERY UNIT, MOD. 300	PCS	1

Datasheet



EXAMPLE OF WALL INSTALLATION AIR PUR 3 PLUS WI / WI-C

AirPur3^{PLUS}
wi

AirPur3^{PLUS}
wi-C

BUILT-IN MODEL

Standard equipment included with built-in models:

1. Front grille and control panel
2. Telescopic connecting plenum for the securing of the external grille
3. External grille
4. Removable, washable air inlet/outlet filter
5. ON/OFF 3 speed remote control device
6. 3 speed motor
7. Arrangement for connection of rigid/flexible condensate discharge pipe
8. Recyclable plastic filling material
9. Insulated shells guaranteeing maximum

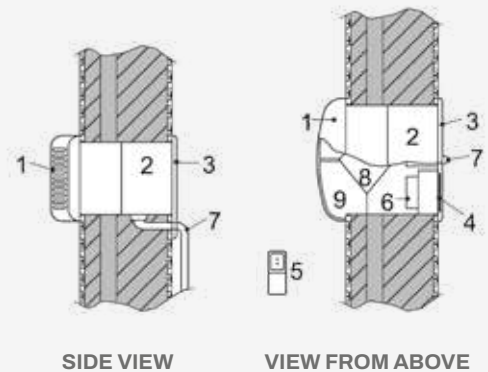

WALL-MOUNTED MODEL

Standard equipment included with wall-mounted models:

1. Front grille and control panel
2. Connecting pipes to external grilles
3. External grille
4. Removable, washable air inlet/outlet filter
5. ON/OFF 3 speed remote control device
6. 3 speed motor
7. Arrangement for connection of rigid/flexible condensate discharge pipe
8. Recyclable plastic filling material
9. Insulated shells guaranteeing maximum

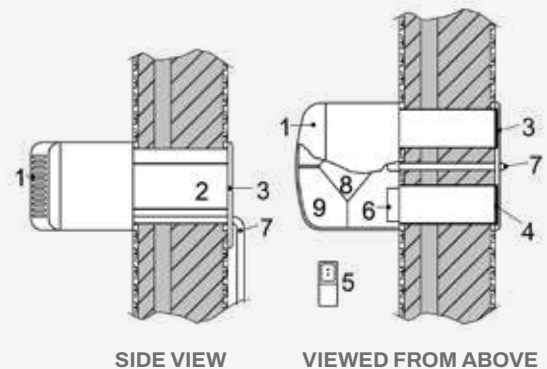

SILENCE AIR PLUS



UNITED KINGDOM
WALL-MOUNTED RESIDENTIAL HEAT RECOVERY UNIT, CAN BE INTEGRATED WITH BMS SYSTEMS

TECHNICAL SPECIFICATIONS

- Ideal for wall mounting
- Hepa filtering efficiency 99%
- RS485 communication port with modbus protocol
- Insulating material that prevents condensation
- Indoor and outdoor air filtration
- High-efficiency heat and humidity recovery
- Low noise
- Brushless EC motors
- Air quality index (AQI) monitoring

FRANCE
UNITÉ DE RÉCUPÉRATION DE CHALEUR RÉSIDENTIELLE MURALE, INTÉGRABLE AVEC LES SYSTÈMES BMS

CARACTÉRISTIQUES TECHNIQUES

- Idéale pour l'installation murale
- Efficacité filtrage hepa 99%
- Porte de communication RS485 avec protocole modbus
- Matériau isolant qui empêche la formation de condensation
- Filtration de l'air interne et externe
- Récupération de chaleur et d'humidité à haut rendement
- Faible bruit
- Moteurs Brushless EC
- Suivi de l'indice de qualité de l'air (AQI)

GERMANY
WANDMONTIERTE WÄRMERÜCKGEWINNUNGSEINHEIT FÜR WOHN- GEBÄUDE, INTEGRIERBAR MIT BMS SYSTEMEN

TECHNISCHE EIGENSCHAFTEN

- Bestens für die wandmontage geeignet
- 99% Hepa-filterwirkung
- Kommunikationsanschluss RS485 mit Modbus-protokoll
- Isoliermaterial, das Kondensationsbildung verhindert
- Innen- und Außenluftfiltration
- Hocheffiziente Wärme- und Feuchtigkeitsrückgewinnung
- Geräuscharm
- Brushless EC Motoren
- Überwachung des Luftqualitätsindex (AQI)



SILENCE AIR PLUS is a heat recovery ventilation unit with a built-in air purification function.

Suitable for wall-mounted installation, it allows air exchange with heat and humidity recovery thanks to the cross-flow enthalpy heat exchanger.

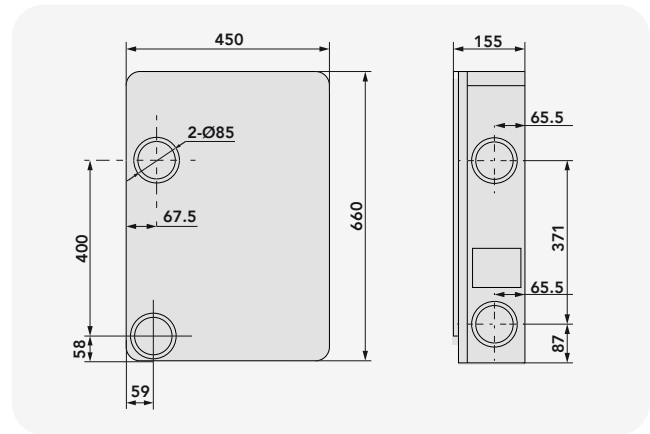

Remote control via App for Smartphone, Tablet and Smart Watch

Thanks to the Smart Life App, your Silence Air Plus can be conveniently managed with your mobile device.

Using the App, you can:

- Change and set the speed
- Check the cleanliness of the filter
- Set a weekly program
- Set a timer
- Control a group of interconnected Silence Air Bacs heat recovery units

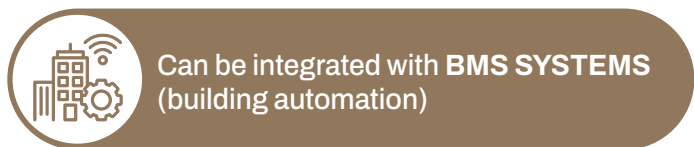

Can be integrated with **BMS SYSTEMS** (building automation)



TECHNICAL DATA	
POWER SUPPLY	230V, 50Hz, single-phase
MAXIMUM POWER CONSUMPTION	44 W
INSULATION CLASS	Class I
IP GRADE	IP X2
MOTORS	Brushless EC
DRIVE	8 speeds
MAXIMUM FLOW RATE	150 m ³ /h
EXCHANGER TYPE	Cross-flow enthalpy
THERMAL EFFICIENCY OF HEAT EXCHANGER	0.82
ENTHALPY EFFICIENCY (HEATING)	0.58
ENTHALPY EFFICIENCY (COOLING)	0.52
AIR TEMPERATURE	-15°C +40 °C
BODY MATERIAL	ABS
OPERATING MODE	Manual
	Automatic
	Timer
	Sleep (silent mode)
	Purification
PURIFIER FUNCTION FILTER	HEPA 99%
ROOM AREA	10 - 50 m ²
AIR QUALITY DISPLAY	Temperature, CO ₂ , relative humidity
CONTROL	Touch-screen display
	Remote control
	Wi-Fi
	BMS
BMS CONNECTION	RS485 protocol Modbus
DIMENSIONS	660 x 450 x 155 mm
WEIGHT	10 kg

Performance at different speeds*

Speed	Air flow capacity in ventilation [m ³ /h]	Electric power [W]	Current [A]	Sound pressure at 1.5 m [dB(A)]
1	50	12.6	0.16	22.6
2	64	16.9	0.18	25.1
3	78	18.1	0.19	27.7
4	92	22.9	0.21	29.7
5	106	25.2	0.24	31.7
6	120	29.2	0.27	33.1
7	134	34.2	0.31	35.1
8	150	43.8	0.37	37.9

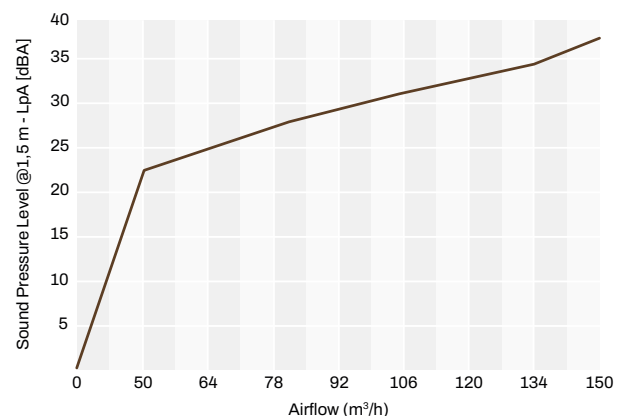

*Laboratory values

Ecodesign performance data

BRAND	Tecnosystemi	
MODEL	ACC300009	
SPECIFIC ENERGY CONSUMPTION (SEC, KWH/M ² /A) AND SEC CLASS	Cold climate	-79,28 (A+)
	Average climate	-40,95 (A)
	Warm climate	-16,36 (E)
TYPE	UVB, UVR - Bidirectional, Residential Ventilation Unit	
DRIVE TYPE	variable speed	
TYPE OF HEAT RECOVERY UNIT	Recovery	
THERMAL EFFICIENCY OF HEAT RECOVERY (%)	82	
MAXIMUM FLOW RATE (M ³ /H)	150	
ELECTRICAL POWER INPUT AT MAXIMUM FLOW RATE (W)	44	
SOUND POWER LEVEL (LWA)	37.9	
REFERENCE FLOW RATE (M ³ /S)	0.0417	
REFERENCE PRESSURE DIFFERENCE (PA)	0	
SPI (W/M ³ /H)	0.292	
CONTROL FACTOR	Local environmental control	
MAXIMUM INTERNAL LEAKAGE RATE (%)	3.5	
MAXIMUM EXTERNAL LEAKAGE RATE (%)	5	
MIXING RATE (%)	20	
AIR FLOW SENSITIVITY TO PRESSURE VARIATIONS +20 PA AND -20 PA	27	
INDOOR/OUTDOOR AIR TIGHTNESS (M ³ /H)	7	
WEBSITE WITH INSTRUCTIONS FOR DISASSEMBLY	www.tecnosystemi.com	
ANNUAL ELECTRICITY CONSUMPTION (AEC) (KWH ELECTRICITY)	Cold climate	7,54
	Average climate	2,16
	Warm climate	1,72
ANNUAL HEATING SAVED (AHS) (KWH PRIMARY ELECTRICITY)	Cold climate	89,4
	Average climate	45,7
	Warm climate	20,66

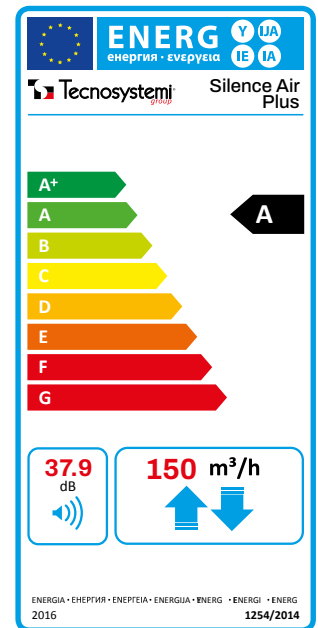

Datasheet



CODE	DESCRIPTION	U.M.	Pieces per box
ACC300009	HEAT RECOVERY UNIT USABLE WITH BMS SYSTEMS "SILENCE AIR PLUS"	PCS	1

COMPACT CEILING-MOUNTED DUCTABLE STATIC HEAT RECOVERY UNITS

TECHNICAL SPECIFICATIONS

- For false ceiling installation
- Power supply: 230V - 50 Hz
- Centrifugal EC motors
- Removable grade G4 filters
- Couplers: Ø 150 mm
- High-efficiency polystyrene heat exchanger pack
- Removable delivery and intake filters
- Equipped with coupling for condensate drain

RÉCUPÉRATEUR DE CHALEUR COMPACT, GAINABLE ET STATIQUE

CARACTÉRISTIQUES TECHNIQUES

- Pour l'installation de faux-plafond
- Alimentation : 230V - 50 Hz
- Moteurs centrifuges EC
- Filtres amovibles grade G4
- Raccords : Ø 150 mm
- Pack d'échange en polystyrène à haut rendement
- Filtres d'entrée et de sortie amovibles
- Équipé d'un raccord pour la vidange du condensat

KANALISIERBARER KOMPAKTER FÜR ZWISCHENDECKEN WÄRMERÜCKGEWINNER

TECHNISCHE EIGENSCHAFTEN

- Für die Montage an einer Zwischendecke
- Versorgung: 230V - 50 Hz
- Zentrifugale EC-Motoren
- Herausnehmbare Filter, Grad G4
- Anschlüsse: Ø 150 mm
- Hocheffiziente Polystyrol-Austauschpaket
- Herausnehmbare Einlass- und Auslassfilter
- Mit Anschluss für Kondensatableitung

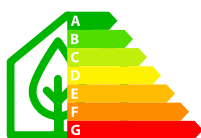

High Efficiency



Cross flow



Flow regulator supplied



G4 Filter

Extremely compact

LATERAL VIEW



EXCHANGE PACK
Extraction from the side

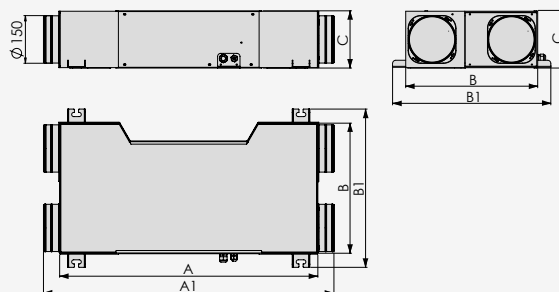

DIMENSIONS [mm]

A	A1	B	B1	C
805	905	405	495	180

ELECTRICAL AND PERFORMANCE DATA

TYPE	Bidirectional Residential Ventilation Unit
POWER SUPPLY	230 V - 50 Hz
ELECTRICAL POWER ABSORBED AT MAXIMUM FLOW RATE FOR SINGLE FLOW [W]	27,5
ELECTRICAL POWER ABSORBED AT MAXIMUM CAPACITY [W]	55
MAXIMUM CAPACITY (A 100 PA) [m³/h]	120
THERMAL EFFICIENCY OF THE EXCHANGE PACK	88%
ENERGY CLASS (CLASS SEC TEMPERATE CLIMATE)	A
TYPE OF HEAT RECOVERY	Recovery
TYPE OF CONTROL	Manual control

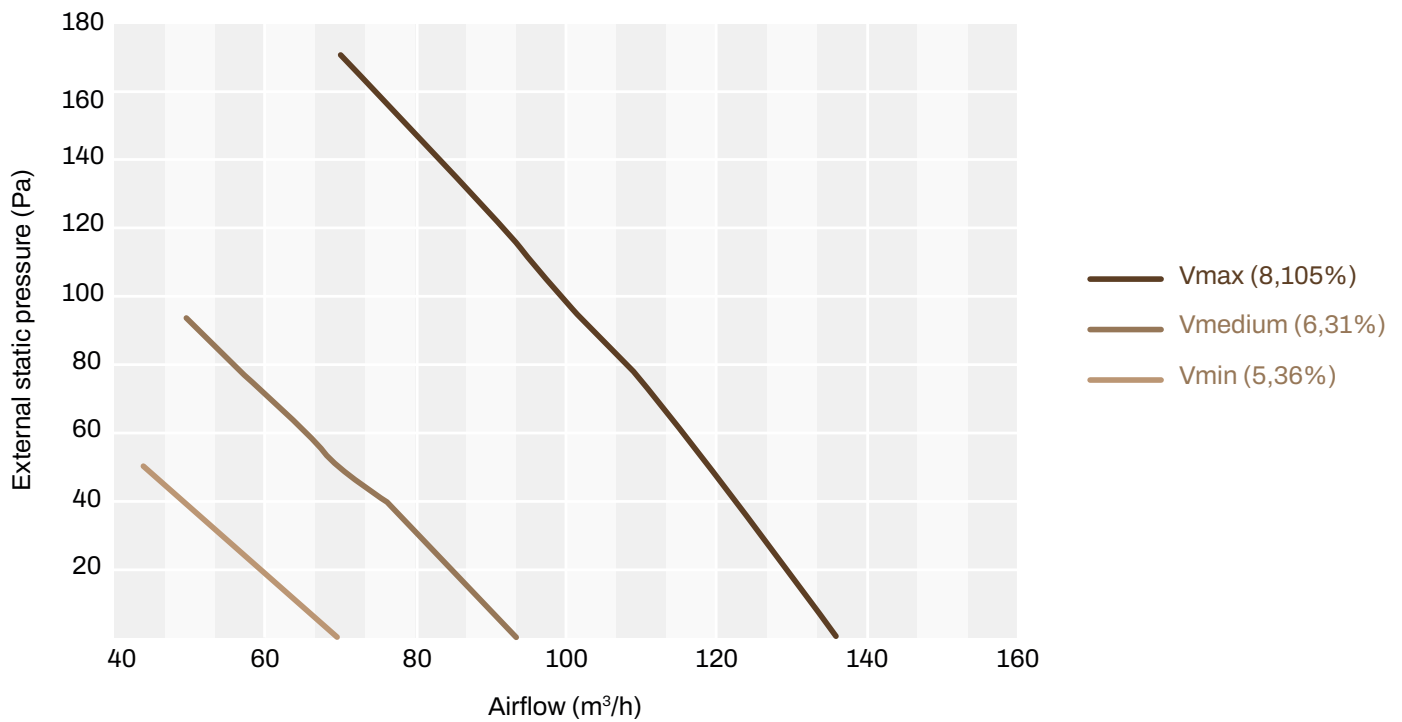

CODE	DESCRIPTION	U.M.	Pieces per box
ACD200064	COMPACT 30 COMPACT CEILING-MOUNTED DUCTABLE STATIC HEAT RECOVERY UNIT	PCS	1

Datasheet

HIGH-EFFICIENCY CEILING-MOUNTED STATIC HEAT RECOVERY UNIT WITH AUTOMATIC MECHANICAL BY-PASS

RÉCUPÉRATEUR DE CHALEUR STATIQUE GAINABLE À HAUT RENDEMENT AVEC BY-PASS MÉCANIQUE AUTOMATIQUE

HOCHEFFIZIENTER ZENTRALER KANALISIERBARER WÄRMERÜCKGEWINNER MIT AUTOMATISCHEM MECHANISCHEM BYPASS FÜR ZWISCHENDECKEN

TECHNICAL SPECIFICATIONS

- For false ceiling installation
- Power supply 230V - 50Hz
- Centrifugal EC motors
- Removable grade G4 filters
- Ø 150 mm couplings
- High-efficiency polystyrene heat exchanger pack
- Removable delivery and intake filters
- Equipped with coupling for condensate drain
- Equipped with automatic bypass activation
- Includes wall-mounted control panel with dirty filter alert

CARACTÉRISTIQUES TECHNIQUES

- Pour l'installation de faux-plafond
- Alimentation 230 V - 50 Hz
- Moteurs centrifuges EC
- Filtres amovibles grade G4
- Raccords Ø 150 mm
- Pack d'échange en polystyrène à haut rendement
- Filtres d'entrée et de sortie amovibles
- Équipé d'un raccord pour la vidange du condensat
- Équipé de by-pass à actionnement automatique
- Livré avec panneau de commande mural avec signalisation de filtre sale

TECHNISCHE EIGENSCHAFTEN

- Für die Montage an einer Zwischendecke
- Stromversorgung 230V - 50Hz
- Zentrifugale EC-Motoren
- Herausnehmbare Filter, Grad G4
- Ø 150 mm Anschlüsse
- Hocheffiziente Polystyrol-Austauschpaket
- Herausnehmbare Einlass- und Auslassfilter
- Mit Anschluss für Kondensatableitung
- Mit automatisch betätigtem Bypass
- Komplett mit Wandbedienfeld mit Meldung verschmutzter Filter

Ceiling mounted

Grade F7 filters on request



Wall control panel included



Advanced configuration terminal for installer (optional)

Filter extraction from below

Filter extraction from below

Bottom view without closing caps

Exchange pack extraction from below

Locking cross bar

Note: to extract the exchange pack it's necessary to remove the locking cross bar

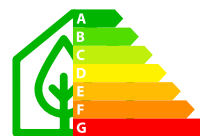
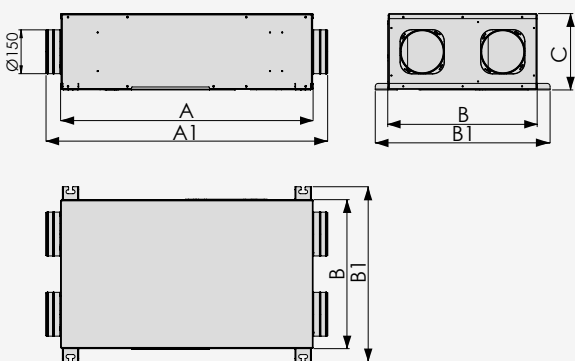

High Efficiency



Cross flow

Virtual Reality



Can be integrated with **BMS SYSTEMS** (building automation)

DIMENSIONS [mm]

A	A1	B	B1	C
850	948	500	589	257



ELECTRICAL AND PERFORMANCE DATA

TYPE	Bidirectional Residential Ventilation Unit
POWER SUPPLY	230 V - 50 Hz
ELECTRICAL POWER ABSORBED AT MAXIMUM FLOW RATE [W]	85
MAXIMUM FLOW RATE (A 100 PA) [M ³ /H]	215
THERMAL EFFICIENCY OF THE EXCHANGE PACK	85%
ENERGY CLASS (CLASS SEC TEMPERATE CLIMATE)	A
TYPE OF HEAT RECOVERY	Recovery
TYPE OF CONTROL	Local environmental control

TECHNICAL CHARACTERISTICS OF RECUPERATOR

BODY MATERIAL	Electro-galvanised-plated sheet
INSULATION	Closed-cell polyethylene 3 mm
FILTER: SUPPLY/RETURN	G4
DUCT DIAMETER [mm]	Ø150
TYPE OF RECUPERATOR	Cross-flow

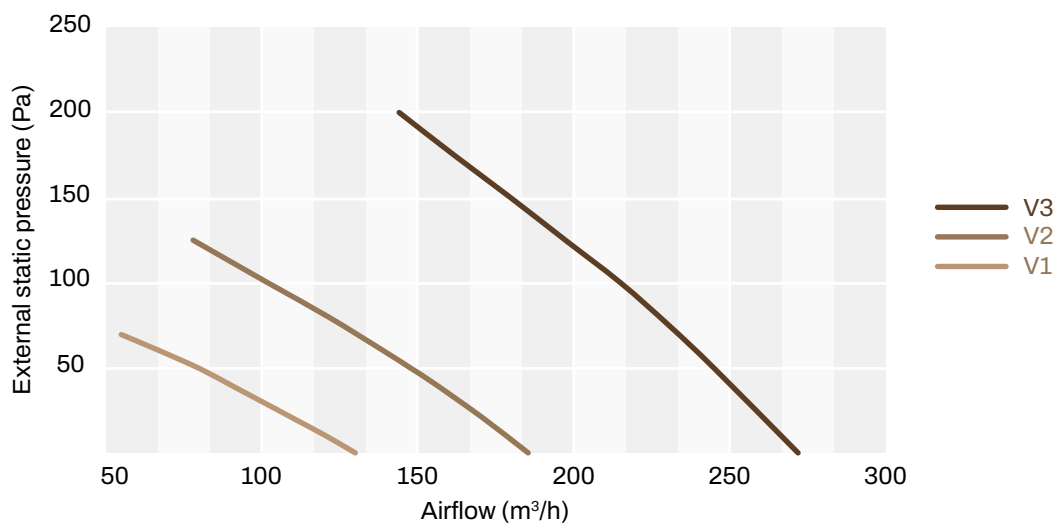

CODE	DESCRIPTION	U.M.	Pieces per box
ACD200065	TOTAL AIR 200 HIGH-EFFICIENCY CEILING-MOUNTED DUCTABLE STATIC HEAT RECOVERY UNIT WITH AUTOMATIC MECHANICAL BY-PASS	PCS	1
ACC200015	ADVANCED SETUP DISPLAY FOR INSTALLERS (OPTIONAL)	PCS	1
ACC200016	CABLE FOR CONFIGURATING DISPLAY	PCS	1

Datasheet





NEW

LINEAR DIFFUSERS RECOMMENDED AND SUITABLE FOR MVHR SYSTEMS

The **new Tecnosystemi linear diffusers** are an innovative solution for residential and commercial air management. Designed to ensure a silent, uniform air flow, these diffusers blend perfectly into any space with their **minimal, modern design**. They offer high performance, **improving the efficiency** of the ventilation system and guaranteeing **excellent comfort** in any room.

Versatile and **easy to install**, they are ideal for spaces of different sizes and uses, while the advanced technology ensures precise air flow control, minimising heat dispersion and **improving energy efficiency**.

PVC PLASTIC

LINEAR DELIVERY DIFFUSERS
IN ANTI-CONDENSATE PVC PLASTIC
WITH DAMPER 1-2-3-4 SLOTS

page 64*
page 66*
page 68*
page 70*

LINEAR DELIVERY DIFFUSERS IN
ANTI-CONDENSATE PVC PLASTIC
WITH DAMPER AND CENTRAL
BAFFLE 1-2-3-4 SLOTS

page 73*
page 75*
page 77*
page 79*

LINEAR INTAKE DIFFUSERS IN
ANTI-CONDENSATE PVC PLASTIC
1-2-3-4 SLOTS

page 82*
page 84*
page 86*
page 88*

LINEAR RETRACTING DELIVERY
AND INTAKE DIFFUSERS IN ANTI-
CONDENSATE PVC PLASTIC
WITH INSULATED PLENUM

page 93*
page 97*
page 101*
page 107*

ALUMINIUM

LINEAR DELIVERY DIFFUSERS
IN ALUMINIUM WITH DAMPER
1-2-3-4 SLOTS

page 65*
page 67*
page 69*
page 71*

LINEAR DELIVERY DIFFUSERS
IN ALUMINIUM WITH DAMPER
AND CENTRAL BAFFLE
1-2-3-4 SLOTS

page 74*
page 76*
page 78*
page 80*

LINEAR INTAKE DIFFUSERS
IN ALUMINIUM
1-2-3-4 SLOTS

page 83*
page 85*
page 87*
page 89*

LINEAR RETRACTING
DELIVERY AND INTAKE
DIFFUSERS IN ALUMINIUM
WITH INSULATED PLENUM

page 95*
page 99*
page 104*
page 110*

*See Project Wind catalogue

TS
HRVU



TS-HRVU



THE NEW COMPACT AND LIGHTWEIGHT
MVHR DESIGNED BY TECNOSYSTEMI

The TS-HRVU system represents an advanced solution for air exchange in residential environments, thanks to the integration of a sensitive counterflow heat exchanger that allows heat recovery during the ventilation process.

This type of technology ensures superior energy efficiency, reducing the need for artificial heating or cooling, while improving indoor air quality.

Advanced technology allows automatic management of air flows, which can be adjusted according to the specific needs of users, improving the overall energy efficiency of the home.

The TS-HRVU ensures not only effective ventilation, but also significant energy savings, improving indoor air quality without compromising thermal comfort.

Thanks to its ability to optimize heat recovery, it is particularly suitable in residential environments that require continuous air exchange and a high standard of energy efficiency.



Extractable ISO
Coarse filters
60% G4



Modbus BMS
connection



Thermo-acoustic
insulation



Brushless EC
motors



Antifreeze feature



Reversible upon
assembly

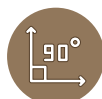

90° adjustable
aeraulic
connections



4 temperature
sensors



Free Cooling
Free Heating

THE IMPORTANCE OF THE MVHR

MVHR (Mechanical Ventilation Heat Recovery) is essential to ensure a healthy and comfortable environment inside buildings. It allows you to optimally manage air exchange, avoiding the accumulation of moisture, pollutants and CO₂.

A good MVHR improves air quality, **reduces the risk of mould and bacteria formation and contributes to energy savings**, since it allows heat to be recovered from the extracted air and reduces the heating requirement. In addition, **it is essential for well-being, as quality air can prevent breathing problems and improve concentration and comfort indoors.**



Healthy Environment



Increases energy efficiency



Reduces the risk of Mould and Bacteria



Increases Comfort



Reduces Humidity and CO₂

Self-supporting structure in recycled EPP (PPE)

Coarse 60% Filter G4

Condensate drain

EC Brushless motors

Heat exchanger pack

Fixing brackets

90° adjustable aeraulic connections

VENTILATION UNIT WITH HEAT RECOVERY

UNITÉ DE VENTILATION AVEC RÉCUPÉRATION DE CHALEUR

LÜFTUNGSEINHEIT MIT WÄRMERÜCKGEWINNUNG

TECHNICAL SPECIFICATIONS

- Ideal for wall or ceiling installation
- Coarse filter 60% (G4) on the suction ducts
- RS485 communication port with modbus protocol
- Made of sintered expanded polypropylene
- Indoor and outdoor air filtration
- High-efficiency heat and humidity recovery
- Thermo-acoustic insulation
- Brushless EC motors
- Air quality index (AQI) monitoring
- 90° directional grilles

CARACTÉRISTIQUES TECHNIQUES

- Idéal pour une installation au plafond et murale
- Filtre Coarse 60 % (G4) sur les conduits d'aspiration
- Porte de communication RS485 avec protocole modbus
- Réalisé en polypropylène expansé fritté
- Filtration de l'air interne et externe
- Récupération de chaleur et d'humidité à haut rendement
- Isolation thermo-acoustique
- Moteurs Brushless EC
- Suivi de l'indice de qualité de l'air (AQI)
- Événements orientables à 90°

TECHNISCHE EIGENSCHAFTEN

- Ideal für die Decken- und Wandmontage
- Filter Coarse 60 % (G4) an den Ansaugkanälen
- Kommunikationsanschluss RS485 mit modbus-protokoll
- Gefertigt aus gesintertem Polypropylen-Schaum
- Innen- und außenluftfiltration
- Hocheffiziente wärme- und feuchtigkeitsrückgewinnung
- Wärme- und Schalldämmung
- Brushless EC Motoren
- Überwachung des luftqualitätsindex (AQI)
- Öffnung um 90° ausrichtbar



Made from **RECYCLED** EPP (PPE)



Control device supplied with mod. TS120



Control device supplied with mod. TS180, TS250, TS320, TS380 and TS500

NEW

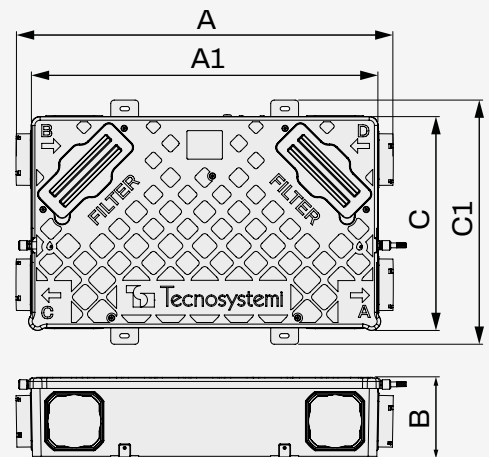

Available from February 2025

CODE	DESCRIPTION	DIMENSIONS [mm]					U.M.	Pieces per box
		A	A1	B	C	C1		
ACD200068	HRVU HEAT RECOVERY UNIT TS120 0/10V	1100	990	230	610	700	PCS	1
ACD200067	HRVU TS180 RF HEAT RECOVERY UNIT	1100	990	230	610	700	PCS	1
ACD200066	HRVU TS250 RF HEAT RECOVERY UNIT	1100	990	230	610	700	PCS	1
ACD200075	HRVU TS320 RF HEAT RECOVERY UNIT	1100	990	230	610	700	PCS	1
ACD200072	HRVU TS380 RF HEAT RECOVERY UNIT	1250	1140	320	830	920	PCS	1
ACD200073	HRVU TS500 RF HEAT RECOVERY UNIT	1250	1140	320	830	920	PCS	1
ACD200069	CONTROL FOR CMV DISPLAY WITH PROGRAMMING						PCS	1
ACD200070	CLOSING PLATE FOR CONTROLS BOX503						PCS	1
ACD200071	FILTER F7 ISO EMP >50% FOR MOD. 120-180-250-320 M3H PLEATED						PCS	1
ACD200074	FILTER F7 ISO EPM1 >50% FOR MOD. 380-500 M3H PLEATED						PCS	1

ELECTRICAL DATA						
Model	HRVU TS120	HRVU TS180	HRVU TS250	HRVU TS320	HRVU TS380	HRVU TS500
Power supply	230 V – 50 Hz	230 V – 50 Hz	230 V – 50 Hz	230 V – 50 Hz	230 V – 50 Hz	230 V – 50 Hz
Maximum power(W)	50	70	120	160	180	220
Maximum current (A)	0.3	0.3	0.5	0.7	0.8	1
Insulation class	Class 1	Class 1	Class 1	Class 1	Class 1	Class 1
IP rating	IP22	IP22	IP22	IP22	IP22	IP22
Operating temperature in the installation compartment (°C)	-10/+40					
Relative operating humidity (%RH at 25° C)	< 85 %	< 85 %	< 85 %	< 85 %	< 85 %	< 85 %
PERFORMANCE DATA						
Volumetric flow rate (m3/h) maximum at 100 Pa	120	180	250	320	380	500
Energy rating (SEC temperate climate)	A	A	A	A	A	A
Heat Efficiency (%)	87	85	83	82	83	81
Type of heat recovery unit	Sensitive backflow heat exchanger HRC1a					
Thermal by-pass	Not present	Electronically operated mechanical system				
Minimum External Air Temperature (°C)	-15	-15	-15	-15	-15	-15
Reversible flows	yes	yes	yes	yes	yes	yes
Anti-freeze function	no	yes	yes	yes	yes	yes
Air filters as standard	ISO COARSE 65% (G4)					
Additional air filters (upon request)	ISO ePM1 >50% (F7)					
Sound Power LWA	46	47	48	46	46	48
CONSTRUCTION CHARACTERISTICS						
Type of motors	Brushless EC					
Body material	Expanded polypropylene (EPP) with galvanised sheet metal supports					
Dimensions(mm)	1100x230x610	1100x230x610	1100x230x610	1100x230x610	1250x320x830	1250x320x830
Weight (kg)	14	14	14	14	16	16
Aeraulic fittings (Ø mm)	150	150	150	150	200	200
Condensate drain	Threaded ½” or hose connector	Threaded ½” or hose connector	Threaded ½” or hose connector	Threaded ½” or hose connector	Threaded ½” or hose connector	Threaded ½” or hose connector
CONTROLS						
Remote control	0-10V regulator	4-button 3-speed digital control + timer mode				
Weekly programming	no	Control available on request				
BMS control	0-10 V	MODBUS				

Preliminary data subject to change. Consult the data sheets to obtain up-to-date data.



90° CAP ADJUSTABLE AERAULIC CONNECTIONS

The aeraulic connections can be oriented at 90° thanks to the quick coupling and uncoupling system and the airtight plugs.



VERTICAL CEILING OR WALL MOUNTING

90° ADJUSTABLE AERAULIC CONNECTIONS

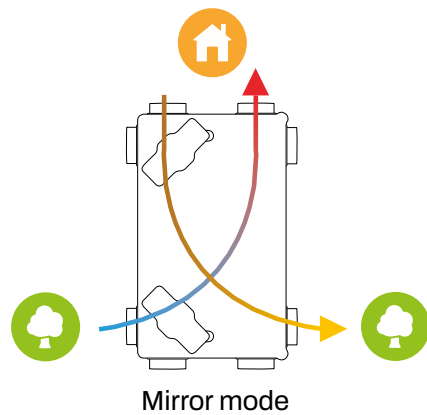
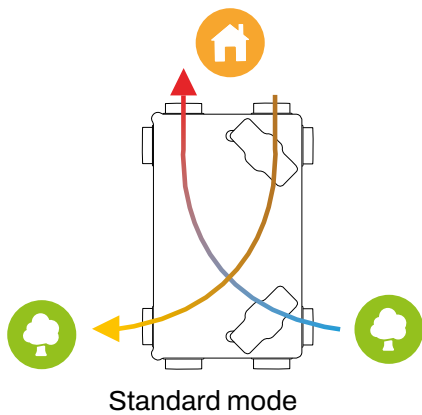
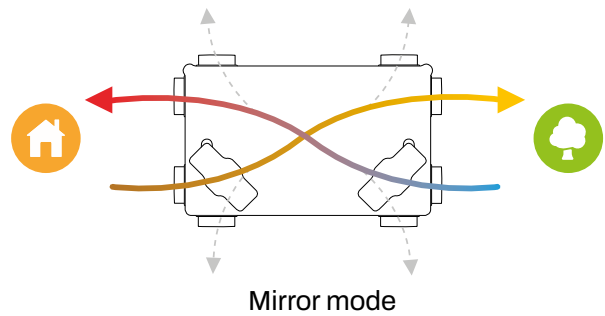
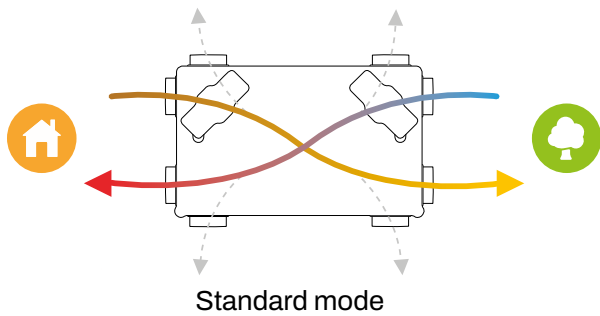

Accessories available separately



Control for MVHR display with weekly programming 230V



Closing plate for controls BOX503



ISO and PM10 filter (F7)

RECOVERY CAPACITY AND PERFORMANCE DIAGRAMS



MADE IN ITALY



Max speed
 Mid speed
 Min speed

TS-HRVU 120 m³/h

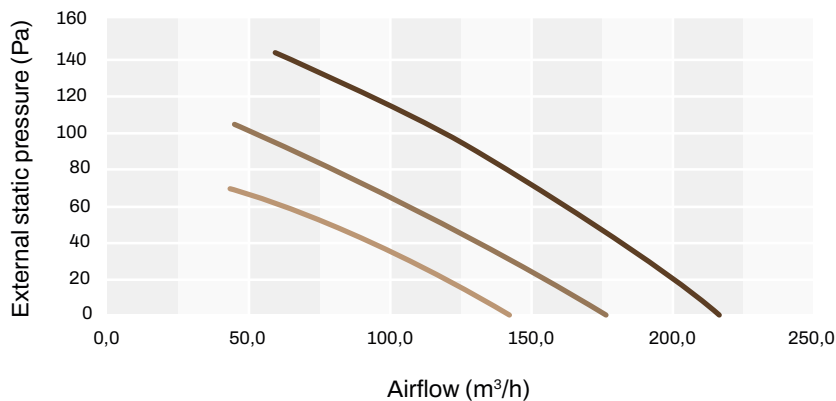

TS-HRVU 180 m³/h

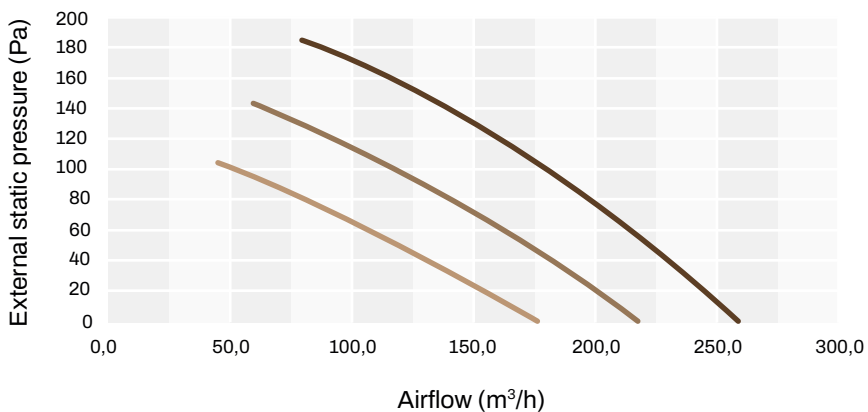

TS-HRVU 250 m³/h

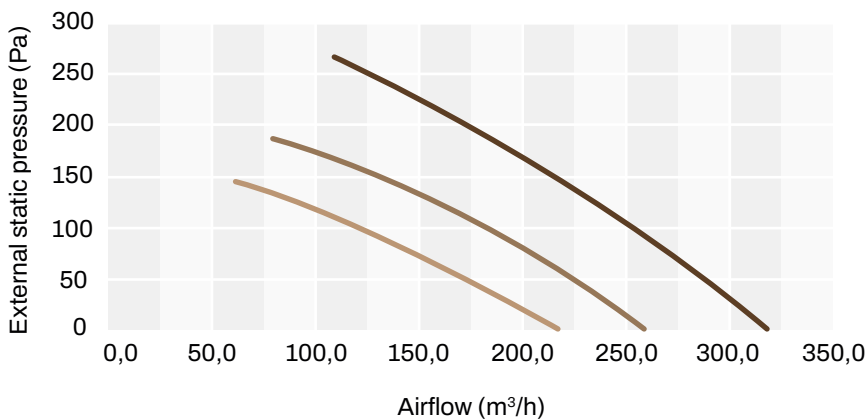

Preliminary data subject to change. Consult the data sheets to obtain up-to-date data.

RECOVERY CAPACITY AND PERFORMANCE DIAGRAMS



Max speed
 Mid speed
 Min speed

TS-HRVU 320 m³/h

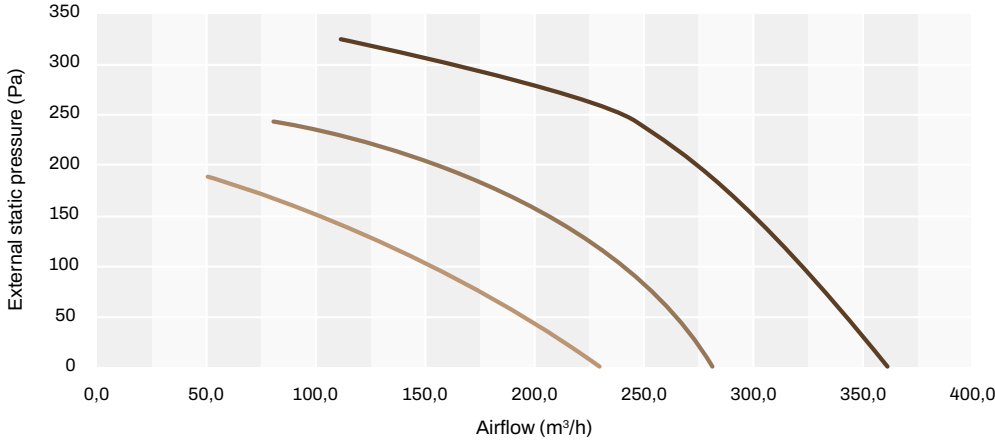

TS-HRVU 380 m³/h

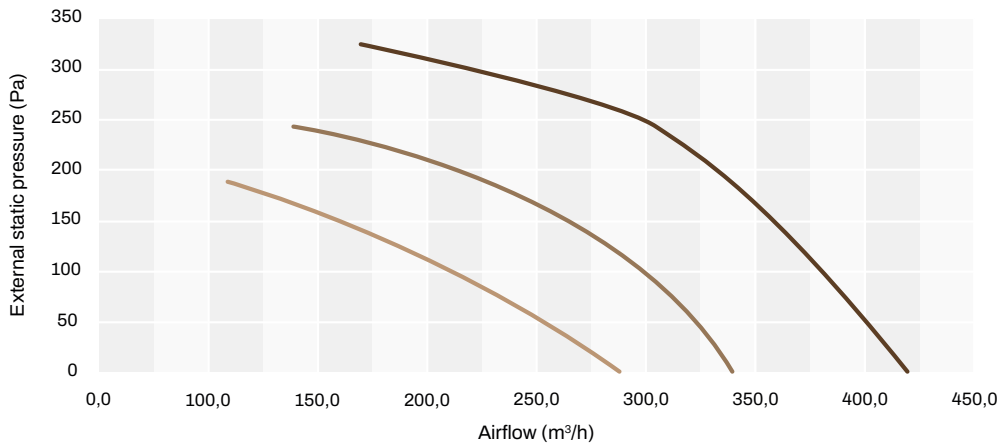

TS-HRVU 500 m³/h

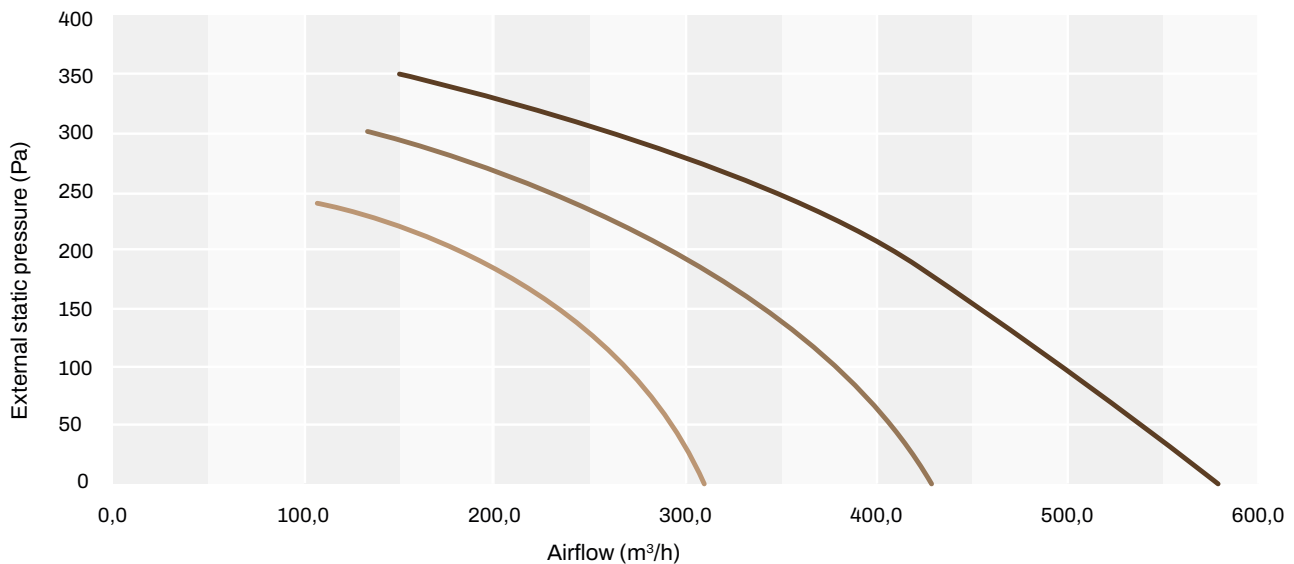

Preliminary data subject to change. Consult the data sheets to obtain up-to-date data.



WHY INSTALL A MVHR SYSTEM IN SCHOOLS?

MVHR systems operate continuously, 24 hours a day, ensuring a fresh, healthy, clean air without opening the windows.

TECNOSYSTEMI HAS EXPANDED ITS RANGE TO INCLUDE NEW HEAT RECOVERY UNITS DESIGNED AND ENGINEERED FOR ALL SCHOOL BUILDINGS.

Controlled mechanical ventilation systems are designed to be set up during the construction or renovation of a house, but decentralised solutions may also be adopted (or one-off MVHR devices), which can be installed in individual rooms, even in finished buildings.

With a MVHR system you will have a safe, enduring benefits regarding physical well-being and air quality in your home, saving you money and time spent in opening windows.

WHAT ARE THE RISKS INVOLVED IN KEEPING WINDOWS OPEN?



More energy is wasted

It is not advisable to keep windows open for extended periods of time, even if they are only partially open or ajar, since cold air flows continue to enter, lowering the temperature in the classroom, and heating systems have to work much harder to provide heat.



Greater risk of becoming ill

To ensure air circulation, windows are left open. Students are thus compelled to wear coats, hats, gloves and scarves during class time.



Entry of smog and of atmospheric pollution

Today we live in increasingly polluted environments, and the air we breathe, especially in cities, is becoming increasingly dirty and harmful. Ventilation by opening windows is, unfortunately, no longer a valid option.



VERTICAL NON-DUCTED VENTILATION UNIT

TECHNICAL SPECIFICATIONS

- Non-ducted ventilation unit
- Evo 300 maximum flow capacity 400 m³/h
- Evo 800 maximum flow capacity 1000 m³/h
- Polypropylene counter-flow heat recovery unit with >90% efficiency
- EC centrifugal fans, backward curved blades, low consumption
- Low pressure drop filters F7 (ePM1 70%) for renewal and exhaust air
- Self-supporting structure in pre-painted metal sheet
- Rock wool thermal/acoustic insulation th. 50 mm
- Integrated by pass for free-cooling / free-heating (motorised drive with automatic control)
- Available with Evo and Evo Plus control



UNITÉS DE VENTILATION VERTICALE SANS CONDUIT

CARACTÉRISTIQUES TECHNIQUES

- Unités de ventilation sans conduit
- Evo 300 débit maximal 400 m³/h
- Evo 800 débit maximal 1000 m³/h
- Unité de récupération de chaleur contre-flux, en polypropylène avec efficacité >90%
- Ventilateurs EC, centrifuges pales arrières à faible consommation
- Filtre faible perte de charge: F7 (ePM1 70%) pour air de renouvellement et extraction
- Structure autoportante en tôle pré-peinte
- Isolation thermique/acoustique en laine de roche ép. 50 mm
- By pass intégré pour free-cooling/free-heating (actinement motorisé avec commande automatique)
- Disponible avec les contrôles Evo et Evo Plus



VERTIKALER LÜFTUNGSEINHEIT NICHT KANALISIERBAR

TECHNISCHE EIGENSCHAFTEN

- Nicht kanalisierbare Lüftungseinheit
- Evo 300 maximale Förderleistung 400 m³/h
- Evo 800 maximale Förderleistung 1000 m³/h
- Gegenstrom-wärmerückgewinnungseinheit, aus Polypropylen, mit Wirkungsgrad >90%
- Ec-Ventilatoren, zentrifugal, rückwärts gekrümmt, niedriger Verbrauch
- Filter mit geringem Druckverlust: f7 (ePM1 70%) für frische Luft und Belüftung
- Selbsttragende Struktur aus vorlackiertem Metallblech
- Wärme- und schalldämmung aus Steinwolle, 50 mm dick
- Integrierter Bypass für freie Kühlung / freie Heizung (Antrieb mit automatischer Steuerung)
- Erhältlich mit den Steuerungen Evo und Evo Plus

HORIZONTAL MODEL

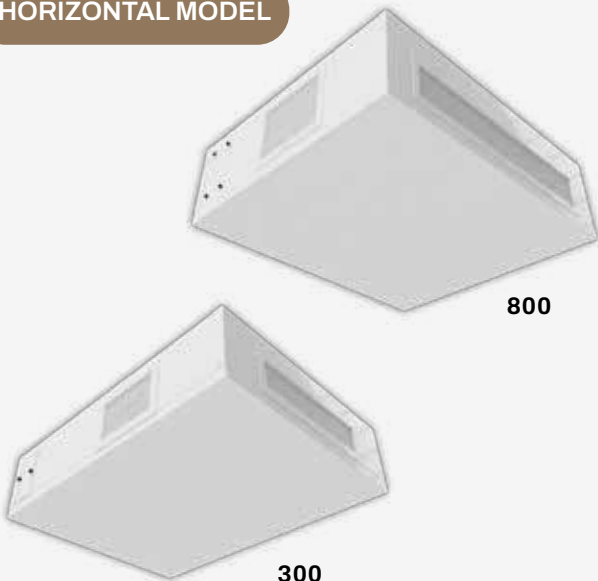

VERTICAL MODEL



Available on request

CODE	DESCRIPTION	DIMENSION [mm] L x D x H	WEIGHT [kg]	U.M.	Pieces per box
ACC200001	"TOTAL CLASS EVO" 300 - HORIZONTAL	1020x1350x335	95	PCS	1
ACC200002	"TOTAL CLASS EVO PLUS" 300 - HORIZONTAL	1020x1350x335	95	PCS	1
ACC200003	"TOTAL CLASS EVO" 800 - HORIZONTAL	1555x1355x470	148	PCS	1
ACC200004	"TOTAL CLASS EVO PLUS" 800 - HORIZONTAL	1555x1355x470	148	PCS	1
ACC200005	"TOTAL CLASS EVO" 300 - VERTICAL	785x475x1625	95	PCS	1
ACC200006	"TOTAL CLASS EVO PLUS" 300 - VERTICAL	785x475x1625	95	PCS	1
ACC200007	"TOTAL CLASS EVO" 800 - VERTICAL	1265x475x1925	148	PCS	1
ACC200008	"TOTAL CLASS EVO PLUS" 800 - VERTICAL	1265x475x1925	148	PCS	1

Datasheet



Datasheet



TECHNICAL DATA	EVO 300 / EVO 300 PLUS	EVO 800 / EVO 800 PLUS
POWER SUPPLY [V]	230	230
FREQUENCY [HZ]	50-60	50-60
CURRENT [A]	2.7	2.8
POWER [W]	350	380
DIMENSIONS HORIZONTAL MODEL (W X D X H)*	1020x1350x335 mm	1555x1355x470 mm
DIMENSIONS VERTICAL MODEL (W X D X H)*	785x475x1625 mm	1265x475x1925 mm
Ø PIPES [MM]	2 x 200	2 x 315
WEIGHT [KG]	95	148
FLOW CAPACITY [M ³ /S]	0.1	0.277
ELECTRICAL POWER CONSUMPTION [KW]	0.327	0,377
SPECIFIC VENTILATION POWER [W/(M ³ /S)]	1378	1189
FRONT SPEED AT NOMINAL CAPACITY [M/S]	1.56	1.42
NOMINAL EXTERNAL PRESSURE [PA]	358	50
VENTILATION COMPONENTS INTERNAL PRESSURE DROP [PA]	259	269
FAN STATIC EFFICIENCY	39.1 %	49.3 %
SOUND PRESSURE LEVEL [DB(A)]	36	34

* excluding sleeves and condensate drains

Flows

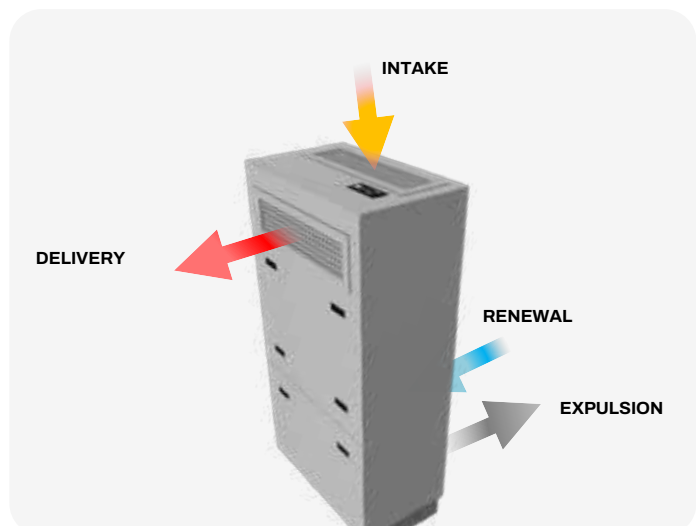
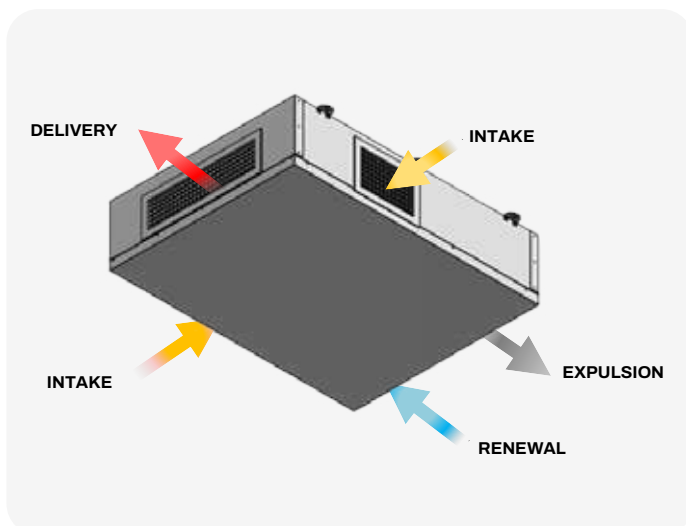

Control unit type



EVO

The remote buttons consists of the following: 2 keys for speed setting change and filter alarm reset; 5 signalling leds: 3 green leds to indicate active speed, 1 red led to signal the filter alarm, and 1 blue led to signal the opening of the by-pass and anti-freeze feature.; the remote control is connected via a standard network cable (non crossover) using RJ45 connectors (max. recommended length 30 m). supplied with 3 m cable as standard



EVO PLUS

Circuit board with WHITE LCD display:

- Speed setting 1,2,3 or automatic
- Automatic by-pass management for free-cooling and free-heating
- Frost protection (with heating element option),
- Filter alarm with hour counter (with pressure switch option)
- Management of humidity, temperature, air quality and CO₂ probes
- Control of water coils and pre-treatment and/or post-treatment heating elements.
- Communication via Mod. Bus.
- Integrated humidity and temperature probes

TOTAL CLASS 800

Flow rate diagrams

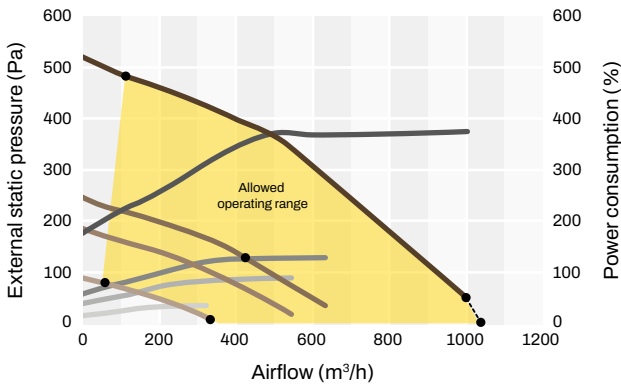

FLOW RATE

- At 40% speed
- At 60% speed
- At 70% speed
- At 100% speed

POWER CONSUMPTION

- At 40% speed
- At 60% speed
- At 70% speed
- At 100% speed

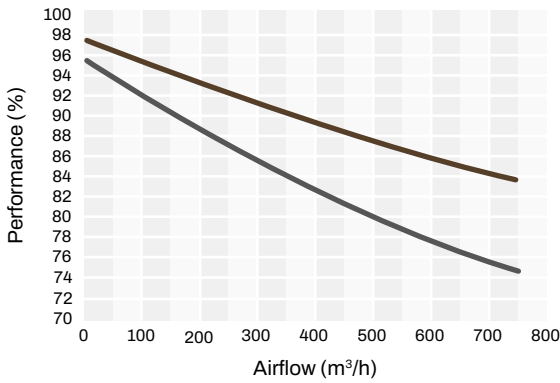

HEAT RECOVERY UNIT PERFORMANCE

- According to uni308: outdoor -5°C 80% rh - indoor 20°C 50% rh
- According to uni1253/14: outdoor -0°C - indoor 20°C (dry)

TOTAL CLASS 300

Flow rate diagrams

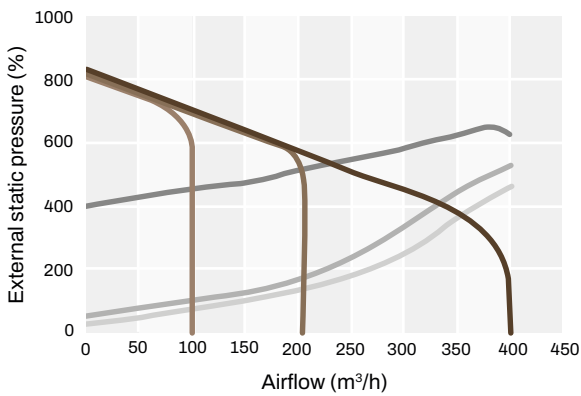

CONTROL SIGNAL

- 1.5V - flow rate 100 m³/h
- 5V - flow rate 205 m³/h
- 10V - flow rate 400 m³/h

POWER CONSUMPTION

- At max. available pressure
- 50 Pa available pressure
- 100 Pa available pressure

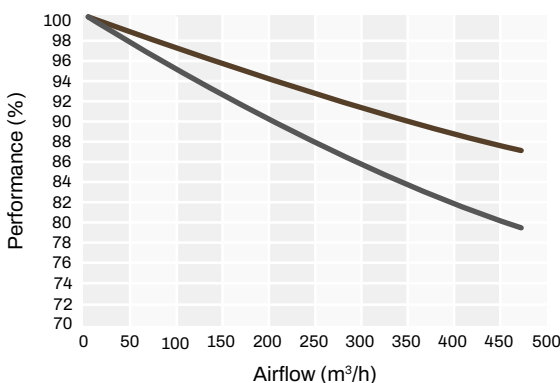

HEAT RECOVERY UNIT PERFORMANCE

- According to uni308: outdoor -5°C 80% rh - indoor 20°C 50% rh
- According to uni1253/14: outdoor -0°C - indoor 20°C (dry)

 **CEILING-MOUNTED DUCTABLE STATIC HEAT RECOVERY UNIT WITH AUTOMATIC MECHANICAL BYPASS**

TECHNICAL SPECIFICATIONS

- Plastic heat exchanger pack
- Removable grade G4 filters
- Coupling for condensate drain
- Internal insulation
- Heating battery (on request)
- Anchor brackets
- Includes wall-mounted control panel with dirty filter alert
- Equipped with automatic mechanical bypass activation

 **RÉCUPÉRATEUR DE CHALEUR STATIQUE GAINABLES AVEC DÉRIVATION MÉCANIQUE AUTOMATIQUE**

CARACTÉRISTIQUES TECHNIQUES

- Pack d'échange en plastique
- Filtres amovibles grade G4
- Raccord pour vidange de condensat
- Isolation interne
- Batterie de chauffage (sur demande)
- Supports d'ancrage
- Livré avec panneau de commande mural avec signalisation de filtre sale
- Équipé d'une dérivation à actionnement mécanique automatique

 **AN DER DECKE MONTIERTE, ZENTRALE, KANALISIERBARE WÄRMERÜCKGEWINNUNGSEINHEIT MIT AUTOMATISCHEM MECHANISCHEM BYPASS**

TECHNISCHE EIGENSCHAFTEN

- Austauschpaket aus Kunststoff
- Herausnehmbare Filter, Grad G4
- Anschluss für Kondensatablauf
- Innendämmung
- Heizbatterie (auf Anfrage)
- Verankerungswandkonsole
- Komplett mit Wandbedienfeld mit Meldung verschmutzter Filter
- Mit einem automatischen betätigtem mechanischen Bypass

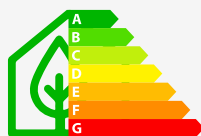
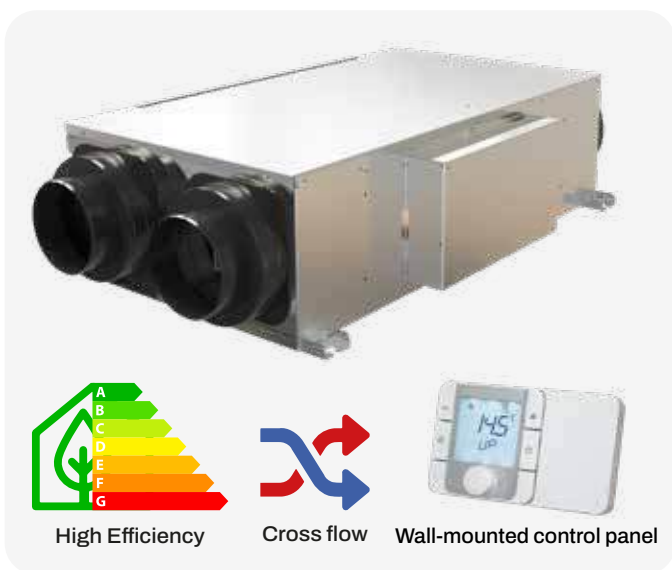

High Efficiency



Cross flow



Wall-mounted control panel

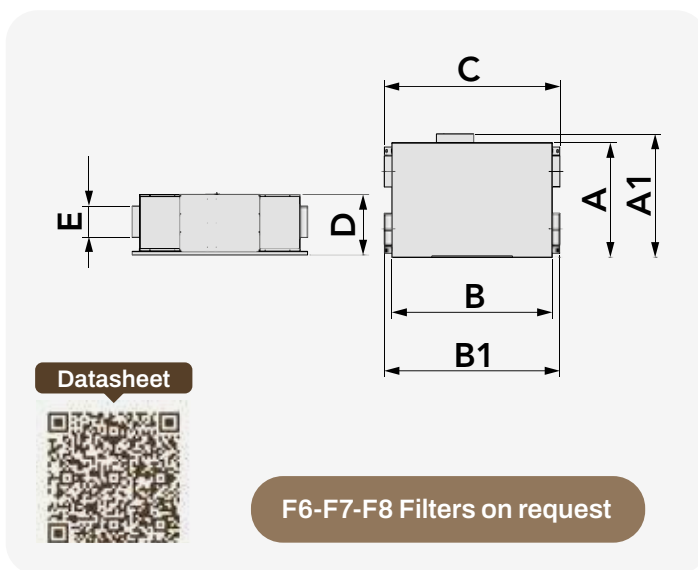

F6-F7-F8 Filters on request

MODEL	AIR FLOW RATE [m³/h]	HEAD [Pa]	EXCHANGE EFFICIENCY [%]	SOUND POWER LEVEL [dB(A)]	VOLTAGE [V]	FREQUENCY [Hz]	POWER CONSUMPTION [W]	WEIGHT [kg]
AIR PUR 300E EVO PLUS	300	430	75	40	230	50	200	55
AIR PUR 500E EVO PLUS	500	400	75	42	230	50	280	70
AIR PUR 800E EVO PLUS	800	400	75	58	230	50	420	84
AIR PUR 1300E EVO PLUS	1300	330	74	65	230	50	1100	135
AIR PUR 1700E EVO PLUS	1700	315	72	65	230	50	1100	203
AIR PUR 2500E EVO PLUS	2500	690	70	62	230	50	2080	211
AIR PUR 4000E EVO PLUS	4000	540	70	79	400	3 - 50	3000	290

CODE	MODEL	DIMENSIONS [mm]							U.M.	 Pieces per box
		A	A1	B	B1	C	D	E		
12500050	AIR PUR 300E EVO PLUS	650	720	950	1147	1006	280	150	PCS	1
12500080	AIR PUR 500E EVO PLUS	750	820	1100	1297	1156	320	200	PCS	1
12500140	AIR PUR 800E EVO PLUS	750	820	1100	1223	1156	377	250	PCS	1
12500200	AIR PUR 1300E EVO PLUS	930	1000	1300	1423	1421	490	250	PCS	1
12500230	AIR PUR 1700E EVO PLUS	1100	1170	1500	1623	1621	490	300	PCS	1
12500290	AIR PUR 2500E EVO PLUS	1300	1370	1600	1723	1721	540	350	PCS	1
12500350	AIR PUR 4000E EVO PLUS	1400	1470	1670	1793	1791	688	450	PCS	1

AIR PUR EVO PLUS 300 m³/h

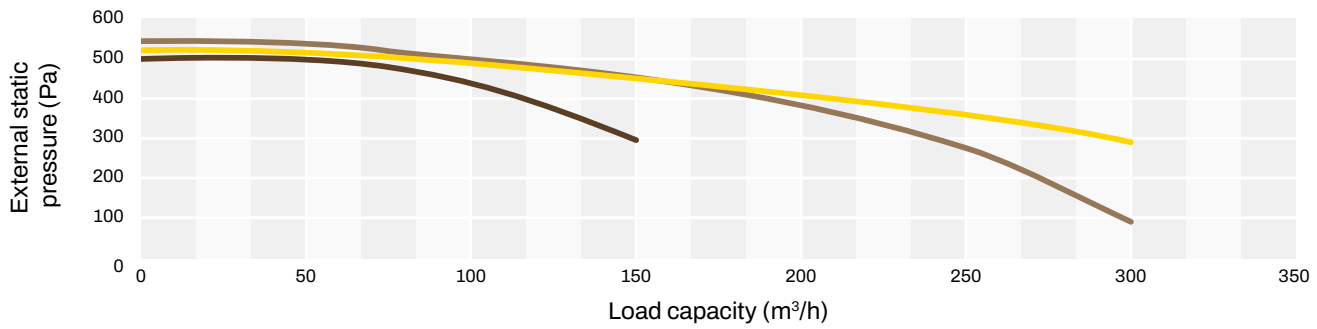

AIR PUR EVO PLUS 500 m³/h

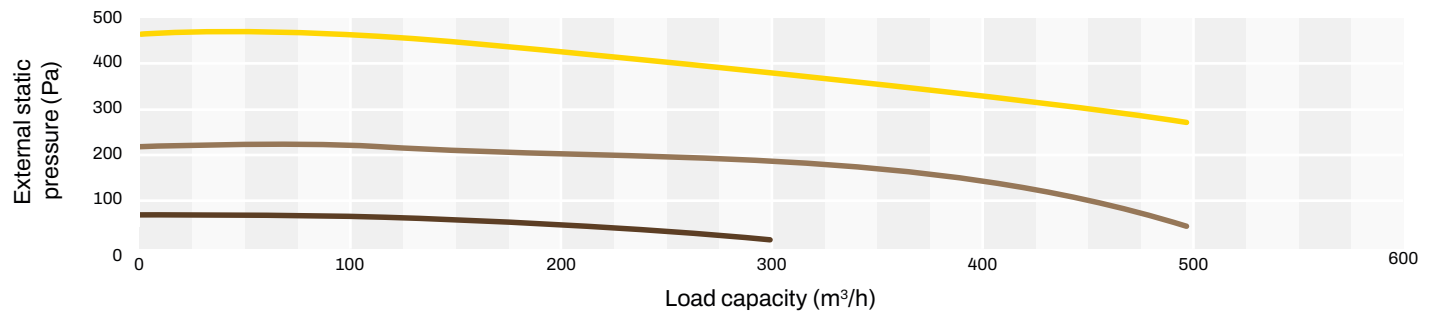

AIR PUR EVO PLUS 800 m³/h

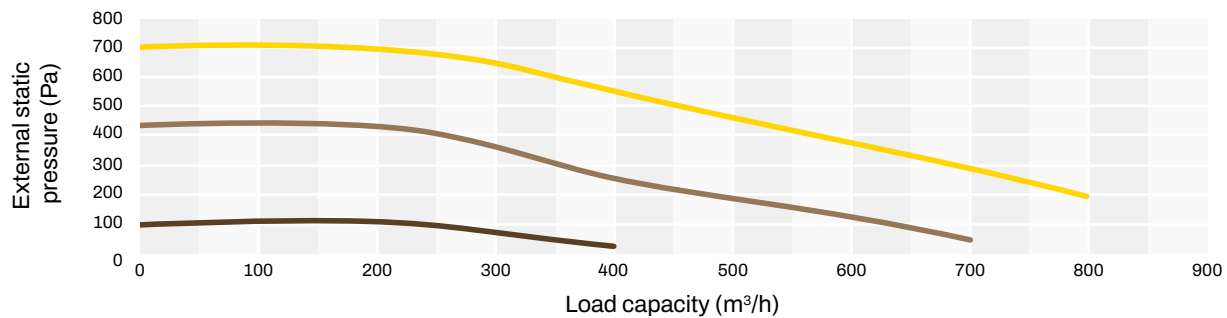

AIR PUR EVO PLUS 1300 m³/h

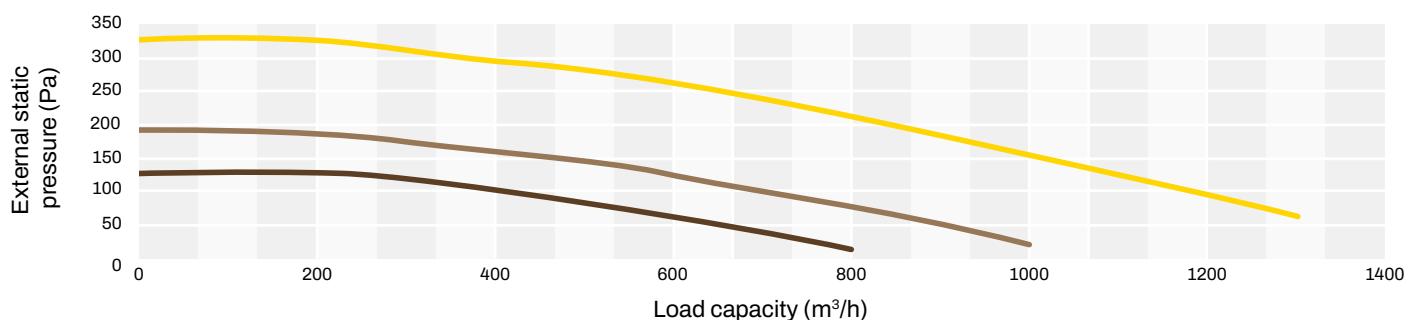

AIR PUR EVO PLUS 1700 m³/h

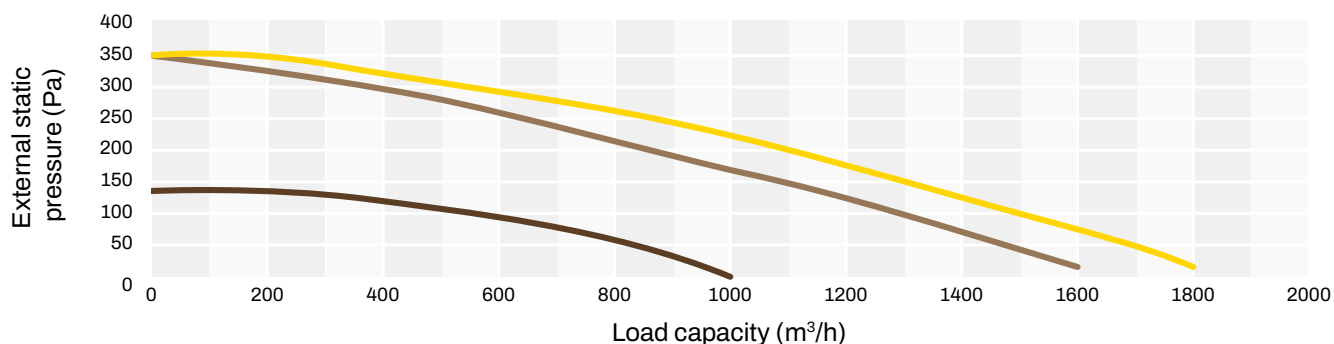

AIR PUR EVO PLUS 2500 m³/h

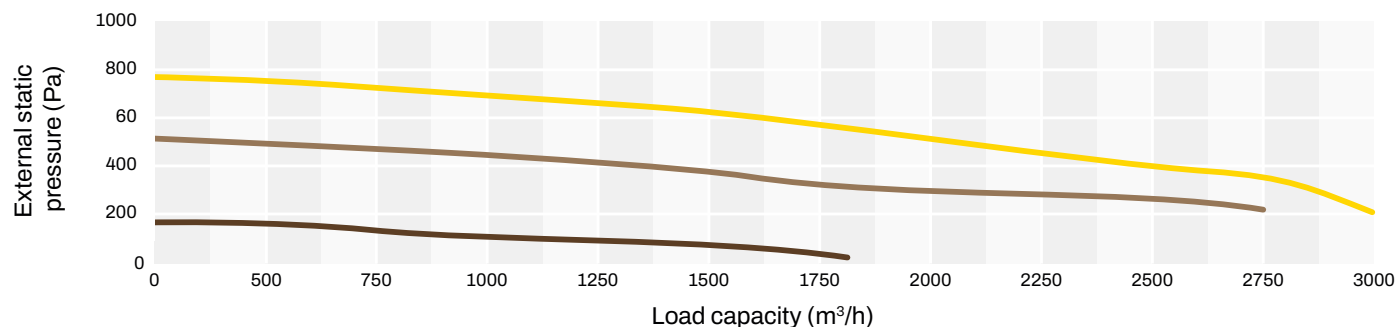

AIR PUR EVO PLUS 4000 m³/h

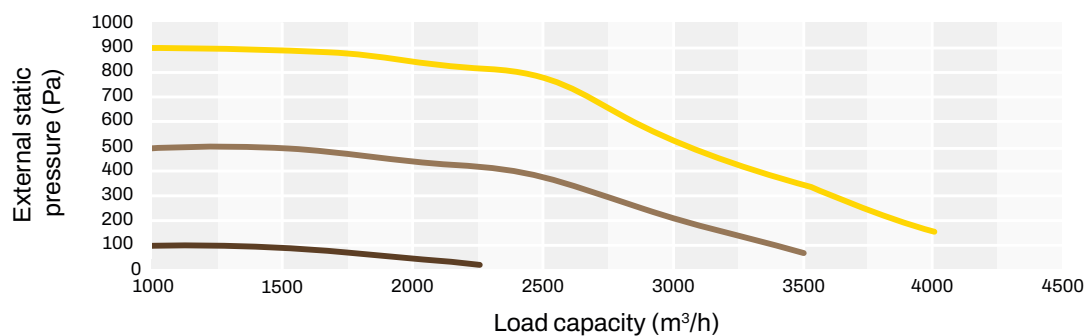

UNITED KINGDOM
HORIZONTAL STATIC HEAT RECOVERY UNIT WITH MECHANICAL BYPASS

TECHNICAL SPECIFICATIONS

- Plastic heat exchanger pack
- Removable grade G4 filters
- Coupling for condensate drain
- Internal insulation
- Heating batter (on request)
- Anchor brackets
- Equipped with manual mechanical bypass activation

FRANCE
RÉCUPÉRATEUR DE CHALEUR STATIQUE HORIZONTAL GAINABLE AVEC DÉRIVATION MÉCANIQUE

CARACTÉRISTIQUES TECHNIQUES

- Pack d'échange en plastique
- Filtres amovibles grade G4
- Raccord pour vidange de condensat
- Isolation interne
- Batterie de chauffage (sur demande)
- Supports d'ancrage
- Équipé de by-pass à actionnement mécanique manuel

GERMANY
HORIZONTALE ZENTRALE, WÄRMERÜCKGEWINNUNGSEINHEIT MIT MECHANISCHEM BYPASS

TECHNISCHE EIGENSCHAFTEN

- Austauschpaket aus Kunststoff
- Herausnehmbare Filter, Grad G4
- Anschluss für Kondensatablauf
- Innendämmung
- Heizbatterie (auf Anfrage)
- Verankerungswandkonsole
- Mit manuellem mechanischem Bypass

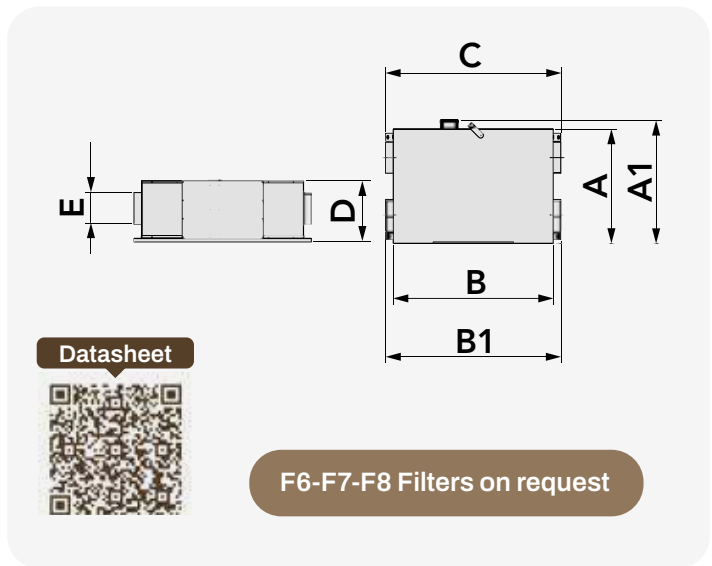

MODEL	AIR FLOW RATE [m³/h]	HEAD [Pa]	EXCHANGE EFFICIENCY [%]	SOUND POWER LEVEL [dB(A)]	VOLTAGE [V]	FREQUENCY [Hz]	POWER CONSUMPTION [W]	WEIGHT [kg]
AIR PUR 300E EVO	300	320	75	40	230	50	200	50
AIR PUR 500E EVO	500	330	75	42	230	50	356	68
AIR PUR 1000E EVO	1000	330	74	62	230	50	600	129
AIR PUR 1700E EVO	1700	290	72	65	230	50	800	193
AIR PUR 2500E EVO	2500	360	70	62	230	50	1100	224
AIR PUR 4000E EVO	4000	700	70	79	400	3 - 50	3000	290

CODE	MODEL	DIMENSIONS [mm]							U.M.	Pieces per box
		A	A1	B	B1	C	D	E		
12500040	AIR PUR 300E EVO	650	720	950	1147	1006	280	150	PCS	1
12500070	AIR PUR 500E EVO	750	820	1100	1297	1156	320	200	PCS	1
12500160	AIR PUR 1000E EVO	930	1000	1300	1423	1421	490	250	PCS	1
12500220	AIR PUR 1700E EVO	1100	1170	1500	1623	1621	490	300	PCS	1
12500280	AIR PUR 2500E EVO	1300	1370	1600	1723	1721	540	350	PCS	1
12500340	AIR PUR 4000E EVO	1400	1470	1670	1793	1791	688	450	PCS	1

AIR PUR EVO 300 m³/h

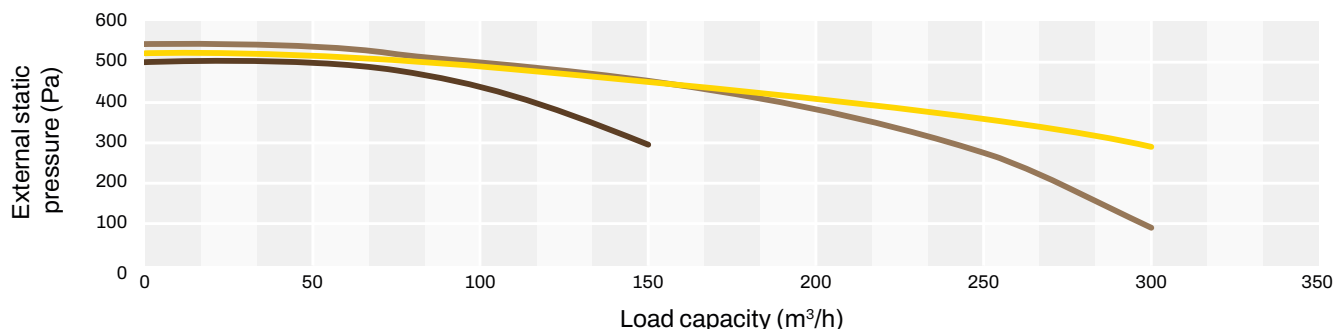

AIR PUR EVO 500 m³/h

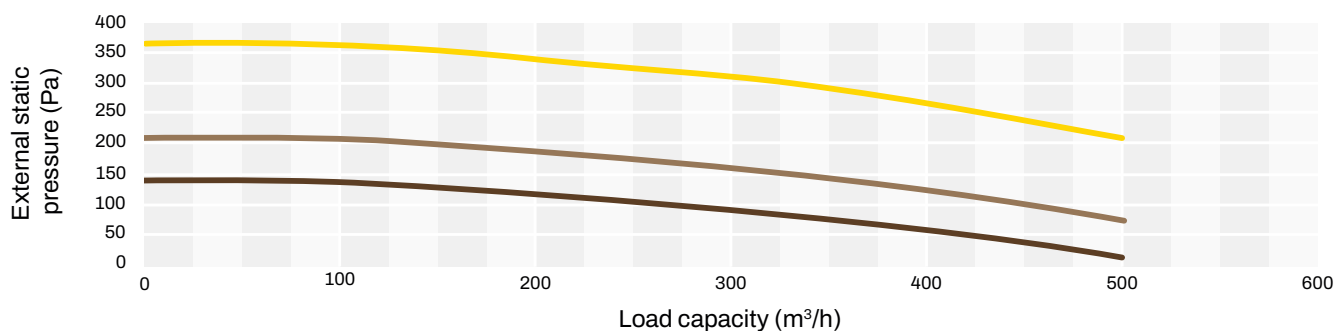

AIR PUR EVO 1000 m³/h

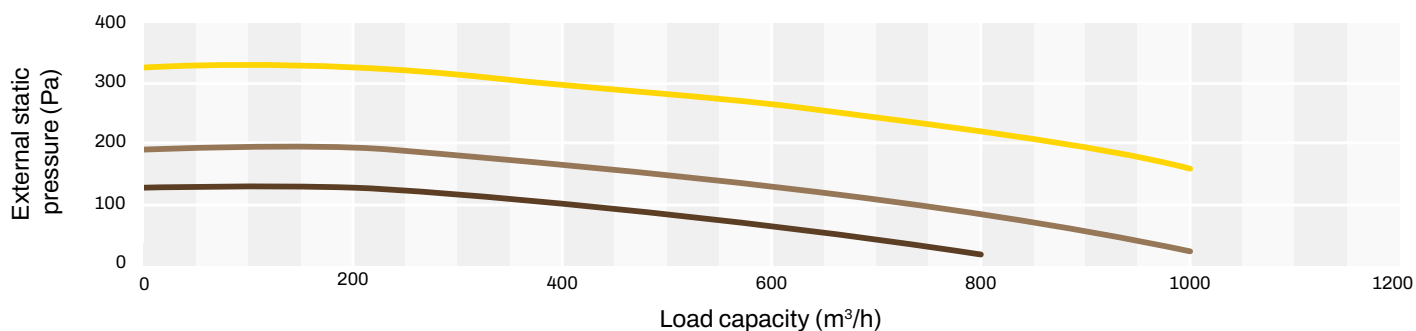

AIR PUR EVO 1700 m³/h

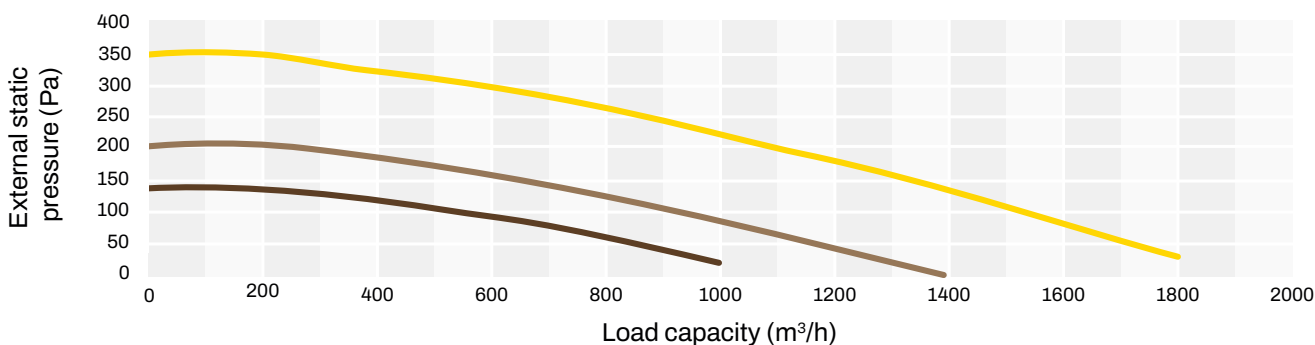

AIR PUR EVO 2500 m³/h

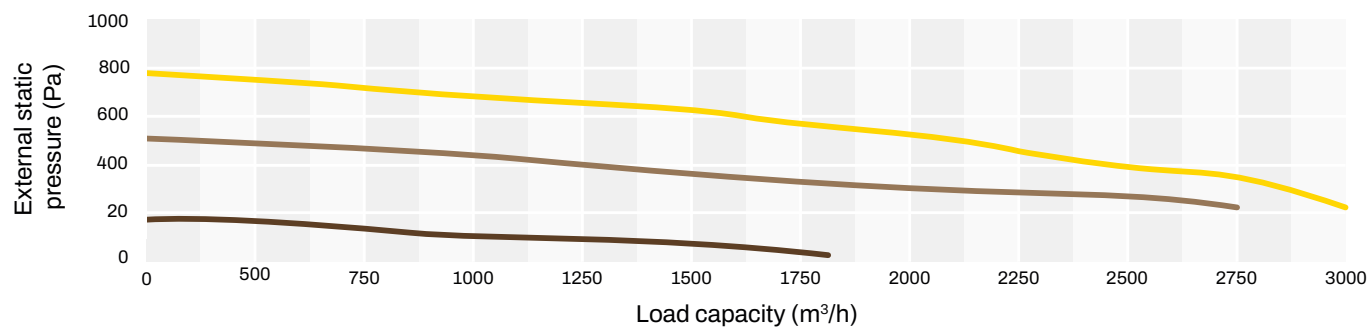

AIR PUR EVO 4000 m³/h

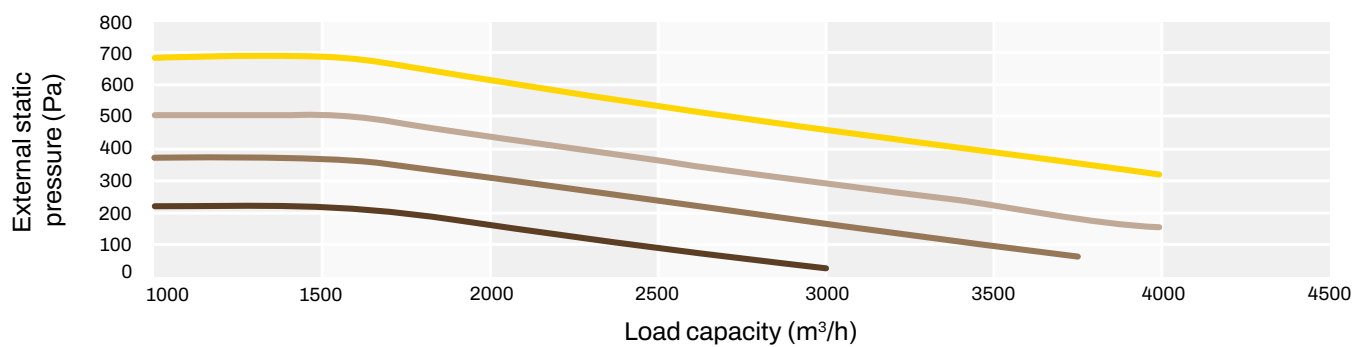

TOTAL AIR 200V - 300V - 500V EVO PLUS



STATIC WALL DUCTABLE HEAT RECOVERY UNIT WITH HIGH EFFICIENCY

TECHNICAL SPECIFICATIONS

- Class (sec): B
- Declared type: Bidirectional UVR
- Activation type installed: speed regulator
- High-efficiency cross-flow polypropylene heat exchanger
- Thermal efficiency of heat recovery: 85%
- Removable grade F7 filters

RÉCUPÉRATEUR DE CHALEUR STATIQUE GAINABLE VERTICAL À RENDEMENT ÉLEVÉ

CARACTÉRISTIQUES TECHNIQUES

- Classe (sec) : B
- Type déclaré : UVR bidirectionnel
- Type d'entraînement installé : variateur de vitesse
- Échangeur de chaleur en polypropylène à flux transversal à haute efficacité
- Efficacité thermique de la récupération de chaleur : 85 %
- Filtres amovibles grade F7

KANALISIERBARE WÄRMERÜCKGEWINNUNGSEINHEIT MIT HOHER VERTIKALEFFIZIENZ FÜR TRAGWÄNDE

TECHNISCHE EIGENSCHAFTEN

- Klasse (Sek.): B
- Deklarierter Typ: Bidirektionaler UVR
- Installierte Antriebsart: Drehzahlregler
- Hocheffizienter Kreuzstrom-Polypropylen-Wärmetauscher
- Wärmeeffizienz der Wärmerückgewinnung: 85%
- Herausnehmbare Filter, Grad F7

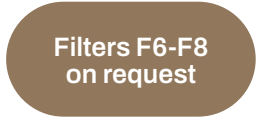
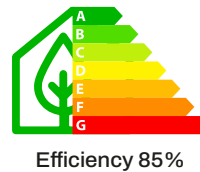
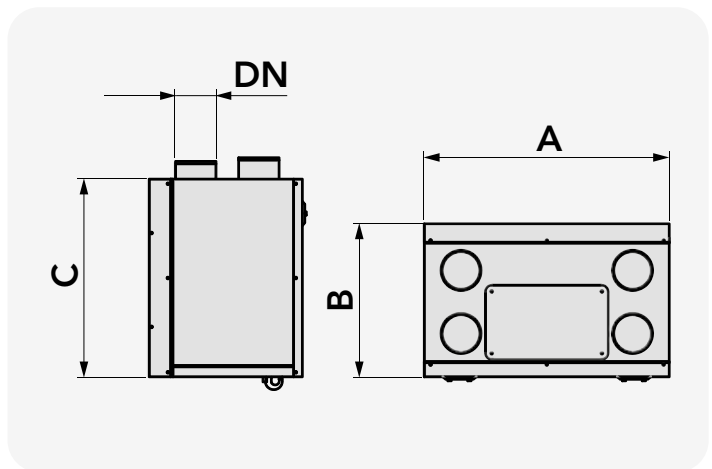

TECHNICAL SPECIFICATIONS	TOTAL AIR 200V	TOTAL AIR 300V	TOTAL AIR 500V
SUPPLY VOLTAGE [V]	230	230	230
FREQUENCY [HZ]	50	50	50
POWER CONSUMPTION [W]	170	170	340
SOUND LEVEL 3 M [DB(A)]	41	38,4	44,4
AIR FLOW RATE [M³/H]	306	375	475

MODEL	DIMENSIONS [mm]			
	A	B	C	DN
"TOTAL AIR 300V EVO PLUS" VERTICAL HEAT RECOVERY UNIT	790	640	670	160
"TOTAL AIR 400V EVO PLUS" VERTICAL HEAT RECOVERY UNIT	790	770	670	160
"TOTAL AIR 500V EVO PLUS" VERTICAL HEAT RECOVERY UNIT	790	770	670	160



TOTAL AIR 200 EVO PLUS

AERAULIC PERFORMANCE

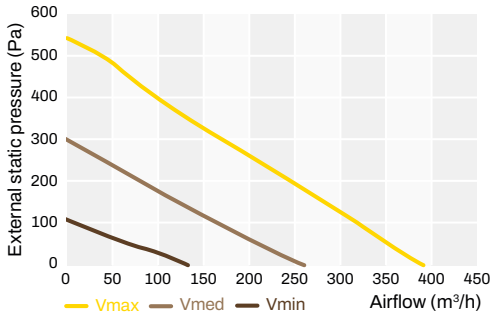

THERMAL EFFICIENCY

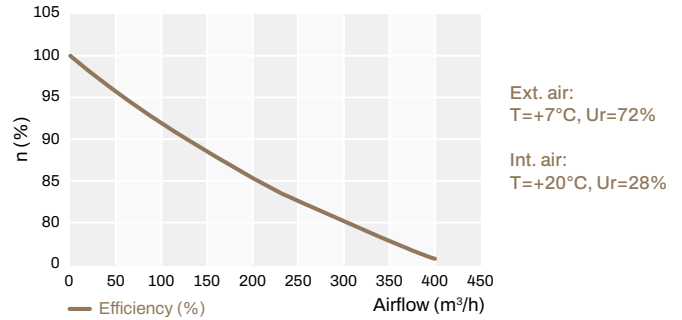

TOTAL AIR 300 EVO PLUS

AERAULIC PERFORMANCE

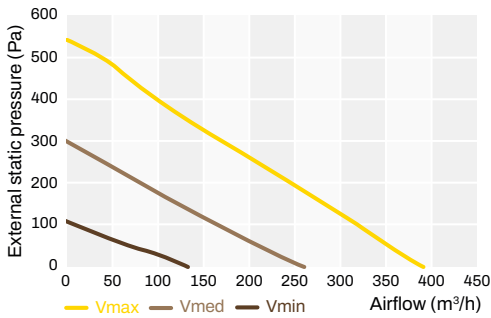

THERMAL EFFICIENCY

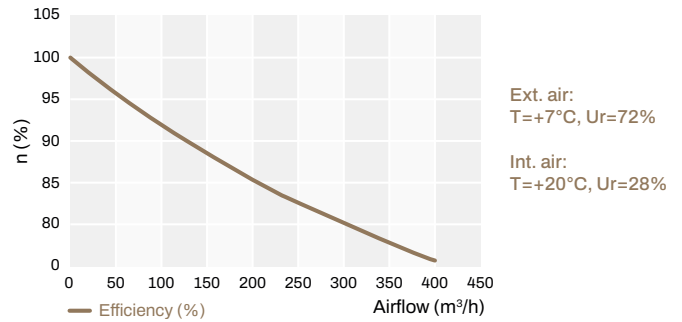

TOTAL AIR 500 EVO PLUS

AERAULIC PERFORMANCE

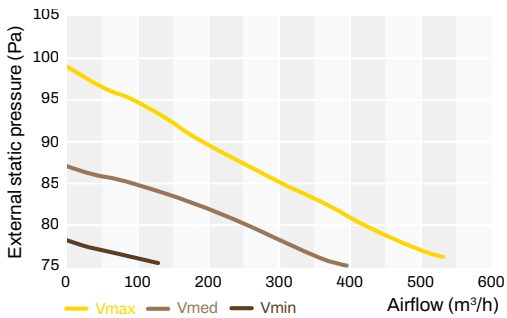

THERMAL EFFICIENCY

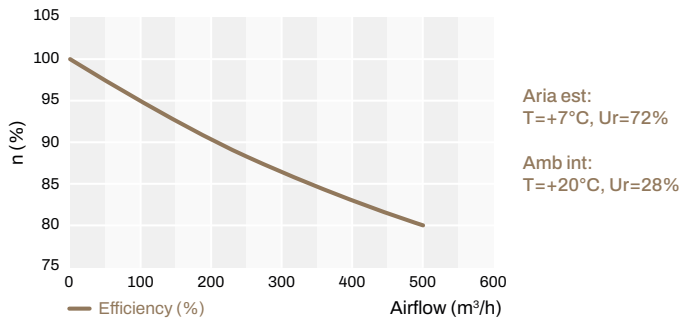

CODE	DESCRIPTION	U.M.	Pieces per box
12501000	"TOTAL AIR 300V EVO PLUS" VERTICAL HEAT RECOVERY UNIT	PCS	1
12501010	"TOTAL AIR 400V EVO PLUS" VERTICAL HEAT RECOVERY UNIT	PCS	1
12501020	"TOTAL AIR 500V EVO PLUS" VERTICAL HEAT RECOVERY UNIT	PCS	1

ENTHALPIC HEAT RECOVERY UNIT CEILING-MOUNTED DUCTED

TECHNICAL SPECIFICATIONS

- For residential and non-residential applications
- Removable enthalpy heat exchanger pack
- Automatic by-pass
- Brushless EC motors
- Internal structure in EPS that prevents condensation and improves thermal insulation
- Backlit LCD digital remote control
- BMS compatible VIA RS485 modbus protocol
- ON/OFF remote control
- Silent function "sleep"
- Defrost Function

RÉCUPÉRATEUR DE CHALEUR ENTHALPIQUE GAINABLE

CARACTÉRISTIQUES TECHNIQUES

- Pour applications résidentiels et non résidentiels
- Pack d'échange enthalpique amovible
- By-pass automatique
- Moteurs Brushless EC
- Structure interne en EPS qui prévient la formation de condensation et améliore l'isolation thermique
- Télécommande numérique LCD rétroéclairée
- Compatible BMS VIA RS485 protocole modbus
- Commande à distance ON/OFF
- Fonction silencieuse "sleep"
- Fonction defrost

ENTHALPISCH-WÄRMERÜCKGEWINNUNGSGERÄT KANN AN DIE DECKE GELEITET UND KANALISIERT WERDEN

TECHNISCHE EIGENSCHAFTEN

- Für Anwendungen im Wohn- und Gewerbebereich
- Abnehmbares Enthalpisches Austauschpaket
- Automatischer By-Pass
- Brushless EC Motoren
- Interne Struktur aus EPS, die der Kondensatbildung vorbeugt und die Wärmeisolierung verbessert
- Digitale LCD-Fernbedienung mit Hintergrundbeleuchtung
- Kompatibel BMS VIA RS485 Modbus-Protokoll
- Fernbedienung ON/OFF
- Leise "sleep" Funktion
- Auftaufunktion



Digital remote control



Can be integrated with
BMS SYSTEMS
(building automation)

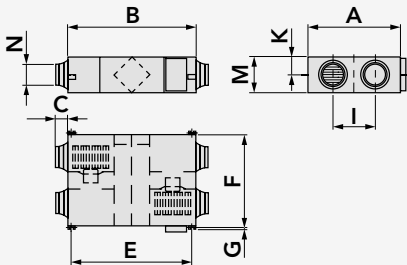

MOD.	DIMENSIONS [mm]									
	A	B	C	E	F	G	I	K	M	N
ACD300002	599	814	100	745	657	19	315	111	270	Ø 144

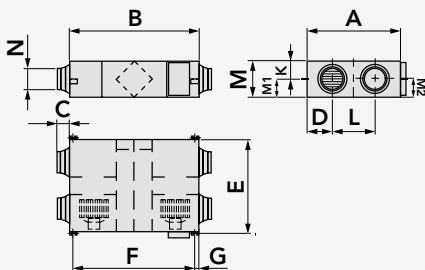

MOD.	DIMENSIONS [mm]												
	A	B	C	D	E	F	G	L	K	M	M1	M2	N
ACD300003	902	867	107	197	833.5	922	20.5	451.5	115.5	280	193.5	-	Ø 194
ACD300004	1134	1134	85	202	1068	1189	20.5	628	128	388	194	-	Ø 242
ACD300005	1243	1193	85	241	1173	1248	20.5	629.5	133	388	191	241	Ø 242
ACD300006	1243	1193	85	241	1173	1248	20.5	629.5	133	388	191	241	Ø 242

CODE	DESCRIPTION	U.M.	 Pieces per box
ACD300002	ENTHALPIC HEAT RECOVERY UNIT - Model HI-TECH PUR 4.0 250m3/h	PCS	1
ACD300003	ENTHALPIC HEAT RECOVERY UNIT - Model HI-TECH PUR 4.0 500m3/h	PCS	1
ACD300004	ENTHALPIC HEAT RECOVERY UNIT - Model HI-TECH PUR 4.0 800m3/h	PCS	1
ACD300005	ENTHALPIC HEAT RECOVERY UNIT - Model HI-TECH PUR 4.0 1000m3/h	PCS	1
ACD300006	ENTHALPIC HEAT RECOVERY UNIT - Model HI-TECH PUR 4.0 1300m3/h	PCS	1

Datasheet



ENTHALPY HEAT RECOVERY UNIT FLOW RATE AND EFFICIENCY GRAPHS

PERFORMANCE CURVES ACD300002

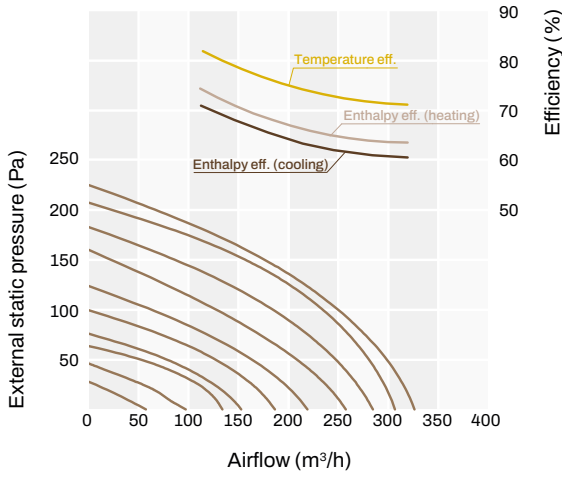

PERFORMANCE CURVES ACD300003

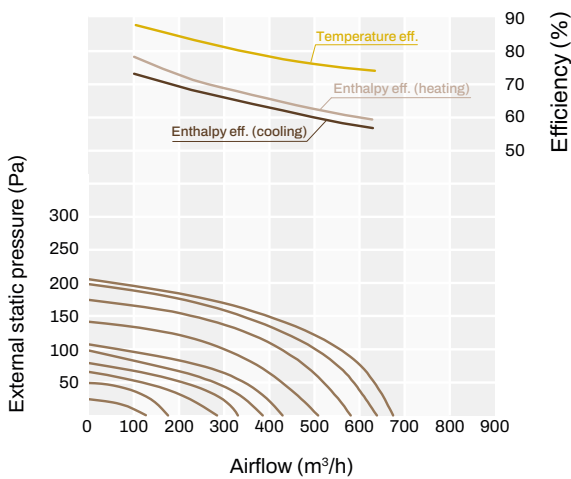

PERFORMANCE CURVES ACD300003

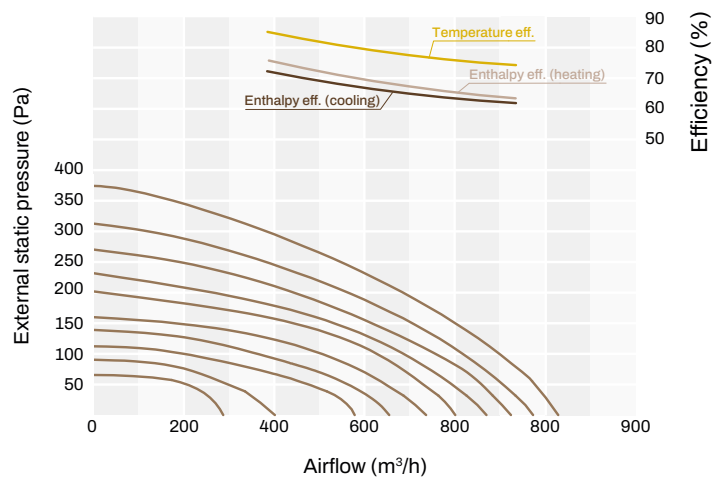

PERFORMANCE CURVES ACD300005

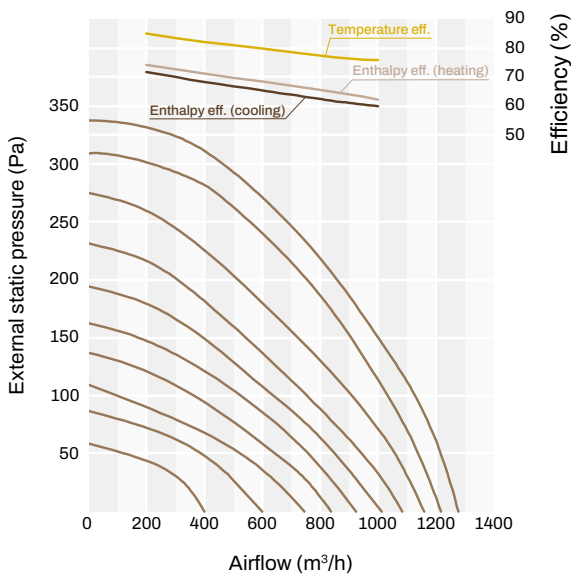

PERFORMANCE CURVES ACD300006

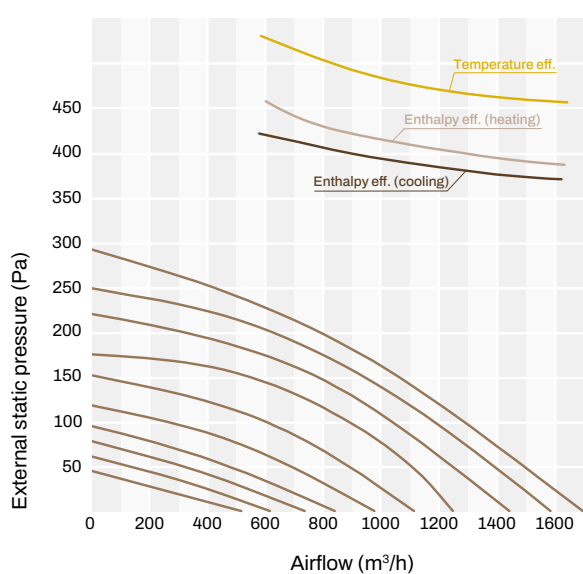

ELECTRICAL AND PERFORMANCE DATA						
MODEL		ACD300002	ACD300003	ACD300004	ACD300005	ACD300006
FLOW RATE [M ³ /H]		250	500	800	1000	1300
FLOW RATE [L/S]		70	139	222	278	361
EXTERNAL PRESSURE [PA]		100	120	150	150	90
ENTHALPY EFF. (%)	COOLING	62-71	60-74	63-71	60-70	56-68
	HEATING	65-73	63-78	65-75	62-72	59-70
TEMP. EFFICIENCY [%]		73	76	76	76	73
NOISE [DB(A)]		34.5	39	42	43	43
POWER SUPPLY		220-240 V - 50 Hz -1 Ph				
ELECTRICAL POWER [W]		80	230	368	409	424
POWER CABLE [MM ²]		3x1,5 mm ²				
CONTROL CABLE [MM ²]		2x0,5 mm ²				
CONTROL	STANDARD	yes (weekly clock)				
	(BMS) MODBUS	yes				
FAN TYPE		Brushless DC motor				
FAN SPEED		10-speed control				
SUMMER BYPASS		yes (automatic with adjustable flow rate)				
FAN BOOST		yes (1x connections available to voltage-free contacts: closed = switch to maximum speed)				
FIRE STOP		yes (1x connections available to voltage-free contacts: closed = power off)				
WEIGHT [KG]		25	34	61	71	71
DUCT DIAMETER [MM]		144	194	242	242	242

ERP DATA						
MODEL		ACD300002	ACD300003	ACD300004	ACD300005	ACD300006
BRAND		Tecnosystemi				
TYPE		UVNR/UVB - Non-residential ventilation unit, bidirectional				
DRIVE TYPE		with 10 speeds				
TYPE OF HRS		Recovery				
THERMAL EFFICIENCY OF HEAT RECOVERY	%	73	76	76	76	83
NOMINAL FLOW RATE	m ³ /s	0.069	0.139	0.222	0.278	0.361
ELECTRICAL POWER INPUT	kW	0.08	0.23	0.368	0.409	0.424
SFPINT	W/(m ³ /s)	152	191	166	184	212
FRONTAL SPEED AT DESIGN FLOW RATE	m/s	1.22	1.5	1.26	1.42	1.7
NOMINAL EXTERNAL PRESSURE (Δ PS, EXT)	Pa	100	120	150	150	90
INTERNAL PRESSURE DROP OF VENTILATION COMPONENTS (Δ PS, INT)	Pa	88	111	93	107	110
FAN STATIC EFFICIENCY WHEN USED AS PER REGULATION (EU) NO. 327/2011	%	58	58	56	58	58
MAXIMUM EXTERNAL LEAKAGE RATE	%	3	3	3	3	3
MAXIMUM DECLARED EXTERNAL LEAKAGE RATE	%	7.8	7.7	7.8	7.8	7.8
ENERGY CLASSIFICATION OF FILTERS		C	C	C	C	C
DESCRIPTION OF VISUAL FILTER WARNING SIGNAL		pressure control				
SOUND POWER LEVEL AT BODY (LWA)	dB(A)	34.5	39	42	43	43
WEBSITE		www.tecnosystemi.com				

DEHUMIDIFIER FOR DUCTABLE CEILING

TECHNICAL SPECIFICATIONS

- For interior ceiling installations
- Features a larger fan
- Removable filter
- Adjustable air outlet temperature
- 2 modes: dehumidifier and ventilation

DÉSHUMIDIFICATEUR GAINABLE

CARACTÉRISTIQUES TECHNIQUES

- Pour les installations de plafond intérieur
- Dispose d'un ventilateur agrandi
- Filtre amovible
- Température de sortie d'air réglable
- 2 modes : déshumidificateur et ventilation

FÜR ZWISCHENDECKEN LUF-TENTFEUCHTER

TECHNISCHE EIGENSCHAFTEN

- Für interne Montage an Zwischendecke
- Mit größerem Ventilator
- Abnehmbarer Filter
- Einstellbare Luftaustrittstemperatur
- 2 Modi: Luftentfeuchter und Lüftung

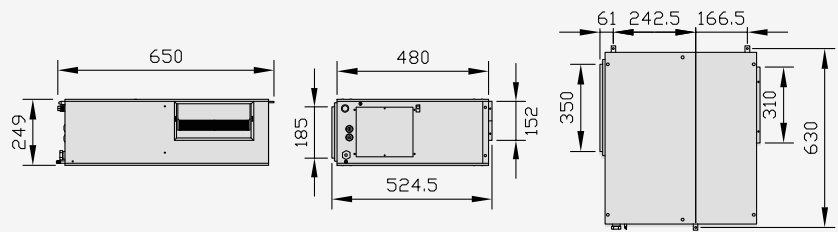

Available on request

CODE	DESCRIPTION	U.M.	Pieces per box	DIMENSIONS OF UNIT [mm]	
				HEIGHT	WIDTH
30200010	FALSE-CEILING-DUCTED DEHUMIDIFIER UNIT "DE.CS25"	PCS	1	249	525
				650	

TECHNICAL DATA		TECHNICAL DATA	
CONDENSING HUMIDITY (26° - 65%) [l/day]	24	AIR FLOW RATE [m³/h]	250
POWER CONSUMPTION [W]	290	MAX. HEAD (VEL.3) [Pa]	60
POWER SUPPLY V/Ph/Hz	230/1/50	MEAN HEAD (VEL.2) [Pa]	40
MAX POWER ABSORBED [W]	340	LOW HEAD (VEL.1) [Pa]	10
WATER FLOW RATE (15°C) [l/h]	240	REFRIGERANT (R290) [GR]	70
CHILLER POWER CONSUMPTION [W]	830	SOUND POWER LEVEL [dB(A)]	41
LOAD LOSS [kPa]	5	SOUND PRESSURE LEVEL [DB(A)]	33



DE.CS25 PLENUM

MADE IN ITALY

PLENUM FOR DUCTABLE CEILING DEHUMIDIFIER

TECHNICAL SPECIFICATIONS

- No. of pre-drilled holes: 1 front + 2 sides
- Ø Holes: 150mm
- Depth: 250mm
- Plenum for collar model A1
- Intake plenum available on request.

PLÉNUM POUR DÉSHUMIDIFICATEUR GAINABLE

CARACTÉRISTIQUES TECHNIQUES

- Nombre de trous pré-perçés : 1 devant + 2 latéraux
- Trou Ø : 150 mm
- Profondeur : 250 mm
- Plénum pour collier modèle A1
- Disponible sur demande plénum pour la récupération.

PLENUM FÜR KANALISIERBARE-LUFTENTFEUCHTER FÜR ZWISCHENDECKEN

TECHNISCHE EIGENSCHAFTEN

- Anzahl der vorgestanzten Bohrungen: 1 Vorderseite + 2 Seiten
- Ø Löcher: 150 mm
- Tiefe: 250 mm
- Plenum für Schellenmodell A1
- Ansaugplenum auf Anfrage erhältlich.



Datasheet



CODE	DESCRIPTION	U.M.	Pieces per box
11161601	PLENUM FOR DUCTABLE DEHUMIDIFIER	PCS	1

**BACTERICIDAL
SANITISING LAMP**

IDEAL FOR

- Installation in new and existing systems
- Residential, commercial, industrial VMC systems
- Residential, commercial, industrial HVAC systems
- Air conditioning systems
- Ventilation systems
- Air handling unit (AHU)
- Distribution or air connection plenum
- Air distribution duct

**LAMPE DÉSINFECTANTE
BACTÉRIQUE**

IDÉAL POUR

- Installation dans les systèmes neufs et existants
- Systèmes VMC résidentiels, commerciaux, industriels
- Systèmes HVAC résidentiels, commerciaux, industriels
- Systèmes de climatisation
- Systèmes de ventilation
- Unité de traitement d'air (UTA)
- Plénum de distribution ou de raccordement d'air
- Conduit de distribution air

**BAKTERIZIDE
DESINFIZIERSLAMPE**

IDEAL FÜR

- Installation in neue und bestehende Systeme
- Wohn-, Gewerbe-, Industrie-VMC-Systeme
- Wohn-, Gewerbe-, Industrieklimaanlagen
- Klimaanlage
- Lüftungssysteme
- Luftbehandlungseinheit (LBE)
- Verteiler - Plenum oder Luftverschraubung
- Luftverteilungskanal



ACC600094
da 1.000 - 1.500 m³/h

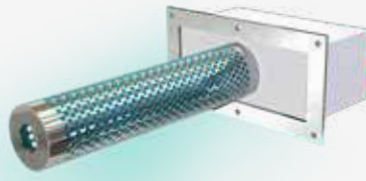

ACC600095
da 2.500 - 3.000 m³/h



ACC600096
da 1.500 - 2.500 m³/h

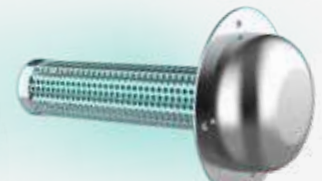

ACC600097
da 3.000 - 11.000 m³/h

PHOTOCATALYTIC PROCESS

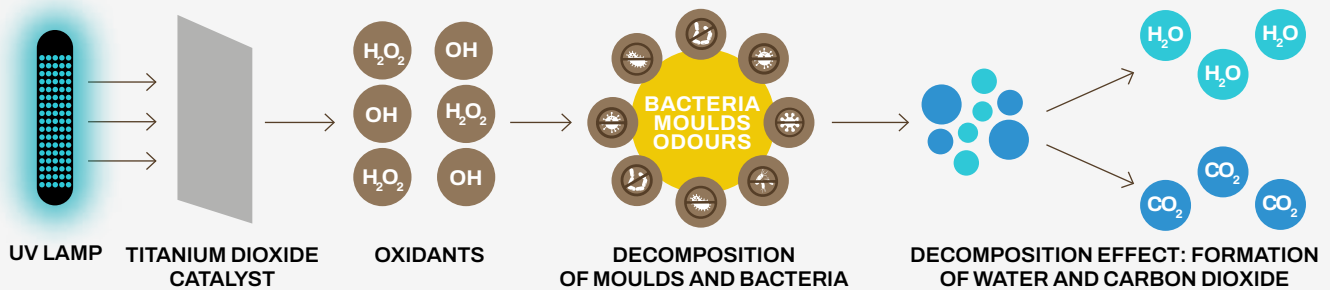

Datasheet



Datasheet



Datasheet



Datasheet



MODEL	ACC600094	ACC600095	ACC600096	ACC600097
VOLTAGE [V]	230	230	230	230
FREQUENCY [Hz]	50	50	50	50
ABSORBED POWER [W]	6	10	15	13,3
TECHNOLOGY	PHOTOCATALYST	PHOTOCATALYST	PHOTOCATALYST	PHOTOCATALYST
OPERATING RANGE m³/h	1.000 - 1.500	1.500 - 2.500	2.500 - 3.000	3.000 - 11.000
DIMENSIONS [mm]	L 170 x H 85 x D 235	170 x H 85 x D 295	L 165 x H 145 x D 385	Ø External 140 Ø Internal 50 - L total 230

CODE	DESCRIPTION	U.M.	Pieces per box
ACC600094	XHP15 HVAC BACTERICIDAL SANITISING LAMP WITH PHOTOINITIATOR	PCS	1
ACC600095	XHP25 HVAC BACTERICIDAL SANITISING LAMP WITH PHOTOINITIATOR	PCS	1
ACC600096	XHP30 HVAC BACTERICIDAL SANITISING LAMP WITH PHOTOINITIATOR	PCS	1
ACC600097	XHP110 BACTERICIDAL SANITISING LAMP WITH XHP110 PHOTOINITIATOR	PCS	1



HEATING BATTERY HOT/ COLD

TECHNICAL SPECIFICATIONS

- Self-supporting structure in pre-painted metal sheet
- Thermal/acoustic insulation in expanded polyethylene sp. 10 mm
- Inlet/Outlet Sleeve To Fix Air-Side Ducting
- Condensate water collection tray
- Configuration with H2O connections on the right side (following the air flow)
- Fastening brackets supplied

BATTERIE CHAUFFANTE CHAUDE/FROIDE

CARACTÉRISTIQUES TECHNIQUES

- Structure autoportante en tôle pré-peinte
- Isolation thermique/acoustique en polyéthylène expansé sp. 10 mm
- Manchon En Entrée/Sortie Pour La Fixation Des Canalisations Côté Air
- Bac à condensation
- Configuration avec raccords H2O sur le côté droit (en suivant le flux d'air)
- Supports de fixation fournis

HEIZBATTERIE HEISS/ KALT

TECHNISCHE EIGENSCHAFTEN

- Selbsttragende Struktur aus vorlackiertem Metallblech
- Wärme-/Schalldämmung aus geschäumtem Polyethylen st. 10 mm
- Ein-/Auslass Muffe zur Luftkanale Befestigung
- Auffangschale für Kondenswasser
- Konfiguration mit H2O-Anschluss auf der rechten Seite (dem Luftstrom folgend)
- Befestigungsbügel mitgeliefert

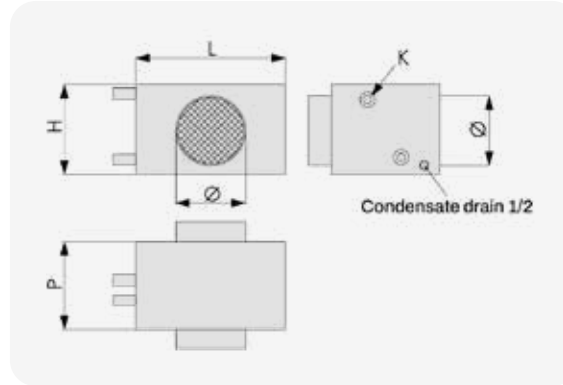

HEATING

CODE		ACC400017	ACC400018	ACC400019	ACC400020	ACC400021	ACC400022	ACC400023	ACC400024	ACC400025	ACC400026
AIR FLOW RATE	[m³/h]	150	220	350	500	800	1200	1600	2200	3200	4000
	[m/s]	1.2	1	1.6	1.6	1.4	1.45	1.61	2.22	2.21	2.14
T° IN WATER	[°C]	50	50	50	50	50	50	50	50	50	50
T° OUT WATER	[°C]	45	45	45	45	45	45	45	45	45	45
TOTAL POWER	[W]	1	1.6	2.2	3.2	5.7	10	12.9	18.7	27.4	34.5
T° IN AIR	[°C]	20	20	20	20	20	20	20	20	20	20
T° OUT AIR	[°C]	40.6	41.6	38.9	38.7	41	44.7	43.9	45.2	45.4	45.6
WATER FLOW RATE	[l/h]	181	279	389	549	985	1728	2234	3241	4747	5988
	[m/s]	1	0.8	1.1	1	1	1.25	1.08	1.17	1.37	1.44
WATER PRESSURE DROP	[kPa]	20.4	10.3	18.4	13.4	11.9	21.5	14.4	15.4	21.2	26.3
AIR PRESSURE DROP	[Pa]	8	6	13	14	13	27	33	75	74	70

COOLING

T° IN WATER	[°C]	7	7	7	7	7	7	7	7	7	7
T° OUT WATER	[°C]	12	12	12	12	12	12	12	12	12	12
TOTAL POWER	[kW]	1	1.6	2.2	3.1	5.7	7.8	9.7	15.1	22.5	28.7
SENSITIVE POWER.	[kW]	0.6	0.9	1.2	1.7	3.1	4.9	6.2	9.2	13.7	17.2
T° IN AIR	[°C]	27	27	27	27	27	27	27	27	27	27
RH% IN AIR	[%rH]	60	60	60	60	60	60	60	60	60	60
T° OUT AIR	[°C]	15.2	14.9	16.4	16.7	15.1	15.1	15.6	14.6	14.5	14.3
RH% OUT AIR	[%rH]	87.3	89.2	85	84.9	88.1	99.8	99.4	100	100	100
WATER FLOW RATE	[l/h]	183	272	380	523	981	1334	1664	2601	3863	4929
	[m/s]	1	0.8	1	1	1	0.96	0.8	0.94	1.12	1.19
WATER PRESSURE DROP	[kPa]	25.5	12.2	21.8	15.1	14.5	15.9	10	15.5	20	21.8
AIR PRESSURE DROP	[Pa]	12	9	19	20	20	54	63	113	113	108
CONDENSATE	[l/h]	0.7	1.1	1.5	2.1	4	4	4.8	8.2	12.3	15.9

CODE	DESCRIPTION	L [mm]	H [mm]	P [mm]	Ø [mm]	K [inch]	U.M.	Pieces per box
ACC400017	COLD / HOT WATER COIL - 150m³/h e 1Kw	310	200	300	125	1/2"	PCS	1
ACC400018	COLD / HOT WATER COIL - 220m³/h e 1,6Kw	360	270	300	160	1/2"	PCS	1
ACC400019	COLD / HOT WATER COIL - 350m³/h e 2,2Kw	360	270	300	160	1/2"	PCS	1
ACC400020	COLD / HOT WATER COIL - 500m³/h e 3,2Kw	460	270	300	200	1/2"	PCS	1
ACC400021	COLD / HOT WATER COIL - 800m³/h e 5,7Kw	650	330	300	250	1/2"	PCS	1
ACC400022	COLD / HOT WATER COIL - 1200m³/h e 7,8Kw	785	430	350	315	3/4"	PCS	1
ACC400023	COLD / HOT WATER COIL - 1600m³/h e 9,7Kw	780	520	350	315	3/4"	PCS	1
ACC400024	COLD / HOT WATER COIL - 2200m³/h e 15Kw	780	520	400	355	3/4"	PCS	1
ACC400025	COLD / HOT WATER COIL - 3200m³/h e 22Kw	895	660	450	400	1"	PCS	1
ACC400026	COLD / HOT WATER COIL - 4000m³/h e 29Kw	1000	740	450	400	1"	PCS	1

Datasheet



HOT WATER BATTERY FOR HEAT RECOVERY UNIT

TECHNICAL SPECIFICATIONS

- To be used indoors with ambient temperature between +1 and +50°C
- Max temperature: +100°C
- Maximum pressure at +100°C: 16 MPa (16 bar)
- Designed for cold weather and temperature zones
- Copper hoses, aluminium finned pack
- Galvanized steel case

BATTERIE À EAU CHAUDE POUR RÉCUPÉRATEUR DE CHALEUR

CARACTÉRISTIQUES TECHNIQUES

- À utiliser à l'intérieur à une température ambiante comprise entre +1 et +50 °C
- Température maximale : +100°C
- Pression maximale à +100°C : 16 MPa (16 bar)
- Ils sont conçus pour les zones à climats et températures froids
- Tuyaux en cuivre, paquet à ailettes en aluminium
- Boîtier en acier galvanisé

WARMWASSERHEIZREGISTER FÜR WÄRMERÜCKGEWINNUNGSSYSTEME

TECHNISCHE EIGENSCHAFTEN

- Zur Verwendung in Innenräumen mit einer Umgebungstemperatur zwischen +1 und +50 °C
- Max. Temperatur: +100°C
- Maximaler Druck bei +100°C: 16 MPa (16 bar)
- Für Gebiete mit kaltem Klima und kalten Temperaturen geeignet
- Kupferrohre, Packung mit Aluminiumrippen
- Gehäuse aus verzinktem Stahl

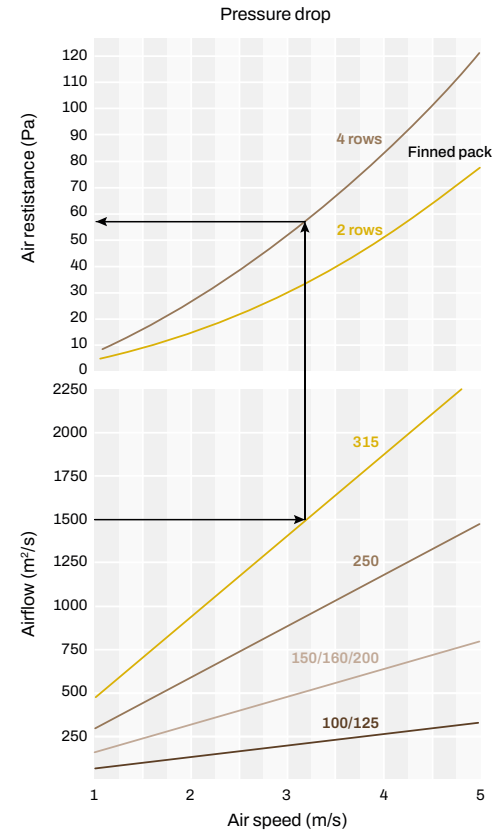
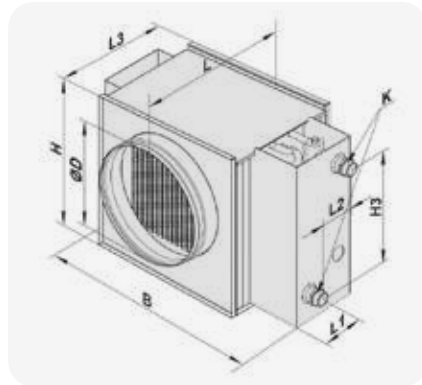
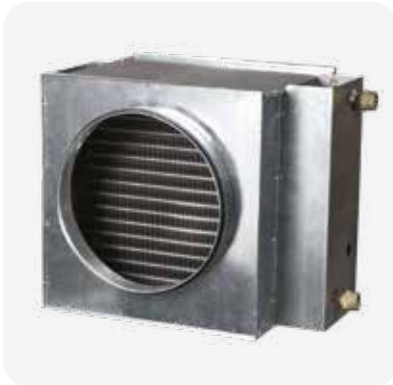

Connection with the **opposite** direction of the airflow

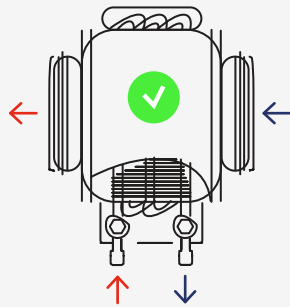

Connection with the **same** direction of the airflow

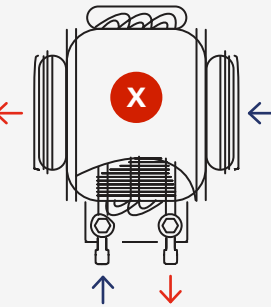

Allow the air temperature to increase, thereby assisting the fill packs

MOD.	Ø D [mm]	B [mm]	H [mm]	H3 [mm]	L[mm]	L1 [mm]	L2 [mm]	L3 [mm]	K [mm]	N° BATTERIES ARRAY	WEIGHT [kg]
200 - 2	198	400	280	200	300	32	43	220	G 3/4"	2	7,5
200 - 4	198	400	280	200	300	28	65	220	G 3/4"	4	8,2
250 - 2	248	470	350	270	350	32	43	270	G 1"	2	10,3
250 - 4	248	470	350	270	350	28	65	270	G 1"	4	10,8
315 - 2	313	550	430	350	450	57	43	370	G 1"	2	12,6
315 - 4	313	550	430	350	450	53	65	370	G 1"	4	13,4

CODE	DESCRIPTION	U.M.	Pieces per box
30370025	HOT WATER COIL FOR HEAT-RECOVERY UNITS 200-2	PCS	1
30370030	HOT WATER COIL FOR HEAT-RECOVERY UNITS 200-4	PCS	1
30370035	HOT WATER COIL FOR HEAT-RECOVERY UNITS 250-2	PCS	1
30370040	HOT WATER COIL FOR HEAT-RECOVERY UNITS 250-4	PCS	1
30370045	HOT WATER COIL FOR HEAT-RECOVERY UNITS 315-2	PCS	1
30370050	HOT WATER COIL FOR HEAT-RECOVERY UNITS 315-4	PCS	1

Datasheet





ELECTRICAL BATTERY WITH THERMOSTAT FOR HEAT RECOVERY FROM 200 TO 800 M³/H

TECHNICAL SPECIFICATIONS

- Equipped with thermostat for temperature regulation from -10°C to +40°C
- Equipped with two thermoprotectors: +50°C with automatic reset; +90°C with manual reset
- To prevent overheating the battery, air flow must always be greater than the minimum flow rate indicated in the table



BATTERIE ÉLECTRIQUE AVEC THERMOSTAT POUR RÉCUPÉRATEUR DE CHALEUR DE 200 À 800 M³/H

CARACTÉRISTIQUES TECHNIQUES

- Équipé d'un thermostat pour la régulation de température de -10 °C à + 40 °C
- Équipé de deux protecteurs thermiques : +50°C avec réinitialisation automatique ; +90°C avec réinitialisation manuelle
- Pour éviter une surchauffe de la batterie, le débit d'air doit toujours être supérieur au débit minimum indiqué dans le tableau



ELEKTRISCHES HEIZREGIST-STER MIT THERMOSTAT ZUR WÄRMERÜCKGEWINNUNG VON 200 BIS 800 M³/H

TECHNISCHE EIGENSCHAFTEN

- Mit Thermostat für Temperaturregelung von -10 °C bis + 40 °C
- Mit zwei Wärmeschutzvorrichtungen: +50°C mit automatischem Reset; +90°C mit manuellem Reset
- Um eine Überhitzung der Batterie zu vermeiden, muss der Luftstrom immer größer als der in der Tabelle angegebene Mindestluftstrom sein



Double thermal protector

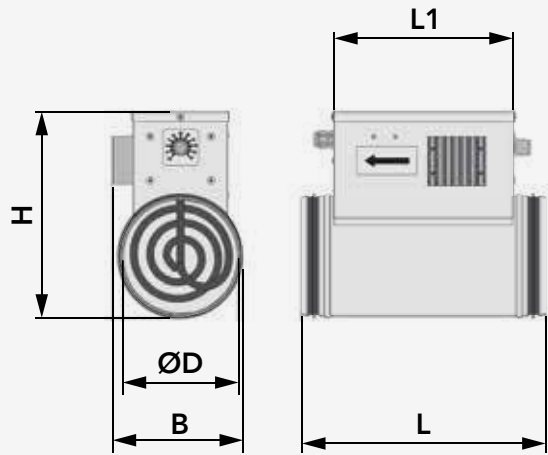

Supplied with thermostat for heat regulation from -10°C TO +40°C

MODEL	NOMINAL FLOW RATE [M ³ /H]	MINIMUM FLOW RATE [M ³ /H]	ΔT NOMINAL AIR [°C]	COUPLERS [MM]	VOLTAGE [V]	FREQUENCY [Hz]	POWER [KW]	WEIGHT [kg]	L [mm]	H [mm]	B [mm]	L1 [mm]
125 - 0,6	200	60	9	125	230	50	0,6	1,6	306	230	103	227
150 - 1,2	300	120	12	150	230	50	1,2	2,1	306	144	226	226
200 - 1,7	500	150	7	200	230	50	1,7	2,6	306	302	174	228
200 - 2,4	800	180	9	200	230	50	2,4	3,2	376	302	174	298

CODE	DESCRIPTION	U.M.	Pieces per box
ACC400001	ELECTRICAL BATTERIES WITH THERMOSTAT Ø125 0,6 kW FOR HEAT RECOVERY UNITS	PCS	1
ACC400002	ELECTRICAL BATTERIES WITH THERMOSTAT Ø150 1,2 kW FOR HEAT RECOVERY UNITS	PCS	1
ACC400003	ELECTRICAL BATTERIES WITH THERMOSTAT Ø200 1,7 kW FOR HEAT RECOVERY UNITS	PCS	1
ACC400004	ELECTRICAL BATTERIES WITH THERMOSTAT Ø200 2,4 kW FOR HEAT RECOVERY UNITS	PCS	1

[Datasheet](#)



ELECTRICAL BATTERY WITH THERMOSTAT FOR HEAT RECOVERY FROM 1000 TO 4000 M³/H

TECHNICAL SPECIFICATIONS

- Equipped with thermostat for temperature regulation from -30°C +30°C
- Equipped with two thermoprotectors: +55°C with automatic reset +85°C with manual reset
- To prevent overheating the battery, air flow must always be greater than the minimum flow rate indicated in the table

BATTERIE ÉLECTRIQUE AVEC THERMOSTAT POUR RÉCUPÉRATEUR DE CHALEUR DE 1000 À 4000 M³/H

CARACTÉRISTIQUES TECHNIQUES

- Équipé d'un thermostat pour la régulation de température de -30 °C à +30 °C
- Équipé de deux protecteurs thermiques : +55°C avec réinitialisation automatique +85°C avec réinitialisation manuelle
- Pour éviter une surchauffe de la batterie, le débit d'air doit toujours être supérieur au débit minimum indiqué dans le tableau

ELEKTRISCHE HEIZREGISTER MIT THERMOSTAT ZUR WÄRMERÜCKGEWINNUNG VON 1000 BIS 4000 M³/H

TECHNISCHE EIGENSCHAFTEN

- mit Thermostat für Temperaturregelung von -30 °C bis +30 °C
- Mit zwei Wärmeschutzvorrichtungen: +55°C mit automatischem Reset +85°C mit manuellem Reset
- Um eine Überhitzung der Batterie zu vermeiden, muss der Luftstrom immer größer als der in der Tabelle angegebene Mindestluftstrom sein

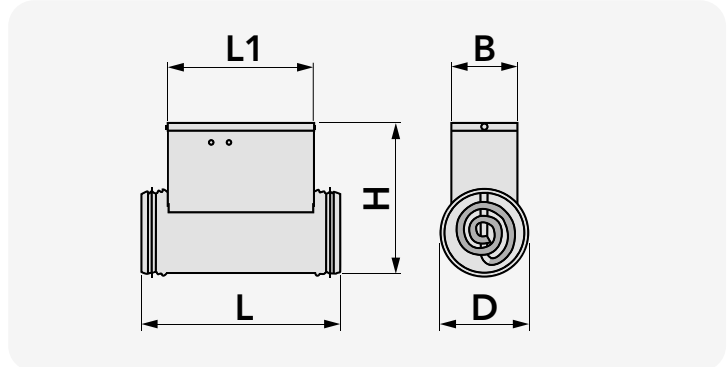

MODEL	NOMINAL FLOW RATE [M ³ /H]	MINIMUM FLOW RATE [M ³ /H]	ΔT NOMINAL AIR [°C]	COUPLERS [MM]	VOLTA-GE [V]	FRE-QUENCY [Hz]	POWER [KW]	MODEL	L [mm]	H [mm]	B [mm]	L1 [mm]	WEIGHT [Kg]
315 - 3	1200	320	9,3	315	400	50	3	315-3	400	450	200	300	8,5
315 - 4	1600	430	9,3	315	400	50	4	315-4	400	450	200	300	8,5
355 - 6	2200	640	10,2	355	400	50	6	355-6	400	490	210	300	8,5
400 - 12	3200	1280	14	400	400	50	12	400-12	400	495	260	300	10
400 - 16	4000	1710	14,9	400	400	50	16	400-16	400	550	260	300	10

CODE	DESCRIPTION	U.M.	Pieces per box
ACC400005	ELECTRICAL BATTERIES WITH THERMOSTAT Ø315 3 kW FOR HEAT RECOVERY UNITS	PCS	1
ACC400006	ELECTRICAL BATTERIES WITH THERMOSTAT Ø315 4 kW FOR HEAT RECOVERY UNITS	PCS	1
ACC400007	ELECTRICAL BATTERIES WITH THERMOSTAT Ø355 6 kW FOR HEAT RECOVERY UNITS	PCS	1
ACC400008	ELECTRICAL BATTERIES WITH THERMOSTAT Ø400 12 kW FOR HEAT RECOVERY UNITS	PCS	1
ACC400009	ELECTRICAL BATTERIES WITH THERMOSTAT Ø450 16 kW FOR HEAT RECOVERY UNITS	PCS	1

Datasheet

COLD WATER BATTERY FOR HEAT RECOVERY UNIT

TECHNICAL SPECIFICATIONS

- Maximum operating pressure: 15 bar
- Horizontal installation only
- If the battery is installed in areas where the temperature is below 0°C, use an antifreeze mixture
- Designed for cooling the supply air in the ventilation system on rectangular ducting
- Heat exchanger with copper pipes and aluminium fin pack

BATTERIE À EAU FROIDE POUR RÉCUPÉRATEURS DE CHALEUR

CARACTÉRISTIQUES TECHNIQUES

- Pression maximale de fonctionnement : 15 bar
- Installation horizontale uniquement
- Si la batterie est installée dans des zones inférieures à 0 °C, utilisez un mélange antigel
- Conçu pour refroidir l'air d'alimentation dans le système de ventilation sur des canaux rectangulaires
- Pack d'échange avec tubes en cuivre et ailettes en aluminium

KALTWASSERBATTERIE FÜR WÄRMERÜCKGEWINNUNGSSYSTEME

TECHNISCHE EIGENSCHAFTEN

- Maximaler Betriebsdruck: 15 bar
- Nur horizontale Montage
- Wenn die Batterie in Bereichen mit einer Temperatur unter 0°C installiert wird, ein Frostschutzmittelgemisch verwenden
- Ausgelegt für die Kühlung der Zuluft in der Lüftungsanlage an rechteckigen Kanälen
- Austauschpaket mit Kupferrohren und Aluminiumrippen



Available on request

CODE	DESCRIPTION	U.M.	Pieces per box
30370070	COLD WATER COILS FOR. HEAT RECOVERY UNITS 400x200	PCS	1
30370080	COLD WATER COILS FOR. HEAT RECOVERY UNITS 500x250	PCS	1

Datasheet

UA30-90

 AMBIENT HUMIDIFIER SWITCH FOR DEHUMIDIFIER UA30-90

 COMMUTATEUR HUMIDIFICATEUR D'AMBIANCE POUR DÉSHUMIDIFICATEUR

 UMGEBUNGSBEFEUCHTERSCHALTER FÜR ENTFEUCHTER



CE

Available on request

[Datasheet](#)

CODE	DESCRIPTION	U.M.	Pieces per box
30200050	INDOOR HYGROSTAT FOR DEHUMIDIFIER "UA30-90"	PCS	1



 RIGID CIRCULAR SILENCER

 SILENCIEUX CIRCULAIRE RIGIDE

 STARRER RUNDSCHALLDÄMPFER

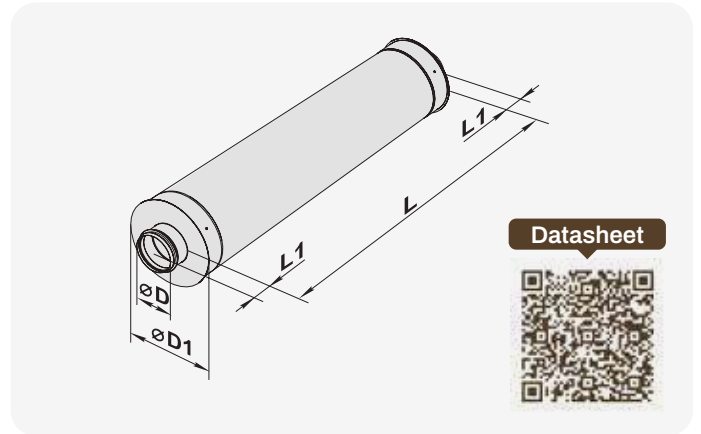

[Datasheet](#)



REDUCTION OF NOISE (dB)

RIGID CIRCULAR SILENCER

MODEL	63 [Hz]	125 [Hz]	250 [Hz]	500 [Hz]	1000 [Hz]	2000 [Hz]	4000 [Hz]	8000 [Hz]
100/900	5	10	15	23	44	30	16	15
125/900	4	9	12	22	43	22	16	12
150/900	3	5	9	18	36	25	13	14
160/900	2	5	10	19	37	25	13	15
200/900	3	7	11	20	39	23	8	7
250/900	4	5	7	16	32	20	12	10
315/900	3	5	7	17	30	14	10	8

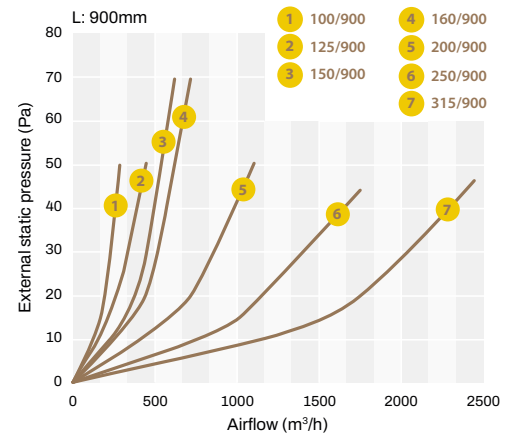

CODE	DESCRIPTION	Ø D [mm]	Ø D1 [mm]	L [mm]	L1 [mm]	WEIGHT [kg]	U.M.	Pieces per box
ACC400010	RIGID CIRCULAR SILENCER 100/900	124	225	900	50	4,1	PCS	1
ACC400011	RIGID CIRCULAR SILENCER 125/900	149	250	900	50	4,2	PCS	1
ACC400012	RIGID CIRCULAR SILENCER 150/900	159	260	900	50	4,6	PCS	1
ACC400013	RIGID CIRCULAR SILENCER 160/900	199	300	900	50	5,3	PCS	1
ACC400014	RIGID CIRCULAR SILENCER 200/900	249	359	900	50	6,2	PCS	1
ACC400015	RIGID CIRCULAR SILENCER 250/900	314	415	900	50	7,1	PCS	1
ACC400016	RIGID CIRCULAR SILENCER 315/900	314	415	900	50	7,1	PCS	1

UK SIMPLE FLOW VENTILATION BOX FOR MVHR SYSTEM

TECHNICAL SPECIFICATIONS

- Ideal for residential and commercial ventilation (public premises, bars, offices, etc.)
- For vertical and horizontal installation, wall / ceiling and floor
- Quiet and compact

FR BOÎTE DE VENTILATION À ÉCOULEMENT SIMPLE POUR SYSTÈME VMC

CARACTÉRISTIQUES TECHNIQUES

- Idéal pour la ventilation résidentielle et commerciale (locaux publics, bars, bureaux, etc.)
- Pour une installation verticale et horizontale, mur / plafond et sol
- Silencieux et compact

DE LÜFTERKASTEN EIN EINFACHFLUSS FÜR WRG-LÜFTUNG-ANLAGE

TECHNISCHE EIGENSCHAFTEN

- Ideal für Wohn- und Gewerbebelüftung (öffentliche Räumlichkeiten, Bürobars, etc.)
- Für die vertikale und horizontale Montage, an der Wand / Decke und Boden
- Leise und kompakt



Can also be used with the speed control (code 30360080)

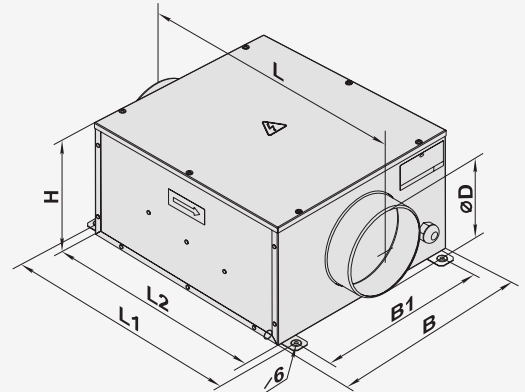

MOD.	DIMENSIONS [mm]							WEIGHT [kg]
	Ø D [mm]	B [mm]	B1 [mm]	H [mm]	L [mm]	L1 [mm]	L2 [mm]	
125	124	322	280	192	447	380	350	6,4
150	149	352	310	212	477	410	380	10,0
200	199	432	368	287	588	506	480	12,0
200 PLUS	199	432	368	287	588	506	480	12,5
250	249	432	368	287	588	506	480	12,5
315	314	502	438	397	588	506	480	12,5

TECHNICAL DATA						
MODEL	125	150	200	200 PLUS	250	315
POWER SUPPLY [V]	230					
FREQUENCY [HZ]	50					
POWER [W]	73	72	103	195	198	322
CURRENT [A]	0,32	0,32	0,45	0,85	0,87	1,40
AIR FLOW RATE [M³/H]	330	420	730	950	1300	2150
RPM	2590	2600	2550	2570	2420	2670
SOUND LEVEL 3 M [DB(A)]	35	36	38	41	41	43
MAX TEMPERATURE [°C]	-25 +55	-25 +55	-25 +55	-25 +55	-25 +55	-25 +55
PROTECTION RATING [IP]	IPX4					

CODE	DESCRIPTION	U.M.	 Pieces per box
30360010	SIMPLE-FLOW VENT CASING FOR MVHR SYSTEMS - MOD. 125	PCS	1
30360020	SIMPLE-FLOW VENT CASING FOR MVHR SYSTEMS - MOD. 150	PCS	1
30360030	SIMPLE-FLOW VENT CASING FOR MVHR SYSTEMS - MOD. 200	PCS	1
30360040	SIMPLE-FLOW VENT CASING FOR MVHR SYSTEMS - MOD. 200 PLUS	PCS	1
30360050	SIMPLE-FLOW VENT CASING FOR MVHR SYSTEMS - MOD. 250	PCS	1
30360060	SIMPLE-FLOW VENT CASING FOR MVHR SYSTEMS - MOD. 315	PCS	1

Datasheet



UK SPEED REGULATOR INCLUDING ASSEMBLY BOX FOR FAN BOXES

TECHNICAL SPECIFICATIONS

- Power supply 230 V
- Dimensions W 78 x H 63 x D 78 mm
- Maximum current: 1.8A
- Maximum operating temperature +40°C
- Plastic
- Protection rating IP 40
- Includes fastening box

FR RÉGULATEUR DE VITESSE COMPLET AVEC BOÎTIER DE MONTAGE POUR BOÎTIERS DE VENTILATEUR

CARACTÉRISTIQUES TECHNIQUES

- Alimentation 230 V
- Dimensions L 78 x H 63 x P 78 mm
- Courant maximal : 1,8 A
- Température maximale de fonctionnement +40°C
- Matériau plastique
- Degré de protection IP 40
- Livré avec boîte de fixation

DE DREHZAHLREGLER KOMPLETT MIT MONTAGEBOX FÜR LÜFTERBOXEN

TECHNISCHE EIGENSCHAFTEN

- Stromversorgung 230 V
- Abmessungen B 78 x H 63 x T 78 mm
- Max. Stromversorgung: 1,8 A
- Maximale Betriebstemperatur +40°C
- Kunststoff
- Schutzart IP 40
- Komplett mit Befestigungsgehäuse



CODE	DESCRIPTION	U.M.	Pieces per box
30360080	SPEED CONTROL FOR VENT CASINGS	PCS	1



UK INSULATED METAL SHEET FILTER HOLDER BOX

TECHNICAL SPECIFICATIONS

- Made of galvanized metal sheet
- External insulation in 3 mm thick polyethylene
- Equipped with 2 inlet / outlet collars
- Filter not included in price

FR BOÎTE PORTE FILTRE EN TÔLE ISOLÉE

CARACTÉRISTIQUES TECHNIQUES

- Fabriqué en tôle galvanisée
- Isolation externe en polyéthylène de 3 mm d'épaisseur
- Équipé de 2 colliers d'entrée / sortie
- Filtre non inclus dans le prix

DE FILTERKASTEN AUS ISOLIERTEM BLECH

TECHNISCHE EIGENSCHAFTEN

- Aus verzinktem Blech
- Außendämmung aus 3 mm starkem Polyethylen
- Mit 2 Schellen am Einlass / Auslass
- Filter nicht im Preis enthalten

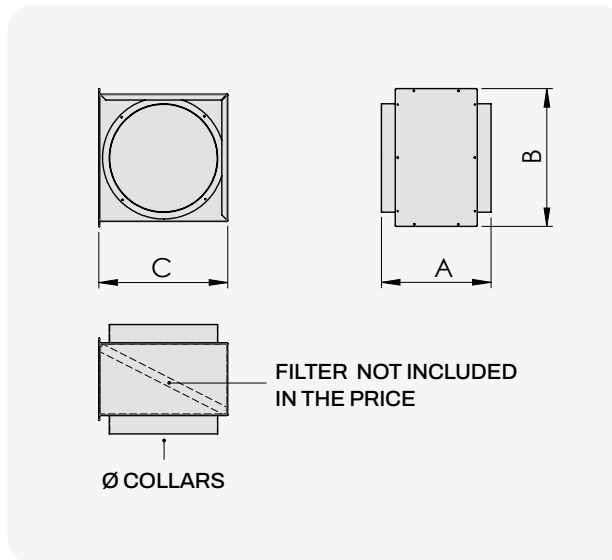

CODE	DESCRIPTION	A [mm]	B [mm]	C [MM]	INPUT Ø [mm]	OUTLET Ø [mm]	U.M.	Pieces per box
ACD600020	FILTER HOUSING IN INSULATED METAL SHEET, D. 150/200	397	270	246	150 / 200	150 / 200	PCS	1
ACD600021	FILTER HOUSING IN INSULATED METAL SHEET, D. 250	294	320	296	250	250	PCS	1
ACD600022	FILTER HOUSING IN INSULATED METAL SHEET, D. 300	294	420	396	300	300	PCS	1
ACD600023	FILTER HOUSING IN INSULATED METAL SHEET, Ø 350	294	370	346	350	350	PCS	1
ACD600024	FILTER HOUSING IN INSULATED METAL SHEET, D. 450	294	470	446	450	450	PCS	1

TOTAL AIR

 CO2 PROBE FOR HEAT RECOVERY UNIT

 SONDE CO₂ POUR RÉCUPÉRATEUR

 CO₂-SONDE FÜR RÜCKGEWINNER



CODE	DESCRIPTION	U.M.	 Pieces per box
ACD600027	CO2 A PROBE FOR "TOTAL AIR" HEAT RECOVERY UNIT	PCS	1
ACD600028	VOC SENSOR FOR HEAT RECOVERY UNITS "TOTAL AIR"	PCS	1

Probe for CO₂ Datasheet



Probe for VOC Datasheet



 220V SINGLE PHASE SPEED REGULATOR

The electronic speed regulator makes it possible to vary the air flow of the heat recovery element and of the barrier from 30% to 100% of its performance.

 RÉGULATEUR DE VITESSE MONOPHASÉ 220 V

Le régulateur de vitesse électronique permet de faire varier le débit d'air de l'unité de récupération de chaleur et de la barrière de 30% à 100% de ses performances.

 DREHZAHLREGLER 220V EINPHASIG

Mit dem elektronischen Drehzahlregler können Sie den Luftstrom der Wärmerückgewinnungseinheit und der Barriere von 30 % bis 100 % ihrer Leistung variieren.

CODE	DESCRIPTION	U.M.	 Pieces per box
12300100	SINGLE-PHASE 220V SPEED CONTROL MODEL 200-300-400-600	PCS	1
12300105	SINGLE-PHASE 220V SPEED CONTROL MODEL 800	PCS	1
12300110	SINGLE-PHASE 220V SPEED CONTROL MODEL 1000-1300	PCS	1
12300115	SINGLE-PHASE 220V SPEED CONTROL MODEL 1600-2100	PCS	1
12300120	SINGLE-PHASE 220V SPEED CONTROL MODEL 2500-3000	PCS	1

Datasheet



 PIPE IN EPS FOR MVHR Ø125 AND Ø160 L 1000 MM

TECHNICAL SPECIFICATIONS MODEL Ø125

- Grey colour EPS insulated pipe
- Wall thickness: 15.5mm
- Weight: 0,41 kg
- Dimensions: 156 x 156 x 1002 mm
- internal Ø: 125
- Temperature range -25 / +80 (C°)
- Maximum air flow: 275 m³/h
- Thermal resistance: 0.032 m²K/W

MODEL Ø160

- Grey colour EPS insulated pipe
- Wall thickness: 15.5mm
- Weight: 0,45 kg
- Dimensions: 191 x 191 x 1002 mm
- internal Ø: 160
- Temperature range -25 / +80 (C°)
- Maximum air flow: 425 m³/h
- Thermal resistance: 0.032 m²K/W

 TUBE EPS POUR VMC Ø125 ET Ø160 L.1000 MM

CARACTÉRISTIQUES TECHNIQUES MODEL Ø125

- Tube isolé EPS de couleur grise
- Épaisseur du mur : 15,5 mm
- Poids: 0,41 kg
- Dimensions: 156 x 156 x 1002 mm
- Ø intérieur: 125
- Plage de température -25 / +80 (C°)
- Débit d'air maximum : 275 m³/h
- Résistance thermique : 0,032 m²K/W

MODÈLE Ø160

- Tube isolé EPS de couleur grise
- Épaisseur du mur : 15,5 mm
- Poids: 0,45 kg
- Dimensions: 191 x 191 x 1002 mm
- Ø intérieur: 160
- Plage de température -25 / +80 (C°)
- Débit d'air maximum : 425 m³/h
- Résistance thermique : 0,032 m²K/W

 EPS-SCHLAUCH FÜR WRG-LÜFTUNG Ø125 UND Ø160 L.1000 MM

TECHNISCHE EIGENSCHAFTEN MODEL Ø125

- EPS-isoliertes Rohr in grauer Farbe
- Wandstärke: 15,5 mm
- Gewicht: 0,41 kg
- Abmessungen: 156 x 156 x 1002 mm
- Ø Innendurchmesser: 125
- Temperaturbereich: -25 / +80 (C°)
- Maximaler Luftdurchsatz: 275 m³/h
- Thermischer Widerstand: 0,032 m²K/W

MODEL Ø160

- EPS-isoliertes Rohr in grauer Farbe
- Wandstärke: 15,5 mm
- Gewicht: 0,45 kg
- Abmessungen: 191 x 191 x 1002 mm
- Ø Innendurchmesser: 160
- Temperaturbereich: -25 / +80 (C°)
- Maximaler Luftdurchsatz: 425 m³/h
- Thermischer Widerstand: 0,032 m²K/W

Datasheet



2 PCS/KIT

CODE	DESCRIPTION	U.M.	 Pieces per box
ACC600035	PIPE IN EPS FOR MVHR Ø 125 L.1000	PCS	1
ACC600036	PIPE IN EPS FOR MVHR Ø 160 L.1000	PCS	1

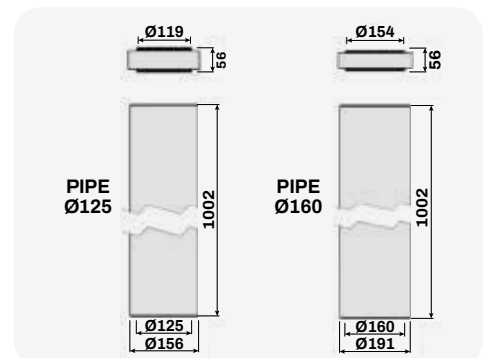

 90° ELBOW IN EPS FOR MVHR Ø125 / Ø160

 COURBE À 90° EN EPS POUR VMC Ø125 / Ø160

 90° WINKELSTÜCK AUS EPS FÜR WRG-LÜFTUNG Ø125 / Ø160

TECHNICAL SPECIFICATIONS
MODEL Ø125

- Grey colour EPS insulated elbow
- Wall thickness: 15.5mm
- Weight: 0,2 kg;
- Dimensions: 278 x 156 x 278 mm
- internal Ø: 125 mm
- Temperature range -25 / +80 (C°)
- Maximum air flow: 275 m³/h
- Thermal resistance: 0.032 m²K/W

MODEL Ø160

- Grey colour EPS insulated elbow
- Wall thickness: 15.5mm
- Weight: 0,24 kg
- Dimensions: 295 x 191 x 295 mm
- internal Ø: 160 mm
- Temperature range -25 / +80 (C°)
- Maximum air flow: 425 m³/h
- Thermal resistance: 0.032 m²K/W

CARACTÉRISTIQUES TECHNIQUES
MODEL Ø125

- Courbe isolée en EPS gris
- Épaisseur du mur : 15,5 mm
- Poids: 0,2 kg;
- Dimensions: 278 x 156 x 278 mm
- Ø intérieur: 125 mm
- Plage de température -25 / +80 (C°)
- Débit d'air maximum : 275 m³/h
- Résistance thermique : 0,032 m²K/W

MODEL Ø160

- Courbe isolée en EPS gris
- Épaisseur du mur : 15,5 mm
- Poids: 0,24 kg
- Dimensions: 295 x 191 x 295 mm
- Ø intérieur: 160 mm
- Plage de température -25 / +80 (C°)
- Débit d'air maximum : 425 m³/h
- Résistance thermique : 0,032 m²K/W

TECHNISCHE EIGENSCHAFTEN
MODELL Ø125

- EPS-isolierte Kurve in grauer Farbe
- Wandstärke: 15,5 mm
- Gewicht: 0,2 kg;
- Abmessungen: 278 x 156 x 278 mm
- Ø Innendurchmesser: 125 mm
- Temperaturbereich: -25 / +80 (C°)
- Maximaler Luftdurchsatz: 275 m³/h
- Thermischer Widerstand: 0,032 m²K/W

MODELL Ø160

- EPS-isolierte Kurve in grauer Farbe
- Wandstärke: 15,5 mm
- Gewicht: 0,24 kg
- Abmessungen: 295 x 191 x 295 mm
- Ø Innendurchmesser: 160 mm
- Temperaturbereich: -25 / +80 (C°)
- Maximaler Luftdurchsatz: 425 m³/h
- Thermischer Widerstand: 0,032 m²K/W

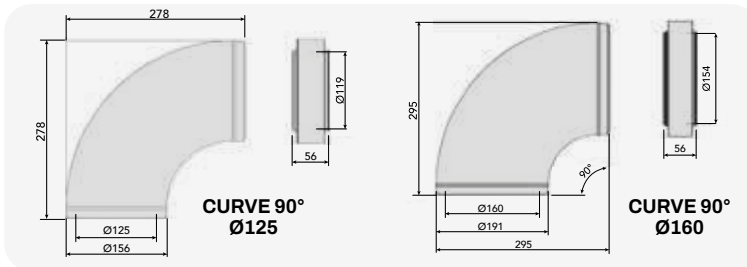

2 PCS/KIT

Datasheet



CODE	DESCRIPTION	U.M.	Pieces per box
ACC600037	90° ELBOW IN EPS FOR MVHR Ø 125mm	PCS	1
ACC600038	90° ELBOW IN EPS FOR MVHR Ø 160mm	PCS	1

 45° ELBOW IN EPS FOR MVHR Ø125 / Ø160

 COURBE À 45° EN EPS POUR VMC Ø125 / Ø160

 45° WINKELSTÜCK AUS EPS FÜR WRG-LÜFTUNG Ø125 / Ø160

TECHNICAL SPECIFICATIONS
MODEL Ø125

- Grey colour EPS insulated elbow
- Wall thickness: 15.5mm
- Weight: 0,15 kg
- Dimensions: 189 x 156 x 196 mm
- internal Ø: 125 mm
- Temperature range -25 / +80 (C°)
- Maximum air flow: 275 m³/h
- Thermal resistance: 0.032 m²K/W

MODEL Ø160

- Grey colour EPS insulated elbow
- Wall thickness: 15.5mm
- Weight: 0,18 kg
- Dimensions: 218 x 191 x 208 mm
- internal Ø: 160 mm
- Temperature range -25 / +80 (C°)
- Maximum air flow: 425 m³/h
- Thermal resistance: 0.032 m²K/W

CARACTÉRISTIQUES TECHNIQUES
MODEL Ø125

- Courbe isolée en EPS gris
- Épaisseur du mur : 15,5 mm
- Poids: 0,15 kg
- Dimensions: 189 x 156 x 196 mm
- Ø intérieur: 125 mm
- Plage de température -25 / +80 (C°)
- Débit d'air maximum : 275 m³/h
- Résistance thermique : 0,032 m²K/W

MODEL Ø160

- Courbe isolée en EPS gris
- Épaisseur du mur : 15,5 mm
- Poids: 0,18 kg
- Dimensions: 218 x 191 x 208 mm
- Ø intérieur: 160 mm
- Plage de température -25 / +80 (C°)
- Débit d'air maximum : 425 m³/h
- Résistance thermique : 0,032 m²K/W

TECHNISCHE EIGENSCHAFTEN
MODELL Ø125

- EPS-isolierte Kurve in grauer Farbe
- Wandstärke: 15,5 mm
- Gewicht: 0,15 kg
- Abmessungen: 189 x 156 x 196 mm
- Ø Innendurchmesser: 125 mm
- Temperaturbereich: -25 / +80 (C°)
- Maximaler Luftdurchsatz: 275 m³/h
- Thermischer Widerstand: 0,032 m²K/W

MODELL Ø160

- EPS-isolierte Kurve in grauer Farbe
- Wandstärke: 15,5 mm
- Gewicht: 0,18 kg
- Abmessungen: 218 x 191 x 208 mm
- Ø Innendurchmesser: 160 mm
- Temperaturbereich: -25 / +80 (C°)
- Maximaler Luftdurchsatz: 425 m³/h
- Thermischer Widerstand: 0,032 m²K/W

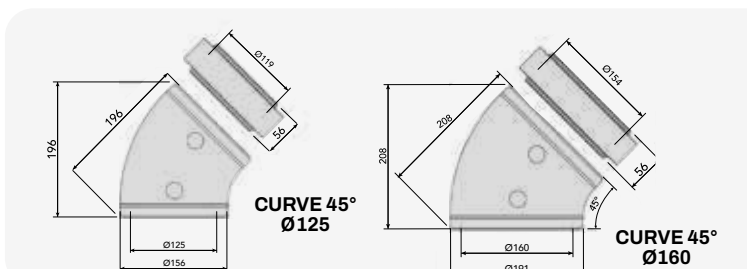

2 PCS/KIT

Datasheet



CODE	DESCRIPTION	U.M.	Pieces per box
ACC600039	45° ELBOW IN EPS FOR MVHR Ø 125mm	PCS	1
ACC600040	45° ELBOW IN EPS FOR MVHR Ø 160mm	PCS	1

 EPS COUPLING SLEEVE FOR MVHR
Ø125 / Ø160

 MANCHON DE RACCORDEMENT EPS
POUR VMC Ø125 / Ø160

 ANSCHLUSSMUFFE EPS FÜR WRG-
LÜFTUNG Ø125 / Ø160

TECHNICAL SPECIFICATIONS
MODEL Ø125

- Grey colour EPS sleeve
- internal Ø: 125 mm

MODEL Ø160

- Grey colour EPS sleeve
- internal Ø: 125 mm

CARACTÉRISTIQUES TECHNIQUES
MODEL Ø125

- Manchon EPS de couleur grise
- Ø intérieur: 125 mm

MODEL Ø160

- Manchon EPS de couleur grise
- Ø intérieur: 125 mm

TECHNISCHE EIGENSCHAFTEN
MODELL Ø125

- EPS-Hülle in grauer Farbe
- Ø Innendurchmesser: 125 mm

MODEL Ø160

- EPS-Hülle in grauer Farbe
- Ø Innendurchmesser: 125 mm

SLEEVE Ø125

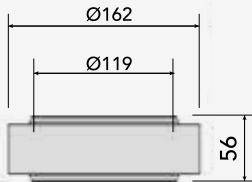

SLEEVE Ø160

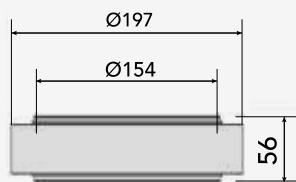

2 PCS/KIT

Datasheet



CODE	DESCRIPTION	U.M.	 Pieces per box
ACC600041	COUPLING SLEEVE IN EPS FOR MVHR Ø 125mm	PCS	1
ACC600042	COUPLING SLEEVE IN EPS FOR MVHR Ø 160mm	PCS	1

 ROUND FLEXIBLE HOSE AIR INLET
ANTI-STATIC, ANTIBACTERIAL WHITE
COLOUR

 TUYAU ROND ENTRÉE D'AIR
ANTISTATIQUE, ANTIBACTÉRIEN DE
COULEUR BLANCHE

 ANTISTATISCHER, ANTIBAKTERIELLER,
WEISSER, FLEXIBLER, RUNDER LUFTEIN-
LASSSCHLAUCH

TECHNICAL SPECIFICATIONS

- Double-walled hose, smooth interior with antistatic, antibacterial and antifungal additives
- Corrugated outer wall with extra protection against UV rays
- White with high protection against UV rays
- Resistance to compression greater than 500N, according to standards EN61386-1/2008 and EN61386-2-4/2010, with 5% internal diameter deformation
- Limitations of use: -20°C / +60°C
- Reaction to fire classification: Euroclass E (UNI EN13501)
- Minimum bending radius: four times the outer diameter

CARACTÉRISTIQUES TECHNIQUES

- Tube à double paroi, intérieur lisse réalisé avec des additifs anti-statiques, antibactériens et anti-fongiques
- Paroi extérieure ondulée construite avec une protection supplémentaire UV
- Couleur blanche à haute protection UV
- Résistance à l'écrasement supérieure à 500N selon les normes EN61386-1/2008 et EN61386-2-4/2010 avec une déformation de 5 % du diamètre interne
- Limites d'utilisation : -20°C / +60°C
- Classification et réaction au feu : Euroclasse E (UNI EN13501).
- Rayon de courbure minimal: quatre fois le diamètre extérieur

TECHNISCHE EIGENSCHAFTEN

- Doppelwandiges Rohr, innen glatt, konstruiert mit antistatischen, antibakteriellen und antimykotischen Zusätzen
- Gewellte Außenwand mit zusätzlichem UV-Schutz konstruiert
- Farbe Weiß mit hohem UV-Schutz
- Quetschfestigkeit größer als 500N nach EN61386-1/2008 und EN61386-2-4/2010 mit 5% Innendurchmesserverformung
- Einsatzgrenzen: -20°C / +60°C
- Klassifizierung und Brandverhalten: Euroklasse E (UNI EN13501)
- Min. Krümmungsradius: viermal der äußere Durchmesser

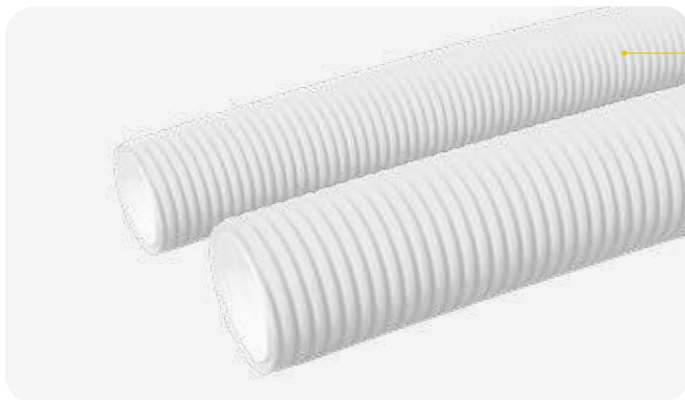

IDEAL FOR

- Intake systems
- Natural ventilation
- Mechanical ventilation heat recovery system (MVHR)
- Humidity control
- Heat exchange
- Air conditioning

Reaction to fire classification:
Euroclass E (UNI EN 13501)

CODE	DESCRIPTION	LENGTH [m]	INTERNAL Ø [mm]	EXTERNAL Ø [mm]	U.M.	 Pieces per box
ACC600021	ANTISTATIC, ANTIBACTERIAL, AIR INLET FLEXIBLE ROUND HOSE, D. 75 - WHITE	50	60	75	PCS	1
ACC600022	ANTISTATIC, ANTIBACTERIAL, AIR INLET FLEXIBLE ROUND HOSE, D. 92 - WHITE	50	73	92	PCS	1

Datasheet



EXPANDED POLYETHYLENE PIPE FOR ACOUSTIC INSULATION FOR Ø75 AND Ø92 PIPES

TECHNICAL SPECIFICATIONS

- Made of polyethylene
- Thickness 5 mm
- Maximum sound insulation result
- Extremely easy to install
- Pipe length 15 m
- Pre cuts about every 3 m

TUYAU EN POLYÉTHYLÈNE EXPANSÉ POUR ISOLATION ACOUSTIQUE POUR TUYAUTERIES Ø75 ET Ø92

CARACTÉRISTIQUES TECHNIQUES

- Fabriqué en polyéthylène
- Épaisseur 5 mm
- Résultat d'isolation acoustique maximal
- Extrêmement facile à installer
- Longueur du tuyau 15 m
- Pré coupes environ tous les 3 m

POLYETHYLENSCHAUMROHR ZUR SCHALLDÄMMUNG FÜR Ø75 UND Ø92 ROHRE

TECHNISCHE EIGENSCHAFTEN

- Aus Polyethylen
- Dicke 5 mm
- Maximales Ergebnis der Schalldämmung
- Extrem einfache Installation
- Rohrlänge 15 m
- Vorgeschnitten Ca. Jede 3m

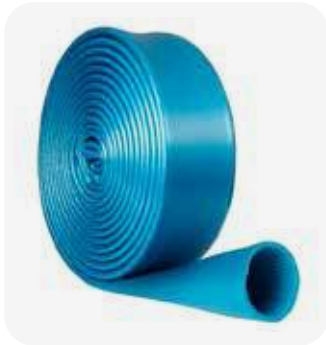

CODE	DESCRIPTION	U.M.	Pieces per box
ACC600033	EXPANDED POLYETHYLENE PIPE FOR ACOUSTIC INSULATION FOR PIPES Ø 75 MM	PCS	1
ACC600034	EXPANDED POLYETHYLENE PIPE FOR ACOUSTIC INSULATION FOR PIPES Ø 92 MM	PCS	1

Datasheet



HOSE CONNECTOR FOR CASSETTE AND PLENUM Ø75 MM AND Ø92 MM

CONNECTEUR DE TUYAU POUR CAISSON ET PLENUM Ø75 MM ET Ø92 MM

SCHLAUCHANSCHLUSS FÜR KASTEN UND ANSCHLUSSKASTEN Ø75 MM UND Ø92 MM



Possibility of installation on customized plenum in PAL

CODE	DESCRIPTION	U.M.	Pieces per box
30100120	COMPLETE CONNECTOR D.75 MM	PCS	1
30100200	COMPLETE CONNECTOR D.92 MM	PCS	1

Datasheet



DIAPHRAGM FOR DISTRIBUTION BOX

MEMBRANE POUR BOÎTE DE DISTRIBUTION

MEMBRAN FÜR VERTEILERKASTEN



CODE	DESCRIPTION	U.M.	Pieces per box
30100090	BAFFLE FOR MANIFOLD BOX	PCS	1

Datasheet



 AIR INLET FLEXIBLE HOSE SLEEVE

 MANCHON POUR TUYAU FLEXIBLE ENTRÉE AIR

 MUFFE FÜR LUFTEIN- LASSSCHLAUCH



CODE	DESCRIPTION	U.M.	 Pieces per box
30100130	SLEEVE Ø 75 FOR FLEXIBLE HOSE	PCS	1
30100210	SLEEVE Ø 92 FOR FLEXIBLE HOSE	PCS	1

Datasheet



 DUST CAP

 BOUCHON ANTI-POUSSIÈRE

 STAUBSCHUTZKAPPE



CODE	DESCRIPTION	U.M.	 Pieces per box
30100160	DUST-COVER D.75	PCS	1
30100170	DUST-COVER FOR CONNECTOR D.75	PCS	1
30100250	DUST CAP Ø 92 FOR FLEXIBLE PIPE	PCS	1

Datasheet



 90° ELBOW CURVE

 COURBE À COUDE À 90°

 90°-KURVE



90° Curve with connection for corrugated pipes, with sealing hooks and o-ring seals.

CODE	DESCRIPTION	U.M.	 Pieces per box
30100180	BEND 90° D.75	PCS	1
30100260	BEND 90° D.92	PCS	1

Datasheet



 90° ELBOW CURVE FOR FLOOR FOR FLOOR

 COURBE À COUDE À 90° POUR SOL

 90°KURVE FÜR BODEN



90° Curve with connection for corrugated pipes, to be positioned on the floor, with sealing hooks and o-ring seals.

CODE	DESCRIPTION	U.M.	 Pieces per box
30100190	90° BEND FOR FLOOR D.75	PCS	1
30100270	90° BEND FOR FLOOR D.92	PCS	1

Datasheet



 90° FITTING FOR FLEXIBLE HOSE Ø 75 AND GRID

 RACCORD 90° POUR TUYAN FLEXIBLE Ø 75 ET GRILLE

 90°-VERSCHRAUBUNG FÜR Ø 75 MM SCHLAUCH UND GITTER



90° connection for distribution terminal including connection plate, sealing hooks and dust plugs.

CODE	DESCRIPTION	U.M.	 Pieces per box
30100140	FITTING 90° D.75 MM	PCS	1

[Datasheet](#)



 STRAIGHT FITTING FOR FLEXIBLE HOSE Ø 75 AND GRID

 RACCORD DROIT POUR TUYAN FLEXIBLE Ø 75 ET GRILLE

 GERADE VERSCHRAUBUNG FÜR SCHLAUCH Ø 75 MM UND GITTER



Straight fitting for grid connection, including plugs, sealing hooks and connecting plate.

CODE	DESCRIPTION	U.M.	 Pieces per box
30100150	STRAIGHT FITTING 90° D. 75 MM	PCS	1

[Datasheet](#)



 90° FITTING FOR FLEXIBLE HOSE Ø 92 AND GRID

 RACCORD 90° POUR TUYAN FLEXIBLE Ø 92 ET GRILLE

 90°-VERSCHRAUBUNG FÜR Ø 92 MM SCHLAUCH UND GITTER



90° connection for flexible corrugated pipes for connection to the grid. Complete with sealing hooks and connection plate.

CODE	DESCRIPTION	U.M.	 Pieces per box
30100220	FITTING 90° D.92 MM	PCS	1

[Datasheet](#)



 STRAIGHT FITTING FOR FLEXIBLE HOSE Ø 92 AND GRID

 RACCORD DROIT POUR TUYAN FLEXIBLE Ø 92 ET GRILLE

 GERADE VERSCHRAUBUNG FÜR SCHLAUCH Ø 92 MM UND GITTER

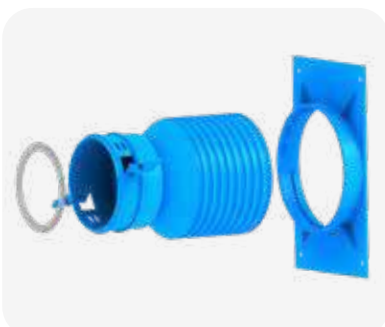

Straight fitting for flexible corrugated pipes for connection to the grid. Complete with sealing hooks and connection plate.

CODE	DESCRIPTION	U.M.	 Pieces per box
30100240	STRAIGHT FITTING FOR HOSE D. 92 MM AND GRILLE	PCS	1

[Datasheet](#)



 **OVAL AIR INLET FLEXIBLE HOSE**

TECHNICAL SPECIFICATIONS

- Double-walled HDPE corrugated hose
- Self-extinguishing treatment
- Anti-UV
- Antistatic
- Sub-track installation

 **TUYAN FLEXIBLE OVALE ENTRÉE D'AIR**

CARACTÉRISTIQUES TECHNIQUES

- Tuyau ondulé en PEHD à double paroi
- Traitement auto-extinguible
- Anti-UV
- Antistatique
- Installation sous gaine

 **FLEXIBLER OVALE LUFTEINLASSSCHLAUCH**

TECHNISCHE EIGENSCHAFTEN

- Doppelwandiger HDPE-Wellschlauch
- Selbstlöschende Behandlung
- UV-Schutz
- Antistatisch
- Montage unter Putz



NOTE: The transport costs are totally charged to the customer

CODE	DESCRIPTION	U.M.	 Pieces per box
30101010	OVAL FLEXIBLE HOSE FOR AIR INLET 120X44	PCS	1

Datasheet



 **OVAL FLEXIBLE HOSE CONNECTOR FOR AIR INLET**

 **CONNECTEUR POUR TUYAU OVALE FLEXIBLE D'ENTRÉE D'AIR**

 **ANSCHLUSS FÜR OVALEN LUFTEINLASS-SCHLAUCH**



CODE	DESCRIPTION	U.M.	 Pieces per box
30101030	SLEEVE FOR FLEXIBLE OVAL HOSE AT AIR INLET	PCS	1

Datasheet



 **COUPLING SLEEVE FOR OVAL FLEXIBLE HOSE**

 **MANCHON DE RACCORDEMENT POUR TUYAN FLEXIBLE OVALE**

 **ANSCHLUSSMUFFE FÜR OVALEN UND FLEXIBLEN SCHLAUCH**

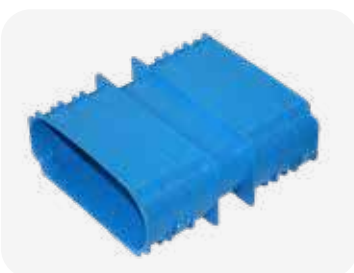

CODE	DESCRIPTION	U.M.	 Pieces per box
30101040	SLEEVE FOR FLEXIBLE OVAL HOSE AT AIR INLET	PCS	1

Datasheet



 **HORIZONTAL OVAL ELBOW CURVE**

 **COURBE À COUDE OVALE HORIZONTALE**

 **HORIZONTALE OVALE ELLENBOGEN KURVE**



90° Curve with connection for corrugated pipes, with sealing hooks and o-ring seals.

CODE	DESCRIPTION	U.M.	 Pieces per box
30101050	HORIZONTAL OVAL ELBOW CURVE	PCS	1

Datasheet



 VERTICAL OVAL ELBOW CURVE

 COURBE À COUDE OVALE VERTICALE

 VERTIKALE OVALE OVALE ELLENBOGEN KURVE



90° Curve with connection for corrugated pipes, with sealing hooks and o-ring seals.

CODE	DESCRIPTION	U.M.	 Pieces per box
30101060	VERTICAL OVAL ELBOW CURVE	PCS	1

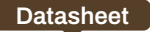
 Datashield



 90° CONNECTION FOR OVAL FLEXIBLE HOSE AND GRID

 RACCORD À 90° POUR TUYAN FLEXIBLE OVALE ET GRILLE

 90°-VERSCHRAUBUNG FÜR OVALEN UND FLEXIBLEN SCHLAUCH UND GITTER



90° curve for oval flexible hose. Complete with sealing hooks and o-rings.

CODE	DESCRIPTION	U.M.	 Pieces per box
30101070	90° ELBOW FITTING FOR OVAL HOSEING AND GRILLE	PCS	1

 Datashield



 ROUND/OVAL FITTING FOR AIR INLET FLEXIBLE HOSE

 RACCORD ROND/OVALE POUR TUYAN FLEXIBLE ENTRÉE AIR

 RUNDE/OVALE VERSCHRAUBUNG FÜR LUFTEIN-LASSSCHLAUCH



Adapter for connection of oval flexible hose and round flexible hose (Ø92/75). Complete with sealing hooks.

CODE	DESCRIPTION	U.M.	 Pieces per box
30101080	ROUND-OVAL ADAPTOR FOR FLEXIBLE AIR-INLET HOSE	PCS	1
ACC600043	ROUND-OVAL FITTING FOR AIR INLET FLEXIBLE HOSE Ø75 MM	PCS	1

 Datashield



 OVAL GASKET IN EPDM

 JOINT OVALE EN EPDM

 OVALE DICHTUNG AUS EPDM



Oval hose seal gasket for flexible tubes made of EPDM.

CODE	DESCRIPTION	U.M.	 Pieces per box
30101100	OVAL GASKET IN EPDM	PCS	1

 Datashield



 DELIVERY/INTAKE PLENUM IN PAL FOR CUSTOM MVHR

 BOÎTE DE DISTRIBUTION / RÉCUPÉRATION EN PAL POUR VMC SUR MESURE

 VERTEILER-/RÜCKFÜHRKASTEN AUS PAL FÜR CMB AUF MASS



The plenum can be equipped with collars. The costs of the collars is to charge extra. When placing the order, please indicate clearly you need the collars providing the quantity and where to install them.

Confirm the external dimensions of the plenum (A x B x C). Please consider always the 20 mm thickness of the PAL panel.





Datasheet

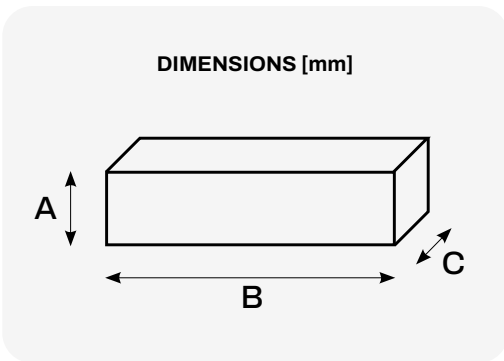

Insulation 20 mm

Custom made



CODE	DESCRIPTION	INTERNAL HEIGHT A [mm]	INTERNAL WIDTH B [mm]	DEPTH C [mm]	NO.OF OUTPUTS	U.M.	 Pieces per box
30100042	"MOD 1" - SUPPLY/RETURN PLENUM IN PAL - 300X1000X280	Up to 300	Up to 1000	260 fixed	Up to 6 outputs*	PCS	1
30100044	"MOD 2" - SUPPLY / RETURN PLENUM IN PAL - 400X1200X280	Up to 400	Up to 1200	260 fixed	Up to 12 outputs*	PCS	1
30100046	"MOD 3" - SUPPLY / RETURN PLENUM IN PAL 1300X1500X280	Up to 400	Up to 1500	260 fixed	Up to 18 outputs*	PCS	1

* The quantity of collars varies according to the dimensions of the plenum itself and to the kind of collar you choose.

 **GALVANISED METAL SHEET SOUNDPROOFED PLENUM 4-6-8-10-12 OUTPUTS Ø 75 WITH CONNECTORS COMPLETE WITH CALIBRATION DAMPER WITH ADJUSTMENT**

 **PLENUM INSONORISEN EN TÔLE ZINGUÉE 4-6-8-10-12 SORTIES Ø 75 AVEC CONNECTEURS DOTÉS DE REGISTRE D'ÉTALLONAGE AVEC RÉGLAGE**

 **SCHALLGEDÄMMTES PLENUM AUS VERZINKTEM BLECH 4-6-8-10-12 AUSGÄNGE Ø 75 MIT STECKVERBINDERN, KOMPLETT MIT KALIBRIERKLAPPE UND REGULIERUNG**

TECHNICAL SPECIFICATIONS

- Made of galvanized metal sheet
- High noise insulation
- Internal noise absorber thickness 20mm
- Removable soundproofing septa
- Complete with brackets for ceiling mounting
- Output/input collars as per table
- Sleeves complete with calibration damper with graduated adjustment by screwdriver

CARACTÉRISTIQUES TECHNIQUES

- Fabriqué en tôle galvanisée
- Isolation acoustique élevée
- Insonorisant intérieur épaisseur 20mm
- Septums insonorisants amovibles
- Complet avec supports de montage au plafond
- Colliers de sortie/entrée selon tableau
- Manchons de serrage d'étalonnage avec réglage gradué par tournevis

TECHNISCHE EIGENSCHAFTEN

- Aus verzinktem Blech
- Hohe Schalldämmung
- Schalldämpfende Innenwandstärke 20mm
- Abnehmbare schallabsorbierende wände
- Komplett mit Halterungen für Deckenmontage
- Halsbänder Ausgang/Eingang gemäss Tabelle
- Komplett mit Justierklappe mit Schraubendreherregulierung

 **MADE IN ITALY**



Removable soundproofing septa

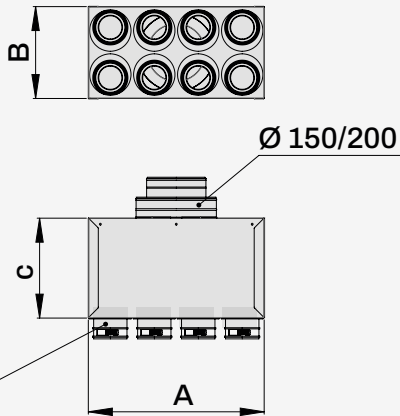



CODE	A	B	C
	[mm]	[mm]	[mm]
ACD600121	360	240	500
ACD600122	360	240	500
ACD600123	660	240	500
ACD600124	660	240	500
ACD600125	660	240	500
ACD600126	360	240	500
ACD600127	360	240	500

Datasheet



CODE	DESCRIPTION	INPUT Ø [mm]	U.M.	 Pieces per box
ACD600121	SOUNDPROOF PLENUM MADE OF GALVANIZED METAL SHEET Ø 75 - 4 OUTLETS 150/200	150 / 200	PCS	1
ACD600122	SOUNDPROOF PLENUM MADE OF GALVANIZED METAL SHEET Ø 75 - 6 OUTLETS 150/200	150 / 200	PCS	1
ACD600123	SOUNDPROOF PLENUM MADE OF GALVANIZED METAL SHEET Ø 75 - 8 OUTLETS 150/200	150 / 200	PCS	1
ACD600124	SOUNDPROOF PLENUM MADE OF GALVANIZED METAL SHEET Ø 75 - 10 OUTLETS 150/200	150 / 200	PCS	1
ACD600125	SOUNDPROOF PLENUM MADE OF GALVANIZED METAL SHEET Ø 75 - 12 OUTLETS 150/200	150 / 200	PCS	1
ACD600126	SOUNDPROOF PLENUM MADE OF GALVANIZED METAL SHEET Ø 75 - 4 OUTLETS 100 / 125 / 150	100 / 125 / 150	PCS	1
ACD600127	SOUNDPROOF PLENUM MADE OF GALVANIZED METAL SHEET Ø 75 - 6 OUTLETS 100 / 125 / 150	100 / 125 / 150	PCS	1

 **GALVANISED METAL SHEET SOUNDPROOFED PLENUM 4-6-8-10-12 OUTPUTS Ø 90 WITH CONNECTORS COMPLETE WITH CALIBRATION DAMPER WITH ADJUSTMENT**

 **PLENUM INSONORISEN EN TÔLE ZINGUÉE 4-6-8-10-12 SORTIES Ø 90 AVEC CONNECTEURS DOTÉS DE REGISTRE D'ÉTALLONAGE AVEC RÉGLAGE**

 **SCHALLGEDÄMMTES PLENUM AUS VERZINKTEM BLECH 4-6-8-10-12 AUSGÄNGE Ø 90 MIT STECKVERBINDERN, KOMPLETT MIT KALIBRIERKLAPPE UND REGULIERUNG**

TECHNICAL SPECIFICATIONS

- Made of galvanized metal sheet
- High noise insulation
- Internal noise absorber thickness 20mm
- Removable soundproofing septa
- Complete with brackets for ceiling mounting
- Output/input collars as per table
- Sleeves complete with calibration damper with graduated adjustment by screwdriver

CARACTÉRISTIQUES TECHNIQUES

- Fabriqué en tôle galvanisée
- Isolation acoustique élevée
- Insonorisant intérieur épaisseur 20mm
- Septums insonorisants amovibles
- Complet avec supports de montage au plafond
- Colliers de sortie/entrée selon tableau
- Manchons de serrage d'étalonnage avec réglage gradué par tournevis

TECHNISCHE EIGENSCHAFTEN

- Aus verzinktem Blech
- Hohe Schalldämmung
- Schalldämpfende Innenwandstärke 20mm
- Abnehmbare schallabsorbierende Wände
- Komplett mit Halterungen für Deckenmontage
- Ausgang/Eingang mufte gemäss Tabelle
- Komplett mit Justierklappe mit Schraubendreherregulierung

 **MADE IN ITALY**



Removable soundproofing septa

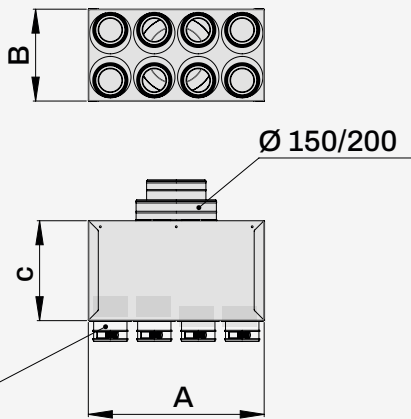

CODE	A	B	C
	[mm]	[mm]	[mm]
ACD600128	360	240	500
ACD600129	360	240	500
ACD600130	660	240	500
ACD600131	660	240	500
ACD600132	660	240	500
ACD600133	360	240	500
ACD600134	360	240	500

Datasheet



CODE	DESCRIPTION	INPUT Ø [mm]	U.M.	 Pieces per box
ACD600128	SOUNDPROOF PLENUM MADE OF GALVANIZED METAL SHEET Ø 90 - 4 OUTLETS 150/200	150 / 200	PCS	1
ACD600129	SOUNDPROOF PLENUM MADE OF GALVANIZED METAL SHEET Ø 90 - 6 OUTLETS 150/200	150 / 200	PCS	1
ACD600130	SOUNDPROOF PLENUM MADE OF GALVANIZED METAL SHEET Ø 90 - 8 OUTLETS 150/200	150 / 200	PCS	1
ACD600131	SOUNDPROOF PLENUM MADE OF GALVANIZED METAL SHEET Ø 90 - 10 OUTLETS 150/200	150 / 200	PCS	1
ACD600132	SOUNDPROOF PLENUM MADE OF GALVANIZED METAL SHEET Ø 90 - 12 OUTLETS 150/200	150 / 200	PCS	1
ACD600133	SOUNDPROOF PLENUM MADE OF GALVANIZED METAL SHEET Ø 90 - 4 OUTLETS 100 / 125 / 150	100 / 125 / 150	PCS	1
ACD600134	SOUNDPROOF PLENUM MADE OF GALVANIZED METAL SHEET Ø 90 - 6 OUTLETS 100 / 125 / 150	100 / 125 / 150	PCS	1

INSULATED PLENUM IN METAL SHEET FOR FLEXIBLE DUCTED PIPE 2 - 3 - 4 - 5 OUTPUTS Ø 150

TECHNICAL SPECIFICATIONS

- Made of galvanized metal sheet
- External insulation in 3 mm thick polyethylene
- Air inlet collar with double diameter with hose connection Ø 150 - 200
- Outgoing collars as shown in the table
- Complete with brackets for ceiling mounting

BOÎTE EN TÔLE ISOLÉE POUR TUYAU CANALISÉ FLEXIBLE 2 - 3 - 4 - 5 SORTIES Ø 150

CARACTÉRISTIQUES TECHNIQUES

- Fabriqué en tôle galvanisée
- Isolation externe en polyéthylène de 3 mm d'épaisseur
- Collier d'entrée d'air à double diamètre avec raccord pour tuyaux Ø 150 - 200
- Colliers sortants comme indiqué dans le tableau
- Dotés de supports pour montage au plafond

ISOLIERTER BLECHKASTEN FÜR KANALISIERTEN SCHLAUCH 2 - 3 - 4 - 5 AUSGÄNGE Ø 150

TECHNISCHE EIGENSCHAFTEN

- Aus verzinktem Blech
- Außendämmung aus 3 mm starkem Polyethylen
- Lufteinlassschelle mit doppeltem Durchmesser mit Rohranschluss Ø 150 - 200
- Schellen am Ausgang laut Tabelle
- Komplett mit Halterungen für Deckenmontage

MADE IN ITALY

EXAMPLE PLENUM 8 OUTPUTS



* Lateral or upper inlet on request

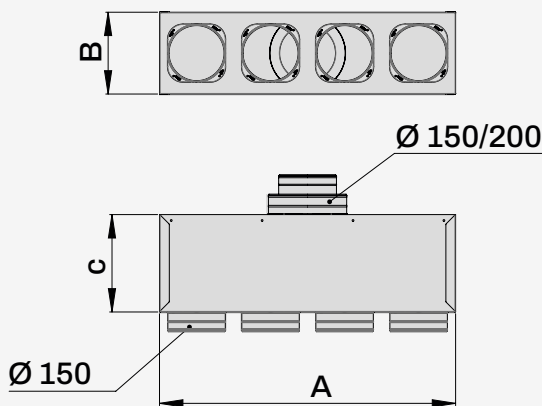

CODE	A	B	C
	[mm]	[mm]	[mm]
ACD600001	380	210	250
ACD600002	570	210	250
ACD600003	760	210	250
ACD600004	950	210	250

Datasheet



CODE	DESCRIPTION	INPUT Ø [mm]	OUTPUT N° - [mm]	U.M.	Pieces per box
ACD600001	INSULATED METAL SHEET PLENUM FOR FLEXIBLE HOSE WITH 2 OUTLETS, Ø150	150 / 200	2 - 150	PCS	1
ACD600002	INSULATED METAL SHEET PLENUM FOR FLEXIBLE HOSE WITH 3 OUTLETS, Ø150	150 / 200	3 - 150	PCS	1
ACD600003	INSULATED METAL SHEET PLENUM FOR FLEXIBLE HOSE WITH 4 OUTLETS, Ø150	150 / 200	4 - 150	PCS	1
ACD600004	INSULATED METAL SHEET PLENUM FOR FLEXIBLE HOSE WITH 5 OUTLETS, Ø150	150 / 200	5 - 150	PCS	1

 **INSULATED PLENUM IN METAL SHEET FOR FLEXIBLE DUCTED PIPE 4 - 6 - 8 - 10 - 12 OVAL OUTPUTS 120 X 35**

TECHNICAL SPECIFICATIONS

- Made of galvanized metal sheet
- External insulation in 3 mm thick polyethylene
- Air inlet collar with double diameter with hose connection Ø 150 - 200
- Outgoing collars as shown in the table
- Complete with brackets for ceiling mounting

 **BOÎTE EN TÔLE ISOLÉE POUR TUYAU CANALISÉ FLEXIBLE 4 - 6 - 8 - 10 - 12 SORTIES OVALES 120 X 35**

CARACTÉRISTIQUES TECHNIQUES

- Fabriqué en tôle galvanisée
- Isolation externe en polyéthylène de 3 mm d'épaisseur
- Collier d'entrée d'air à double diamètre avec raccord pour tuyaux Ø 150 - 200
- Colliers sortants comme indiqué dans le tableau
- Dotés de supports pour montage au plafond

 **ISOLIERTER BLECHKASTEN FÜR KANALISIERTEN SCHLAUCH 4 - 6 - 8 - 10 - 12 OVALE AUSGÄNGE 120 X 35**

TECHNISCHE EIGENSCHAFTEN

- Aus verzinktem Blech
- Außendämmung aus 3 mm starkem Polyethylen
- Lufteinlassschelle mit doppeltem Durchmesser mit Rohrschluss Ø 150 - 200
- Schellen am Ausgang laut Tabelle
- Komplett mit Halterungen für Deckenmontage

 **MADE IN ITALY**

EXAMPLE PLENUM 8 OUTPUTS

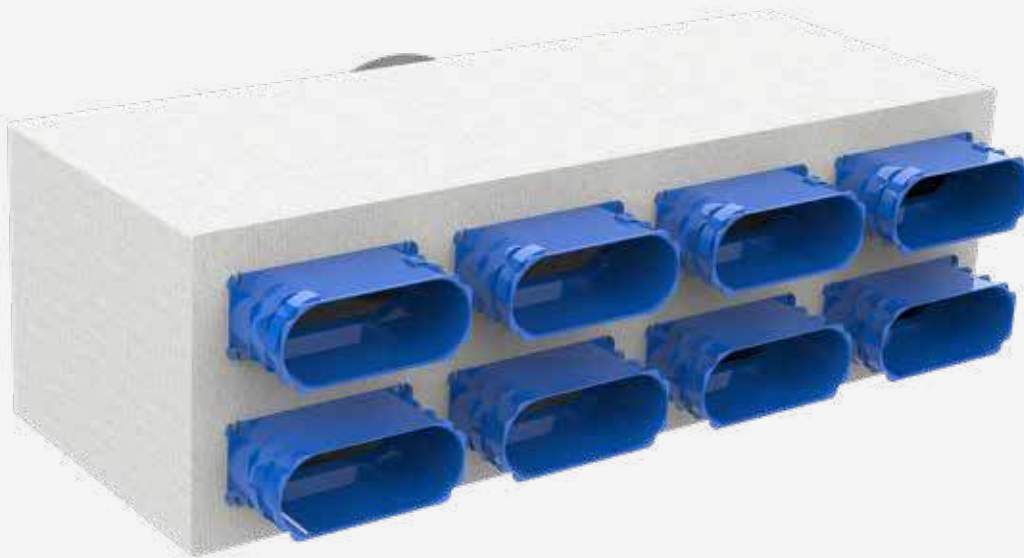

* Lateral or upper inlet on request

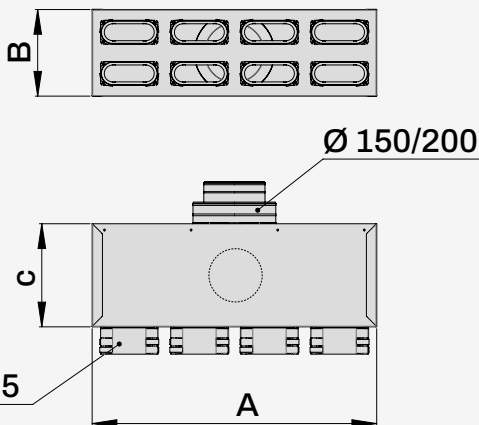

CODE	A	B	C
	[mm]	[mm]	[mm]
ACD600007	350	210	250
ACD600010	520	210	250
ACD600013	690	210	250
ACD600016	860	210	250
ACD600019	1030	210	250

Datasheet



CODE	DESCRIPTION	INPUT Ø [mm]	U.M.	 Pieces per box
ACD600007	INSULATED METAL SHEET PLENUM FOR FLEXIBLE HOSE WITH 4 OVAL OUTLETS 120X35	150 / 200	PCS	1
ACD600010	INSULATED METAL SHEET PLENUM FOR FLEXIBLE HOSE WITH 6 OVAL OUTLETS 120X35	150 / 200	PCS	1
ACD600013	INSULATED METAL SHEET PLENUM FOR FLEXIBLE HOSE WITH 8 OVAL OUTLETS 120X35	150 / 200	PCS	1
ACD600016	INSULATED METAL SHEET PLENUM FOR FLEXIBLE HOSE WITH 10 OVAL OUTLETS 120X35	150 / 200	PCS	1
ACD600019	INSULATED SHEET METAL PLENUM FOR FLEXIBLE HOSE WITH 12 OVAL OUTLETS 120X35	150 / 200	PCS	1

 **INSULATED DISTRIBUTION PLENUM FOR MVHR FOR FLEXIBLE DUCTED HOSE 4-6-8-10-12 OUTPUTS Ø 75 WITH SLEEVES COMPLETE WITH CALIBRATION DAMPER WITH ADJUSTMENT**

TECHNICAL SPECIFICATIONS

- Made of galvanized metal sheet
- 3 mm thick polyethylene external insulation
- Available with double collar Ø150 - Ø200 or triple by Ø100 - Ø125 - Ø150
- Outgoing collars as shown in the table
- Complete with brackets for ceiling mounting
- Holes provided for the entry of the upper and rear collar
- Sleeves complete with calibration damper with graduated adjustment by screwdriver
- Plenum supplied pre-assembled

 **PLENUM ISOLÉ DE DISTRIBUTION POUR VMC POUR TUBE FLEXIBLE 4-6-8-10-12 SORTIES Ø 75 AVEC MANCHONS DOTÉS DE REGISTRE D'ÉTALONNAGE AVEC RÉGLAGE**

CARACTÉRISTIQUES TECHNIQUES

- Fabriqué en tôle galvanisée
- Isolation extérieure en polyéthylène de 3 mm d'épaisseur
- Disponible avec un col double Ø150 - Ø200 ou triple Ø100 - Ø125 - Ø150
- Colliers sortants comme indiqué dans le tableau
- Dotés de supports pour montage au plafond
- Trous prévus pour l'entrée du collier supérieur et arrière
- Manchons de serrage d'étalonnage avec réglage gradué par tournevis
- Plenum fourni prémonté

 **ISOLIERTES VERTEILER- PLENUM FÜR KWL FÜR KANALISIERTEN SCHLAUCH 4-6-8-10-12 AUSGÄNGE Ø 75 MIT MUFFEN, KOMPLETT MIT KALIBRIERKLAPPE MIT REGULIERUNG**

TECHNISCHE EIGENSCHAFTEN

- Aus verzinktem Blech
- Externe Polyethylen-Dämmung st. 3mm
- Erhältlich mit Doppelkragen Ø150 - Ø200 oder Dreifach aus Ø100 - Ø125 - Ø150
- Schellen am Ausgang laut Tabelle
- Komplett mit Halterungen für Deckenmontage
- Einschubbohrungen für Ober- und Rückseite
- Komplett mit Justierklappe mit Schraubendreherregulierung
- vormontierte gelieferte Plenum

 **MADE IN ITALY**

EXAMPLE PLENUM 8 OUTPUTS

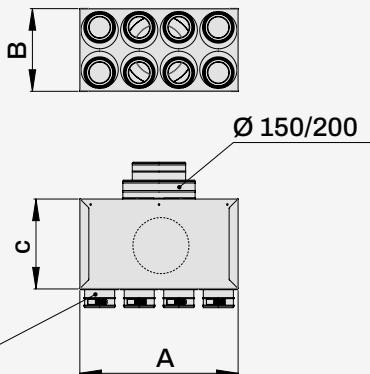

CODE	A	B	C
	[mm]	[mm]	[mm]
ACD600107	230	240	250
ACD600108	350	240	250
ACD600109	465	240	250
ACD600110	580	240	250
ACD600111	700	240	250
ACD600112	230	240	250
ACD600113	350	240	250

Datasheet



CODE	DESCRIPTION	INPUT Ø [mm]	U.M.	 Pieces per box
ACD600107	MVHR INSULATED METAL SHEET PLENUM FOR FLEXIBLE CORRUGATED PIPE Ø75 4 OUTLETS Ø150/200	150 / 200	PCS	1
ACD600108	MVHR INSULATED METAL SHEET PLENUM FOR FLEXIBLE CORRUGATED PIPE Ø75 6 OUTLETS Ø150/200	150 / 200	PCS	1
ACD600109	MVHR INSULATED METAL SHEET PLENUM FOR FLEXIBLE CORRUGATED PIPE Ø75 8 OUTLETS Ø150/200	150 / 200	PCS	1
ACD600110	MVHR INSULATED METAL SHEET PLENUM FOR FLEXIBLE CORRUGATED PIPE Ø75 10 OUTLETS Ø150/200	150 / 200	PCS	1
ACD600111	MVHR INSULATED METAL SHEET PLENUM FOR FLEXIBLE CORRUGATED PIPE Ø75 12 OUTLETS Ø150/200	150 / 200	PCS	1
ACD600112	MVHR INSULATED METAL SHEET PLENUM FOR FLEXIBLE CORRUGATED PIPE Ø75 4 OUTLETS Ø100/125/150	100 / 125 / 150	PCS	1
ACD600113	MVHR INSULATED METAL SHEET PLENUM FOR FLEXIBLE CORRUGATED PIPE Ø75 6 OUTLETS Ø100/125/150	100 / 125 / 150	PCS	1

 **INSULATED DISTRIBUTION PLENUM FOR MVHR FOR FLEXIBLE DUCTED HOSE 4-6-8-10-12 OUTPUTS Ø 90 WITH SLEEVES COMPLETE WITH CALIBRATION DAMPER WITH ADJUSTMENT**

TECHNICAL SPECIFICATIONS

- Made of galvanized metal sheet
- 3 mm thick polyethylene external insulation
- Available with inlet collar Ø150
- Outgoing collars as shown in the table
- Complete with brackets for ceiling mounting
- Sleeves complete with calibration damper with graduated adjustment by screwdriver
- Plenum supplied pre-assembled

 **PLENUM ISOLÉ DE DISTRIBUTION POUR VMC POUR TUBE FLEXIBLE 4-6-8-10-12 SORTIES Ø 90 AVEC MANCHONS DOTÉS DE REGISTRE D'ÉTALONNAGE AVEC RÉGLAGE**

CARACTÉRISTIQUES TECHNIQUES

- Fabriqué en tôle galvanisée
- Isolation extérieure en polyéthylène de 3 mm d'épaisseur
- Disponible avec collier d'entrée Ø150
- Colliers sortants comme indiqué dans le tableau
- Complet avec supports de montage au plafond
- Manchons de serrage d'étalonnage avec réglage gradué par tournevis
- Plenum fourni prémonté

 **ISOLIERTES VERTEILER-PLENUM FÜR KWL FÜR KANALISIERTEN SCHLAUCH 4-6-8-10-12 AUSGÄNGE Ø 90 MIT MUFFEN, KOMPLETT MIT KALIBRIERKLAPPE MIT REGULIERUNG**

TECHNISCHE EIGENSCHAFTEN

- Aus verzinktem Blech
- Externe Polyethylen-Dämmung st. 3mm
- Erhältlich mit Einlaufkragen Ø150
- Schellen am Ausgang laut Tabelle
- Komplett mit Halterungen für Deckenmontage
- Komplett mit Justierklappe mit Schraubendreherregulierung
- vormontierte gelieferte Plenum

 **MADE IN ITALY**

EXAMPLE PLENUM 8 OUTPUTS

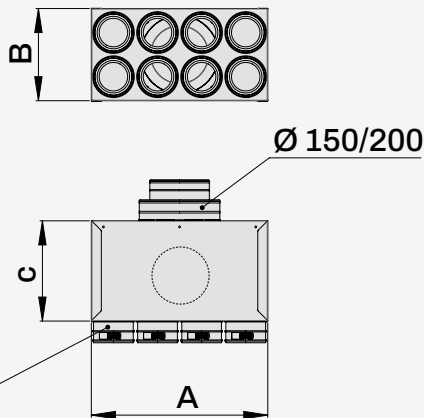

CODE	A	B	C
	[mm]	[mm]	[mm]
ACD600114	230	240	250
ACD600115	350	240	250
ACD600116	465	240	250
ACD600117	580	240	250
ACD600118	700	240	250
ACD600119	230	240	250
ACD600120	350	240	250

Datasheet



CODE	DESCRIPTION	INPUT Ø [mm]	U.M.	 Pieces per box
ACD600114	MVHR INSULATED METAL SHEET PLENUM FOR FLEXIBLE CORRUGATED PIPE Ø90 4 OUTLETS Ø150/200	150 / 200	PCS	1
ACD600115	MVHR INSULATED METAL SHEET PLENUM FOR FLEXIBLE CORRUGATED PIPE Ø90 6 OUTLETS Ø150/200	150 / 200	PCS	1
ACD600116	MVHR INSULATED METAL SHEET PLENUM FOR FLEXIBLE CORRUGATED PIPE Ø90 8 OUTLETS Ø150/200	150 / 200	PCS	1
ACD600117	MVHR INSULATED METAL SHEET PLENUM FOR FLEXIBLE CORRUGATED PIPE Ø90 10 OUTLETS Ø150/200	150 / 200	PCS	1
ACD600118	MVHR INSULATED METAL SHEET PLENUM FOR FLEXIBLE CORRUGATED PIPE Ø90 12 OUTLETS Ø150/200	150 / 200	PCS	1
ACD600119	MVHR INSULATED METAL SHEET PLENUM FOR FLEXIBLE CORRUGATED PIPE Ø90 4 OUTLETS Ø100/125/150	100 / 125 / 150	PCS	1
ACD600120	MVHR INSULATED METAL SHEET PLENUM FOR FLEXIBLE CORRUGATED PIPE Ø90 6 OUTLETS Ø100/125/150	100 / 125 / 150	PCS	1

 **INSULATED DISTRIBUTION PLENUM H160 FOR MVHR FOR FLEXIBLE DUCTED HOSE 6 - 8 OUTLETS Ø75 AND Ø90 WITH SLEEVES COMPLETE WITH CALIBRATION DAMPER WITH ADJUSTMENT**

TECHNICAL SPECIFICATIONS

- Made of galvanised metal sheet.
- Inner insulation made of polyethylene thk. 3 mm.
- Inlet collar Ø150.
- Outlet collars as indicated in the table.
- Complete with brackets for ceiling mounting.
- Sleeves complete with calibration damper which can be adjusted using a screwdriver.
- Plenum box supplied pre-assembled.

 **PLÉNUM DE DISTRIBUTION ISOLÉ H160 POUR VMC POUR CONDUIT GAINABLE FLEXIBLE 6 - 8 SORTIES Ø 75 ET Ø 90 AVEC MANCHONS ÉQUIPÉS AVEC REGISTRE DE RÉGLAGE**

CARACTÉRISTIQUES TECHNIQUES

- Fabriqué en tôle galvanisée.
- Isolation intérieure en polyéthylène ép. 3 mm.
- Collier en entrée Ø150.
- Colliers en sortie selon le tableau.
- Avec supports pour montage au plafond.
- Manchons avec registre d'équilibrage et réglage gradué par tournevis.
- Plénum livré prémonté.

 **ISOLIERTES VERTEILER-PLENUM H160 FÜR KWL FÜR KANALISIERTEN SCHLAUCH 6 - 8 AUSGÄNGE Ø75 UND Ø90 MIT MUFFEN MIT STELLSCHIEBER FÜR DIE EINSTELLUNG**

TECHNISCHE EIGENSCHAFTEN

- Gefertigt aus verzinktem Blech.
- Innendämmung aus Polyethylen, Dicke 3 mm.
- Einlaufkragen Ø150.
- Auslaufkragen gemäß Tabelle.
- Ausgestattet mit Bügeln für die Deckenmontage.
- Muffe mit Stellschieber für die Einstellung mittels Schraubendreher.
- Vormontiert geliefertes Plenum.

NEW

EXAMPLE PLENUM 8 OUTPUTS

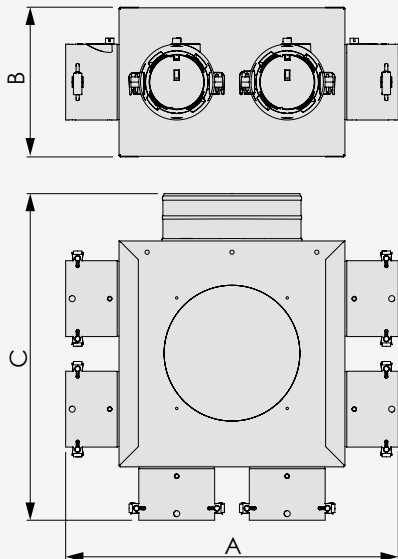

CODE	A	B	C	PESO
	[mm]	[mm]	[mm]	[kg]
ACD600158	355	160	350	1.5
ACD600159	595	160	350	2.5
ACD600160	365	160	355	1.5
ACD600161	605	160	355	2.5



CODE	DESCRIPTION	U.M.	 Pieces per box
ACD600158	DISTRIBUTION PLENUM IN INSULATED SHEET METAL 6 OUTLETS Ø75 WITH INLET Ø150	PCS	1
ACD600159	DISTRIBUTION PLENUM IN INSULATED SHEET METAL 8 OUTLETS Ø75 WITH INLET Ø150	PCS	1
ACD600160	DISTRIBUTION PLENUM IN INSULATED SHEET METAL 6 OUTLETS Ø90 WITH INLET Ø150	PCS	1
ACD600161	DISTRIBUTION PLENUM IN INSULATED SHEET METAL 8 OUTLETS Ø90 WITH INLET Ø150	PCS	1

 **DISTRIBUTION BOX FOR MVHR 90, SUITABLE FOR 4 - 6 - 8 - 10 - 12 FLEXIBLE DUCTED PIPE, WITH SLEEVES AND ADJUSTMENT DAMPER, FOR 4 - 6 - 8 - 10**

TECHNICAL SPECIFICATIONS

- Made of galvanized metal sheet
- Internal insulation in 3 mm thick polyethylene
- With inlet collar with double diameter Ø150 - Ø200
- Outgoing collars as shown in the table
- Complete with brackets
- Sleeves complete with calibration damper with graduated adjustment by screwdriver
- Supplied caps for 4 / 6 / 10 output model
- Box supplied pre-assembled
- Available with collar Ø100 / Ø125 / Ø150

 **BOÎTE DE DISTRIBUTION POUR VMC 90 À TUBE CANALISÉ FLEXIBLE 4 - 6 - 8 - 10 - 12 SORTIES LEGG 75 ET J90 AVEC MANCHONS COMPLETS DE VOLET D'ÉTALONNAGE AVEC RÉGLAGE**

CARACTÉRISTIQUES TECHNIQUES

- Fabriqué en tôle galvanisée
- Isolation interne en polyéthylène de 3 mm d'épaisseur
- Avec col d'entrée avec double diamètre environ Ø150 - Ø200
- Colliers sortants comme indiqué dans le tableau
- Dotés de supports
- Manchons de serrage d'étalonnage avec réglage gradué par tournevis
- Bouchons fournis pour 4/6/10 sorties
- Boîte fournie prémontée
- À la demande disponible avec collerette Ø100 / Ø125 / Ø150

 **VERTEILERKASTEN FÜR KWL 90° FÜR FLEXIBLES KANALROHR 4 - 6 - 8 - 10 - 12 AUSGÄNGE Ø 75 UND Ø 90 MIT JUSTIERKLAPPEN KOMPLETT MIT EINSTELLKLAPPEN**

TECHNISCHE EIGENSCHAFTEN

- Aus verzinktem Blech
- Innenisolierung aus Polyethylen st. 3 mm
- Mit Doppeldurchmesser Ø150 - Ø200
- Schellen am Ausgang laut Tabelle
- Komplett mit Halterungen
- Komplett mit Justierklappe mit Schraubendreherregulierung
- Mitgelieferte Verschlüsse für 4/6/10 Ausgänge
- Kasten vormontiert geliefert
- Auf Wunsch erhältlich mit muffen Ø100 / Ø125 / Ø150

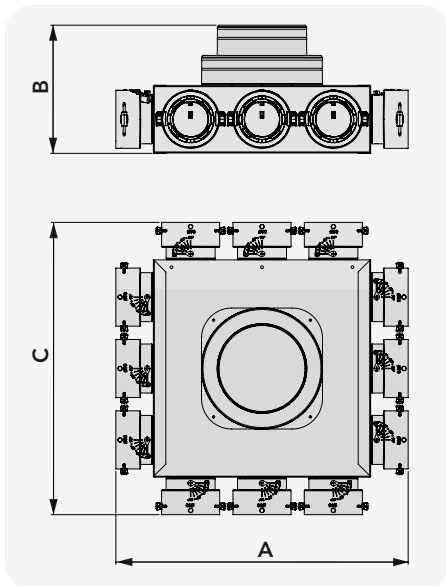

Datasheet

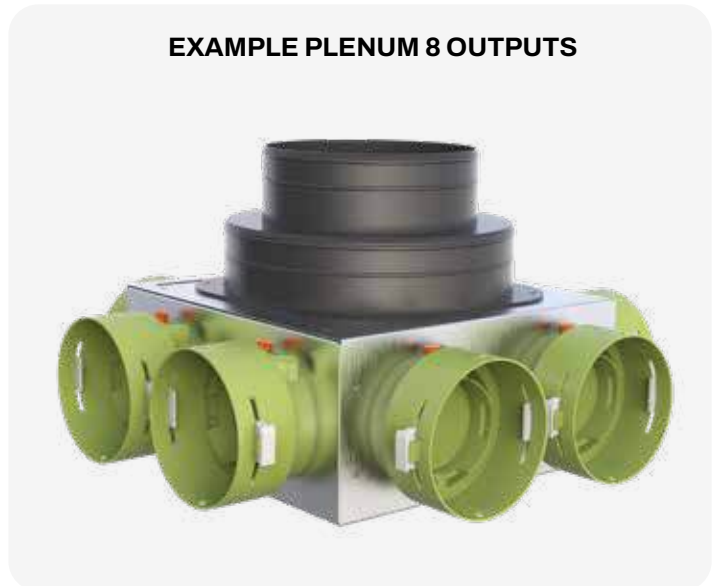

CODE	A	B	C
	[mm]	[mm]	[mm]
ACD600142	234	212	355
ACD600143	300	212	355
ACD600144	355	212	355
ACD600145	473	212	473
ACD600146	473	212	473

CODE	A	B	C
	[mm]	[mm]	[mm]
ACD600137	244	212	365
ACD600138	305	212	365
ACD600139	365	212	365
ACD600140	483	212	483
ACD600141	483	212	483

CODE	DESCRIPTION	U.M.	 Pieces per box
ACD600142	MVHR INSULATED METAL SHEET PLENUM 90° Ø 75 - 4 OUTLETS 150/200	PCS	1
ACD600143	MVHR INSULATED METAL SHEET PLENUM 90° Ø 75 - 6 OUTLETS 150/200	PCS	1
ACD600144	INSULATED METAL SHEET DISTRIBUTION BOX 90° DIAM. 75 - 8 OUTPUTS INPUT 150/200 TS FITTING	PCS	1
ACD600145	MVHR INSULATED METAL SHEET PLENUM 90° Ø 75 - 10 OUTLETS 150/200	PCS	1
ACD600146	MVHR INSULATED METAL SHEET PLENUM 90° Ø 75 - 12 OUTLETS 150/200	PCS	1
ACD600137	MVHR INSULATED METAL SHEET PLENUM 90° Ø 90 - 4 OUTLETS 150/200	PCS	1
ACD600138	MVHR INSULATED METAL SHEET PLENUM 90° Ø 90 - 6 OUTLETS 150/200	PCS	1
ACD600139	MVHR INSULATED METAL SHEET PLENUM 90° Ø 90 - 8 OUTLETS 150/200	PCS	1
ACD600140	MVHR INSULATED METAL SHEET PLENUM 90° Ø 90 - 10 OUTLETS 150/200	PCS	1
ACD600141	MVHR INSULATED METAL SHEET PLENUM 90° Ø 90 - 12 OUTLETS 150/200	PCS	1



"GALATEA" STAINLESS STEEL GRILLE

TECHNICAL SPECIFICATIONS

- Made of brushed stainless steel
- Fastening by means of screws



"GALATEA" GRILLE INOX

CARACTÉRISTIQUES TECHNIQUES

- Fabriqué en acier inoxydable brossé
- Fixation au moyen de vis



"GALATEA" EDELSTAHLGITTER

TECHNISCHE EIGENSCHAFTEN

- Aus satiniertem Edelstahl
- Befestigung mittels Schrauben



MADE IN ITALY

Possibility of customization

CODE	DESCRIPTION	EXTERNAL DIMENSIONS [mm]	AIRFLOW [M ³ /H]	U.M.	Pieces per box
ACD600055	STAINLESS STEEL GRILLE "GALATEA" 200x100	340 X 190	60	PCS	1
ACD600056	STAINLESS STEEL GRILLE "GALATEA" 300x100	440 x 190	75	PCS	1
30100840	STAINLESS STEEL GRILLE "GALATEA" 330X180	240 X 140	40	PCS	1
30100860	STAINLESS STEEL GRILLE "AURORA" 430X180	340 x 140	50	PCS	1

Datasheet



"VANESSA" STAINLESS STEEL GRILLE

TECHNICAL SPECIFICATIONS

- Made of brushed stainless steel
- Fastening by means of screws



"VANESSA" GRILLE INOX

CARACTÉRISTIQUES TECHNIQUES

- Fabriqué en acier inoxydable brossé
- Fixation au moyen de vis



"VANESSA" EDELSTAHLGITTER

TECHNISCHE EIGENSCHAFTEN

- Aus satiniertem Edelstahl
- Befestigung mittels Schrauben



MADE IN ITALY

Possibility of customization

CODE	DESCRIPTION	EXTERNAL DIMENSIONS [mm]	AIRFLOW [M ³ /H]	U.M.	Pieces per box
ACD600053	STAINLESS STEEL GRILLE "VANESSA" 200x100	240 X 140	40	PCS	1
ACD600054	STAINLESS STEEL GRILLE "VANESSA" 300x100	340 x 140	50	PCS	1
30100800	STAINLESS STEEL GRILLE "VANESSA" 330X180	340 X 190	60	PCS	1
30100820	STAINLESS STEEL GRILLE "VANESSA" 430X180	440 x 190	75	PCS	1

Datasheet



"IRIDE" STAINLESS STEEL GRILLE

TECHNICAL SPECIFICATIONS

- Made of brushed stainless steel
- Fastening by means of screws



"IRIDE" GRILLE INOX

CARACTÉRISTIQUES TECHNIQUES

- Fabriqué en acier inoxydable brossé
- Fixation au moyen de vis



"IRIDE" EDELSTAHLGITTER

TECHNISCHE EIGENSCHAFTEN

- Aus satiniertem Edelstahl
- Befestigung mittels Schrauben



MADE IN ITALY

Possibility of customization

CODE	DESCRIPTION	EXTERNAL DIMENSIONS [mm]	AIRFLOW [M ³ /H]	U.M.	Pieces per box
ACD600057	STAINLESS STEEL GRILLE "IRIDE" 200x100	340 X 190	60	PCS	1
ACD600058	STAINLESS STEEL GRILLE "IRIDE" 300x100	440 x 190	75	PCS	1
30100920	STAINLESS STEEL GRILLE "IDIDE" 330X180	240 X 140	40	PCS	1
30100940	STAINLESS STEEL GRILLE "IRIDE" 430X180	340 x 140	50	PCS	1

Datasheet



 **"GINEVRA" GRID IN WHITE PAINTED STEEL**

TECHNICAL SPECIFICATIONS

- Made of electro-galvanised metal sheet
- Painting white RAL 9016
- Fastening by means of screws

 **"GINEVRA" GRILLE EN ACIER PEINT EN BLANC**

CARACTÉRISTIQUES TECHNIQUES

- En tôle électro-galvanisée
- Peinture blanche RAL 9016
- Fixation au moyen de vis

 **"GINEVRA" GITTER AUS WEISS LACKIERTEM STAHL**

TECHNISCHE EIGENSCHAFTEN

- Aus elektro-galvanisiertem Blech
- Lackierung weiß RAL 9016
- Befestigung mittels Schrauben

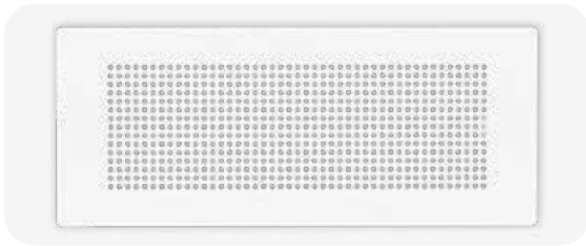

 **MADE IN ITALY**

CODE	DESCRIPTION	EXTERNAL DIMENSIONS [mm]	AIRFLOW [M ³ /H]	U.M.	 Pieces per box
ACD600071	WHITE GRILLE "GINEVRA" 200x100	240 X 140	40	PCS	1
ACD600072	WHITE GRILLE "GINEVRA" 300x100	340 x 140	50	PCS	1
ACD600073	WHITE GRILLE "GINEVRA" 300x150	340 X 190	60	PCS	1
ACD600074	WHITE GRILLE "GINEVRA" 400x150	440 x 190	75	PCS	1

Datasheet



 **"LUCINA" INTAKE GRILLE**

TECHNICAL SPECIFICATIONS

- Max intake capacity 50 m³/h
- 360° adjustable slats

 **"LUCINA" GRILLE DE RÉCUPÉRATION**

CARACTÉRISTIQUES TECHNIQUES

- Capacité de récupération max 50 m³/h
- Lames réglables à 360°

 **"LUCINA" ABLUFTGITTER**

TECHNISCHE EIGENSCHAFTEN

- Max. Aufnahmekapazität 50 m³/h
- 360° verstellbare Lamellen

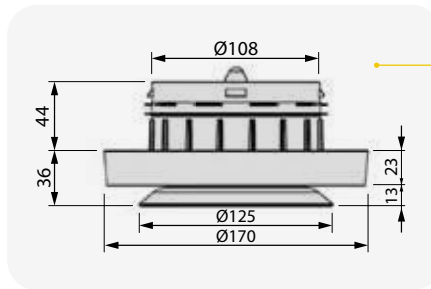

CONNECTION

- 30100140
- 30100150
- 30100220
- 30100240
- 30101070

Datasheet



CODE	DESCRIPTION	U.M.	 Pieces per box
30100300	LUCINA" OUTFLOW GRILLE	PCS	1

 **"CLOE" AIR DELIVERY/INTAKE GRILLE**

TECHNICAL SPECIFICATIONS

- Max intake capacity 50 m³/h

 **"CLOE" GRILLE DE REFOULEMENT/EXTRACTION**

CARACTÉRISTIQUES TECHNIQUES

- Capacité de récupération max 50 m³/h

 **"CLOE" VORLAUF- / RÜCK-KLAUFGITTER**

TECHNISCHE EIGENSCHAFTEN

- Max. Aufnahmekapazität 50 m³/h

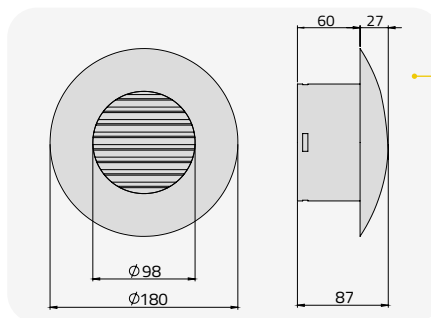

CONNECTION

- 30100140
- 30100150
- 30100220
- 30100240
- 30101070

Datasheet



CODE	DESCRIPTION	U.M.	 Pieces per box
30100310	"CLOE" INTAKE GRILLE	PCS	1



 **CEILING / WALL / FLOOR
PLENUM**

TECHNICAL SPECIFICATIONS

- Made of electro-galvanised metal sheet
- Ready for side, top and rear pipe entry.
- Supplied including air inlet flexible hose fitting.
- Suitable for Vanessa, Galatea, Iride grilles.

 **PLÉNUM PLAFOND/MUR/SOL**

CARACTÉRISTIQUES TECHNIQUES

- Fabriquée en tôle électro-galvanisée
- Prédisposé pour l'entrée des tubes latéraux, supérieurs et arrière.
- Livré complet avec raccord de tuyau d'entrée d'air.
- Convient pour les grilles Vanessa, Galatea, Iride.

 **PLENUM DECKE / WAND /
BODEN**

TECHNISCHE EIGENSCHAFTEN

- Aus elektro-galvanisiertem Blech
- Vorbereitet für den seitlichen, oberen und hinteren Rohreinlass.
- Lieferung komplett mit Lufteinlassschlauchverschraubung.
- Geeignet für die Gitter Vanessa, Galatea, Iride.

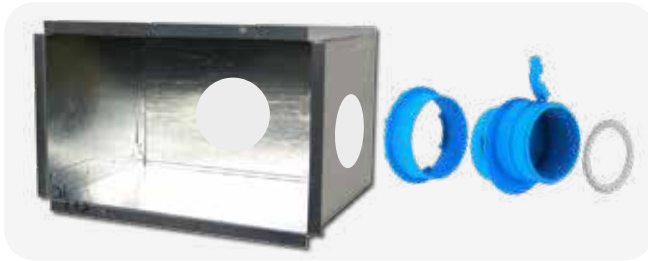

 **MADE IN ITALY**

Insulated plenum

Possibility of input on 3 sides

Datasheet



CODE	DESCRIPTION	EXTERNAL DIMENSIONS [mm]	DEPTH [mm]	U.M.	 Pieces per box
30100600	PLENUM CEILING/WALL/FLOOR 330X180 1 ATTACHMENT D.75	310 x 160	120	PCS	1
30100620	PLENUM CEILING/WALL/FLOOR 330X180 1 ATTACHMENT D.90	310 x 160	120	PCS	1
30100640	PLENUM CEILING/WALL/FLOOR 330X180 1 ATTACHMENT D.75	410 x 160	120	PCS	1
30100660	PLENUM CEILING/WALL/FLOOR 430x180 1 ATTACHMENT D.90	410 x 160	120	PCS	1
30100680	PLENUM CEILING/WALL/FLOOR 430x180 2 ATTACHMENT D.75	410 x 160	120	PCS	1
30100700	PLENUM CEILING/WALL/FLOOR 430x180 2 ATTACHMENT D.90	410 x 160	120	PCS	1
ACD600039	PLENUM CEILING/WALL/FLOOR Ø75 FOR GRILLES 200x100	210 x 110	120	PCS	1
ACD600040	PLENUM CEILING/WALL/FLOOR Ø92 FOR GRILLES 200x100	210 x 110	120	PCS	1
ACD600041	PLENUM CEILING/WALL/FLOOR Ø75 FOR GRILLES 300x100	310 x 110	120	PCS	1
ACD600042	CEILING/WALL/FLOOR PLENUM Ø92 FOR GRILLE 300x100	310 x 110	120	PCS	1

 **CEILING / WALL / FLOOR
TELESCOPIC PLENUM**

TECHNICAL SPECIFICATIONS

- Made of electro-galvanised metal sheet
- Ready for side, top and rear pipe entry.
- Supplied including air inlet flexible hose fitting.
- Suitable for Vanessa, Galatea, Iride grilles.
- Telescopic brackets supplied

 **PLÉNUM PLAFOND/MUR/SOL
TÉLESCOPIQUE**

CARACTÉRISTIQUES TECHNIQUES

- Fabriquée en tôle électro-galvanisée
- Prédisposé pour l'entrée des tubes latéraux, supérieurs et arrière.
- Livré complet avec raccord de tuyau d'entrée d'air.
- Convient pour les grilles Vanessa, Galatea, Iride.
- Supports télescopiques fournis

 **TELESKOPISCHES PLENUM
DECKE / WAND / BODEN**

TECHNISCHE EIGENSCHAFTEN

- Aus elektro-galvanisiertem Blech
- Vorbereitet für den seitlichen, oberen und hinteren Rohreinlass.
- Lieferung komplett mit Lufteinlassschlauchverschraubung.
- Geeignet für die Gitter Vanessa, Galatea, Iride.
- Teleskopische Bügel mitgeliefert



 **MADE IN ITALY**

Insulated plenum

Datasheet



CODE	DESCRIPTION	EXTERNAL DIMENSIONS [mm]	DEPTH [mm]	U.M.	 Pieces per box
ACD600043	TELESCOPIC PLENUM CEILING/WALL/FLOOR Ø75 FOR GRILLES 200x100	210 x 115	120	PCS	1
ACD600044	TELESCOPIC PLENUM CEILING/WALL/FLOOR Ø92 FOR GRILLES 200x100	210 x 115	120	PCS	1
ACD600045	TELESCOPIC PLENUM CEILING/WALL/FLOOR Ø75 FOR GRILLES 300x100	310 x 115	120	PCS	1
ACD600046	TELESCOPIC PLENUM CEILING/WALL/FLOOR Ø92 FOR GRILLES 300x100	310 x 115	120	PCS	1
ACD600047	TELESCOPIC PLENUM CEILING/WALL/FLOOR Ø75 FOR GRILLES 300x150	310 x 165	120	PCS	1
ACD600048	TELESCOPIC PLENUM CEILING/WALL/FLOOR Ø92 FOR GRILLES 300x150	310 x 165	120	PCS	1
ACD600049	TELESCOPIC PLENUM CEILING/WALL/FLOOR Ø75 FOR GRILLES 400x150	410 x 165	120	PCS	1
ACD600050	TELESCOPIC PLENUM CEILING/WALL/FLOOR Ø92 FOR GRILLES 400x150	410 x 165	120	PCS	1
ACD600051	TELESCOPIC PLENUM CEILING/WALL/FLOOR 2xØ75 FOR GRILLES 400x150	410 x 165	120	PCS	1
ACD600052	TELESCOPIC PLENUM CEILING/WALL/FLOOR 2xØ92 FOR GRILLES 400x150	410 x 165	120	PCS	1

GRILLES WITH CONCEALED FRAME FOR PLASTERBOARD

TECHNICAL SPECIFICATIONS

- Made of anodised aluminium
- Air delivery and intake
- Grille with concealed frame and pull-out central zone
- Installation on frame support by means of screws
- G2 Filter
- Plenum for wall installation in plasterboard in electro-galvanised metal sheet prepared for Ø75 and Ø92 collars (separate)

GRILLES AVEC CADRE ESCAMOTABLE POUR PLAQUE DE PLÂTRE

CARACTÉRISTIQUES TECHNIQUES

- Fabriqué en aluminium anodisé
- Livraison et récupération d'air
- Grille avec cadre rétractable et partie centrale amovible
- Installation sur support de cadre au moyen de vis
- Filtre G2
- Plénum pour installation murale en plaque de plâtre en tôle électrozinguée préparée pour les colliers Ø75 et Ø92 (séparément)

GITTER MIT VERDECKTEM RAHMEN FÜR GIPSKARTON-PLATTEN

TECHNISCHE EIGENSCHAFTEN

- Aus eloxiertem Aluminium
- Einlass und Abluft
- Gitter mit einziehbarem Rahmen und abnehmbarem Mittelteil
- Installation auf Rahmenhalterung mit Schrauben
- Filter G2
- Plenum für Gipskarton-Wandinstallation aus galvanisch verzinktem Blech, vorbereitet für Ø75- und Ø92-Schellen (separat)

Model IRIS



Model ATENA

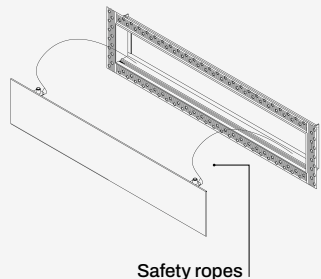

Safety ropes

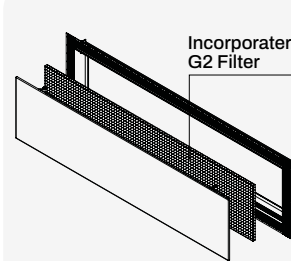

Incorporate G2 Filter

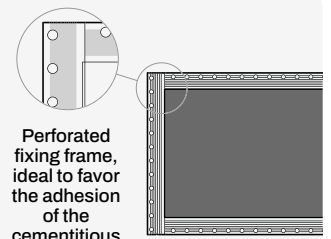

Perforated fixing frame, ideal to favor the adhesion of the cementitious material

CODE	DESCRIPTION	EXTERNAL DIMENSIONS [mm]	AIRFLOW [m³/h]	U.M.	Pieces per box
ACC600044	GRILLE MODEL ATENA 200x100	200 x 100	30	PCS	1
ACC600045	GRILLE MODEL ATENA 300x100	300 x 100	40	PCS	1
ACC600049	GRILLE MODEL IRIS 200x100	200 x 100	50	PCS	1
ACC600050	GRILLE MODEL IRIS 300x100	300 x 100	80	PCS	1

Datasheet



METAL SHEET PLENUM FOR ATHENA AND IRIS GRILLES PLASTERBOARD INSTALLATION

TECHNICAL SPECIFICATIONS

- Made of anodised aluminium
- Air delivery and intake
- Grille with concealed frame and pull-out central zone
- Installation on frame support by means of screws
- G2 Filter
- Plenum for wall installation in plasterboard in electro-galvanised metal sheet prepared for Ø75 and Ø92 collars (separate)

PLÉNUM EN TÔLE POUR GRILLES ATENA ET IRIS EN PLAQUE DE PLÂTRE

CARACTÉRISTIQUES TECHNIQUES

- Fabriqué en aluminium anodisé
- Livraison et récupération d'air
- Grille avec cadre rétractable et partie centrale amovible
- Installation sur support de cadre au moyen de vis
- Filtre G2
- Plénum pour installation murale en plaque de plâtre en tôle électrozinguée préparée pour les colliers Ø75 et Ø92 (séparément)

PLENUM AUS BLECH FÜR DIE INSTALLATION VON ATENA-UND IRIS-GITTERN AUF GIPSKARTON-PLATTEN

TECHNISCHE EIGENSCHAFTEN

- Aus eloxiertem Aluminium
- Einlass und Abluft
- Gitter mit einziehbarem Rahmen und abnehmbarem Mittelteil
- Installation auf Rahmenhalterung mit Schrauben
- Filter G2
- Plenum für Gipskarton-Wandinstallation aus galvanisch verzinktem Blech, vorbereitet für Ø75- und Ø92-Schellen (separat)

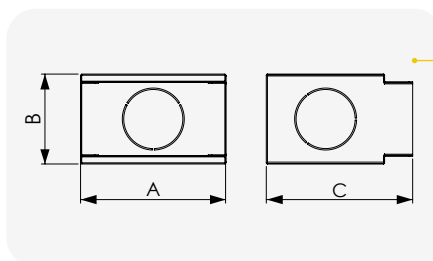

FOR COLLARS

See page 91
Codes: 30100120,
30100200

CODE	DESCRIPTION	A [mm]	B [mm]	C [mm]	U.M.	Pieces per box
ACD600085	METAL SHEET PLENUM FOR ATHENA AND IRIS GRILLES PLASTERBOARD INSTALLATION 200x100	210	130	210	PCS	1
ACD600086	METAL SHEET PLENUM FOR ATHENA AND IRIS GRILLES PLASTERBOARD INSTALLATION 300x100	310	130	210	PCS	1

Datasheet





PLENUM IN PS PLASTIC FOR MVHR

TECHNICAL SPECIFICATIONS

- Plenum made of PS plastic (polystyrene)
- Fixing can be performed on both plasterboard and masonry with a minimum depth of 100 mm up to 150 mm
- Fixing on plasterboard by self-tapping screws on the 4 side fins
- With built-in bubble
- Possibility for spirit level installation work site cover or inside Airbox Box
- Protective cover plaster complete with extraction handle
- No. 4 metal brackets 80 x 80 for rear fixing included
- Sleeves complete with calibration damper with graduated adjustment by screwdriver
- Complete hose clamps
- Possibility to break side flaps for wall insertion
- Choice of up to 4 grille models in ABS plastic RAL 9016 finish
- Possibility of up to 5 inlets for Ø 75 and Ø 90 sleeves



PLÉNUM EN PLASTIQUE PS POUR VMC

CARACTÉRISTIQUES TECHNIQUES

- Plénum en plastique PS (polystyrène)
- La fixation peut être effectuée sur des plaques de plâtre ou de maçonnerie d'une profondeur minimale de 100 mm jusqu'à 150 mm
- Fixation sur plaques de plâtre au moyen de vis autotaraudeuses sur les 4 ailettes latérales
- Avec bulle intégrée
- Possibilité d'installation bulle aussi bien sur couvercle de chantier aussi bien à l'intérieur de la boîte Airbox
- Couvercle de protection en plâtre avec poignée d'extraction
- N° 4 supports en métal 80 x 80 pour fixation arrière fournie.
- Manchons de serrage d'étalonnage avec réglage gradué par tournevis
- Manchons complets de butée
- Possibilité de rupture ailettes latérales pour l'insertion en maçonnerie



PLENUM AUS PS KUNSTSTOFF FÜR KWL

TECHNISCHE EIGENSCHAFTEN

- Plenum aus PS-Kunststoff (Polystyrol)
- Die Befestigung kann sowohl auf Gipskarton als auch auf Mauerwerk mit einer Mindestdiefe von 100 mm bis 150 mm erfolgen
- Befestigung auf Gipskarton mit selbstschneidenden Schrauben an den 4 Seitenflügeln
- Mit integrierter Libelle
- Möglichkeit der installation der wasserwaage sowohl auf der baustellenabdeckung als auch im inneren des Airbox gehäuses
- Schutzdeckel mit Ausziehgriff
- Nr. 4 Bügel aus Metall 80 x 80 zur hinteren befestigung im Lieferumfang enthalten
- Komplett mit Justierklappe mit Schraubendreherregulierung
- Hülsen komplett mit Schlauchklammer
- Möglichkeit des Bruchs der seitenklappen aufgrund der Einführung in das Mauerwerk

The new Plenum in PS plastic for MVHR is the **ideal solution for an efficient mechanical controlled ventilation (MVHR) system at home or in the office. Airbox is designed for use with a broad range of mechanical controlled ventilation units**, allowing easy installation and perfect integration in your existing ventilation system. Its compact size and ergonomic design make it ideal for different types of residential and commercial environments.

The MVHR hose can be connected at the rear, top or side. **Includes adjustment dampers and a wide range of accessories for quick and easy installation.** Complete the kit with a choice of steel nozzle painted white, **possibility to choose from the following models: Gemini - Virgo - Aries - Taurus**

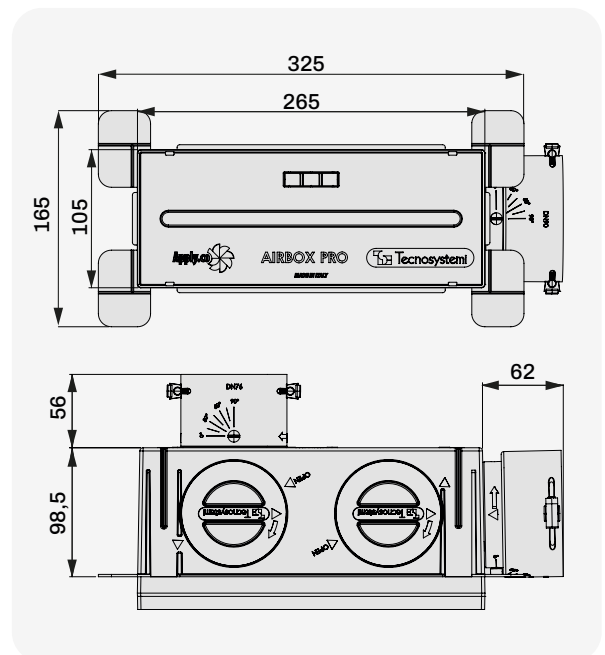
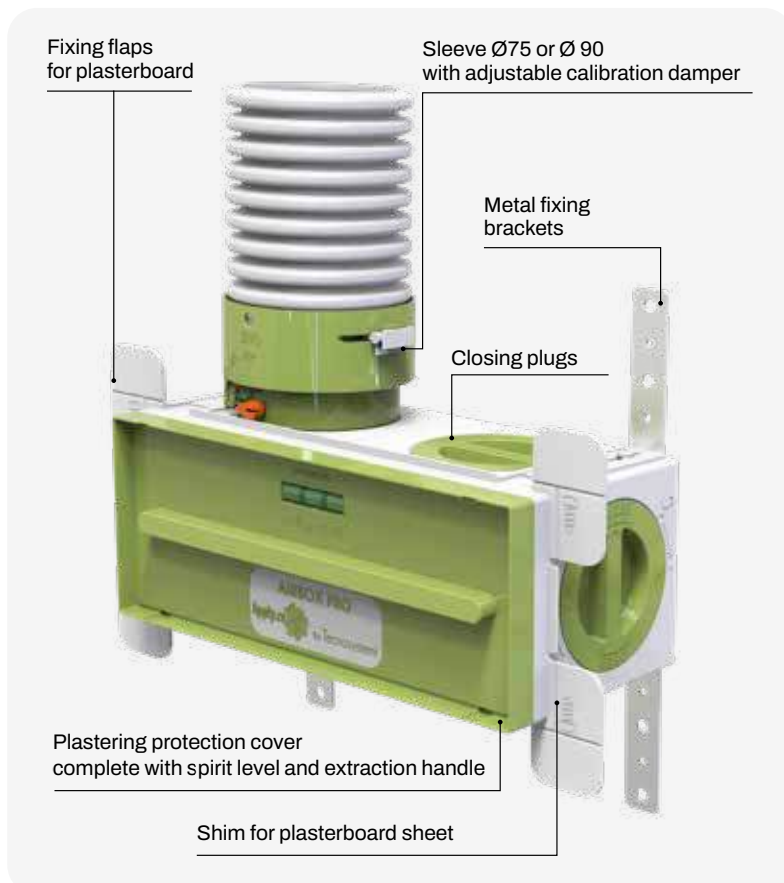



Fixing example with self-tapping screws on 4 side flaps on plasterboard



Fixing example with telescopic rear brackets on plasterboard



Fixing example on masonry

CALIBRATION DAMPER ROTATION 0° - 30° - 60° - 90°



0°



30°



60°



90°

**EXAMPLE INSTALLATION
"GEMINI" GRILLE**



THE Ø75 KIT INCLUDES

- Airbox Pro Plenum
- N. 1 sleeve diameter 75
- N. 1 gasket diameter 75
- N. 1 plenum cover with spirit level
- N. 4 caps
- Brackets kit (4 pcs. + 4 screws)

THE Ø90 KIT INCLUDES

- Airbox Pro Plenum
- N. 1 sleeve diameter 90
- N. 1 gasket diameter 90
- N. 1 plenum cover with spirit level
- N. 4 caps
- Brackets kit (4 pcs. + 4 screws)

CHOICE OF FINISHING GRILLE

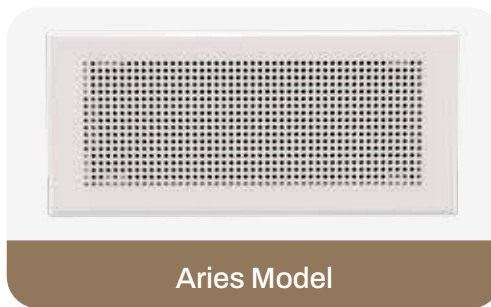
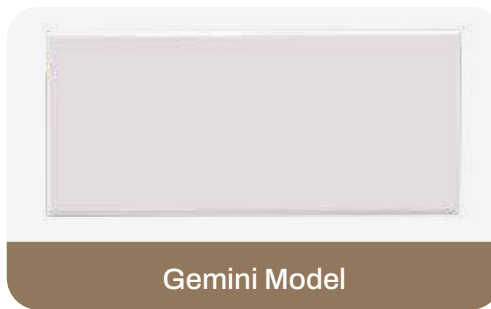

CODE	DESCRIPTION	U.M.	 Pieces per box
ACD600088	MVHR PLENUM IN POLYSTYRE WITH SLEEVE FOR PIPE Ø75 - "AIRBOX PRO"	PCS	1
ACD600092	MVHR PLENUM IN POLYSTYRE WITH SLEEVE FOR PIPE Ø90 - "AIRBOX PRO"	PCS	1
ACD600089	SLEEVE KIT FOR PIPE Ø75	KIT	1
ACD600090	SLEEVE KIT FOR PIPE Ø90	KIT	1
ACD600157	SET OF CAPS FOR MVHR	KIT	1

Datasheet



CODE	DESCRIPTION	EXTERNAL DIMENSIONS [mm]	AIRFLOW [m³/h]	U.M.	 Pieces per box
ACC600089	DECORATIVE GRILL - Model GEMINI	L. 303 x H. 133	40	PCS	1
ACC600090	DECORATIVE GRILL - Model VIRGO	L. 303 x H. 133	60	PCS	1
ACC600091	DECORATIVE GRILL - Model ARIES	L. 303 x H. 133	50	PCS	1
ACC600092	DECORATIVE GRILL - Model TAURUS	L. 303 x H. 133	70	PCS	1
ACC600093	FILTER KIT FOR AESTHETIC GRID TAURUS, VIRGO, ARIES 253X91X8 MM (PACK OF 5 PIECES)	-	-	KIT	1

Datasheet





THROUGH CEILING PLENUM

TECHNICAL SPECIFICATIONS

- Made of electro-galvanised metal sheet
- Fastening brackets supplied
- Air intake collar Ø 125 / 150 supplied (not installed)
- Air output collar for MVHR duct



PLENUM DE PLAFOND PASSANT

CARACTÉRISTIQUES TECHNIQUES

- Fabriqué en tôle électro-galvanisée
- Supports de fixation fournis
- Collier d'entrée d'air Ø 125 / 150 fourni (non installé)
- Collier de sortie d'air pour conduit VMC



DURCH DIE DECKE GEHENDES PLENUM

TECHNISCHE EIGENSCHAFTEN

- Aus elektro-galvanisiertem Blech
- Befestigungsbügel mitgeliefert
- Lufteinlassschelle Ø 125 / 150 (nicht installiert)
- Luftauslassschelle für WRG-Lüftung-Kanäle

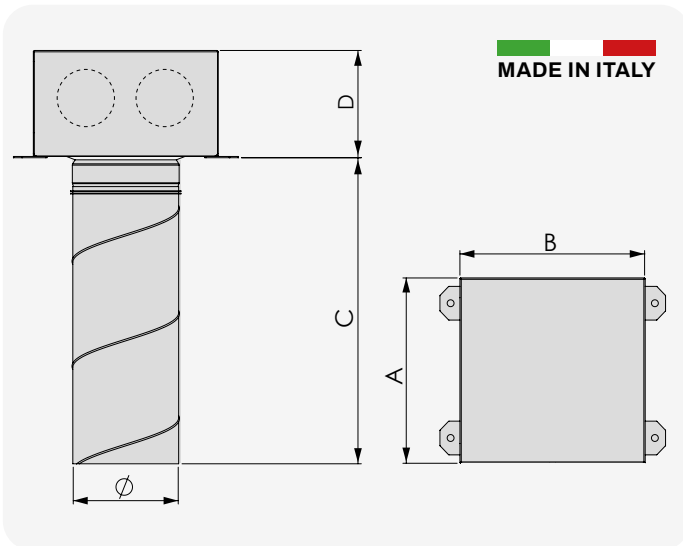

THE KIT INCLUDES

- N. 1 through ceiling plenum
- N. 1 oval collar for plenum C3 Ø 125 / 150
- N. 4 mounting brackets plenum
- N. 1 sleeve billet Ø 125 l. 33 cm
- N. 1 spiral metallic rigid circular duct Ø 125 mm L. 33 cm
- N. 1 flexible hose connector Ø 92 mm (only for cod. ACD600083)
- N. 2 flexible hose connector Ø 75 mm (only for cod. ACD600084)



DIMENSIONS [mm]					
MODEL	A	B	C	D	Ø
ACD600083	220	325	330	130	125
ACD600084	220	325	330	130	125

CODE	DESCRIPTION	U.M.	Pieces per box
ACD600083	THROUGH CEILING PLENUM PREPARED FOR 1 OVAL ENTRANCE Ø125/150 + 1 ENTRANCE Ø92	PCS	1
ACD600084	THROUGH CEILING PLENUM PREPARED FOR 1 OVAL ENTRANCE Ø125/150 + 2 ENTRANCE Ø75	PCS	1

Datasheet



 **RESIDENTIAL EXTRACTOR TOWER**

TECHNICAL SPECIFICATIONS

- Max operating temperature: +50°C
- Weatherproof
- Made of metal finished with polymer paint
- Protection rating: IP X4
- Supply voltage: 230 V AC - 50 Hz

 **TOUR D'EXTRACTION RÉSIDENTIELLE**

CARACTÉRISTIQUES TECHNIQUES

- Température maximale de fonctionnement : +50°C
- Résistant aux intempéries
- Fabriqué en métal fini avec de la peinture polymère
- Degré de protection : IP X4
- Tension d'alimentation : 230 Vca - 50 Hz

 **ABLUFFTTURM FÜR WOHN-GEBÄUDE**

TECHNISCHE EIGENSCHAFTEN

- Max. Betriebstemperatur: +50°C
- Wetterfest
- Aus Metall mit Polymerfarbe
- Schutzart: IP X4
- Netzspannung: 230 V AC - 50 Hz

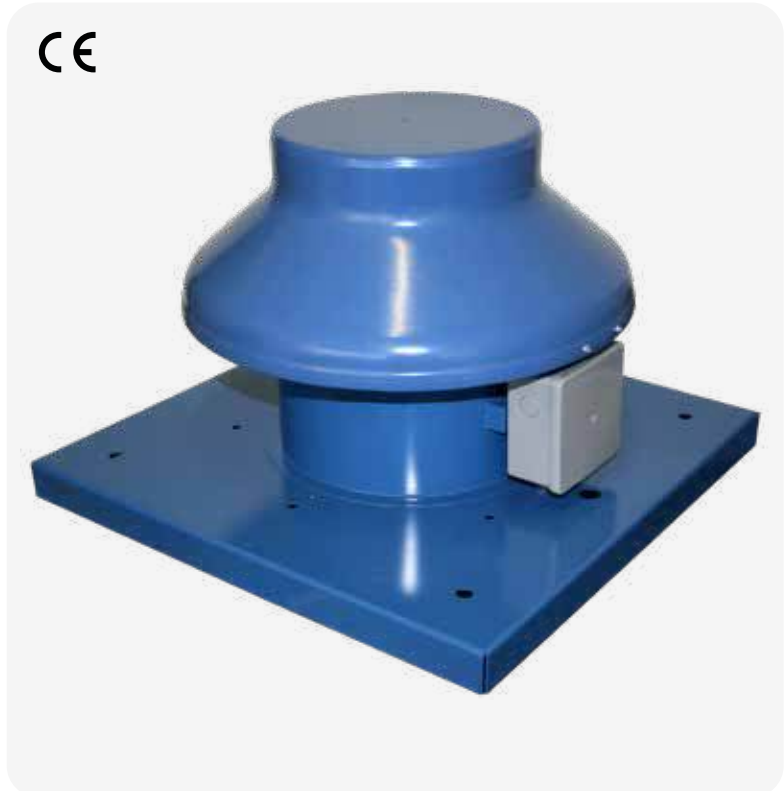
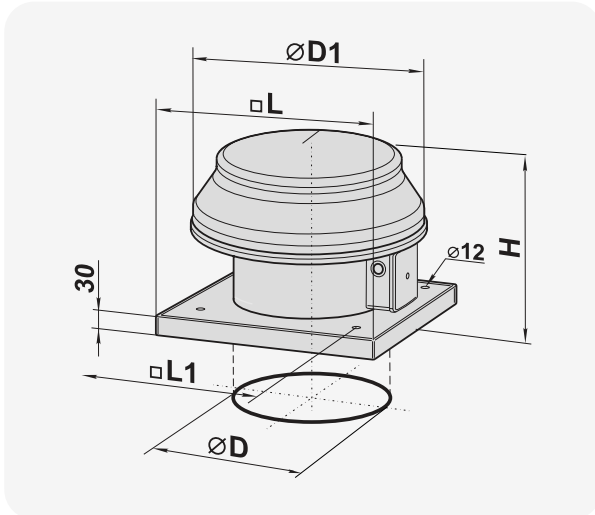

DIMENSIONS [mm]					
MODEL	ØD	ØD1	H	L	L1
200	208	345	280	425	330
250	262	405	300	425	330
315	315	555	380	585	450

TECHNICAL DATA			
MODEL	200	250	315
POWER SUPPLY [V]	230	230	230
FREQUENCY [Hz]	50	50	50
POWER [W]	43	68	110
ABSORBED CURRENT [A]	0,28	0,48	0,75
AIR FLOW RATE [m³/h]	405	1070	1700
RPM	1300	1300	1300
MAX SOUND LEVEL [dB(A)]	32	48	54
OPERATING TEMPERATURE MAX [°C]	40	40	40
PROTECTION RATING [IP]	X4	X4	X4
WEIGHT [kg]	4,9	6,8	9,2

CODE	DESCRIPTION	U.M.	 Pieces per box
11104110	RESIDENTIAL ROOF EXTRACTOR 200	PCS	1
11104120	RESIDENTIAL ROOF EXTRACTOR 250	PCS	1
11104130	RESIDENTIAL ROOF EXTRACTOR 315	PCS	1



 **MIXED FLOW IN-LINE FAN**

TECHNICAL SPECIFICATIONS

- Made of ABS
- Easy to install and inspect
- 2 speeds
- Operable via ON / OFF switch (not supplied)
- Recommended for kitchens, bathrooms, offices, shops

 **VENTILATEUR EN LIGNE À FLUX MIXTE**

CARACTÉRISTIQUES TECHNIQUES

- Fabriqué en ABS
- Facile à installer et à inspecter
- 2 vitesses
- Actionnable via l'interrupteur marche/arrêt (non fourni)
- Recommandé pour les cuisines, salles de bains, bureaux, magasins

 **INLINE-VENTILATOR MIT GEMISCHTER STRÖMUNG**

TECHNISCHE EIGENSCHAFTEN

- Aus ABS
- Einfache Montage und Wartung
- 2 Geschwindigkeiten
- Bedienung über EIN / AUS-Schalter (nicht mitgeliefert)
- Empfohlen für Küchen, Bäder, Büros, Geschäfte

CE

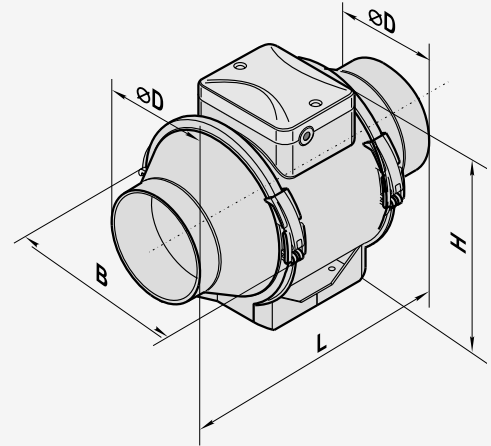

Fastening support included

Quick release system for easy installation and inspection

TECHNICAL DATA

MODEL	Ø 100		Ø 125		Ø 150		Ø 200		Ø 250	
POWER SUPPLY [V]	230									
FREQUENCY [Hz]	50									
SPEED	min.	max.	min.	max.	min.	max.	min.	max.	min.	max.
POWER [W]	21	33	23	37	30	60	76	108	125	177
CURRENT [A]	0,11	0,21	0,18	0,27	0,17	0,27	0,34	0,48	0,54	0,79
AIR FLOW [m³/h]	145	187	220	280	405	520	830	1040	1110	1400
RPM	2180	2385	1950	2455	1680	2460	1915	2380	1955	2440
NOISE LEVEL AT 3 m [dB(A)]	27	36	28	37	33	44	45	52	47	55
OPERATING TEMPERATURE [°C]	60									
PROTECTION GRADE [IP]	X4									

CODE	DESCRIPTION	ØD [mm]	B [mm]	H [mm]	L [mm]	WEIGHT [kg]	U.M.	Pieces per box
30360150	MIXED-FLOW FANS - "IN LINEA" MODEL 100	96	167	190	246	1,4	PCS	1
30360160	MIXED-FLOW FANS - "IN LINEA" MODEL 125	123	167	190	246	1,8	PCS	1
30360170	MIXED-FLOW FANS - "IN LINEA" MODEL 150	146	223	250	295	3,2	PCS	1
30360250	MIXED-FLOW FANS - "IN LINEA" MODEL 200	199	239	261	295,5	4	PCS	1
30360260	MIXED-FLOW FANS - "IN LINEA" MODEL 250	247	287	323	383	7,8	PCS	1

Datasheet



IN-LINE CIRCULAR DUCT FAN, SINGLE PHASE AC CENTRIFUGE

TECHNICAL SPECIFICATIONS

- Made of ABS
- Installation protection rating IPX4
- Axial assembly on pipe

VENTILATEUR EN LIGNE DE CONDUIT CIRCULAIRE, CENTRIFUGEUSE AC MONOPHASÉE

CARACTÉRISTIQUES TECHNIQUES

- Fabriqué en ABS
- Degré de protection de l'installation IPX4
- Montage axial sur tube

INLINE-VENTIL MIT RUNDEM KANAL, EINPHASIGES AC ZENTRIFUGUM

TECHNISCHE EIGENSCHAFTEN

- Aus ABS
- Schutzart IPX4
- Axial Montage auf Rohr

The in-line extraction fan is ideal for ventilation in rigid and/or flexible circular ducts for the delivery or expulsion of air in domestic rooms, offices, shops and bathrooms.

It is made of plastic material to reduce the formation of condensate and the already low noise of the fan at both minimum and maximum speed. The included support allows installation both vertically and horizontally, on the floor, wall or ceiling.

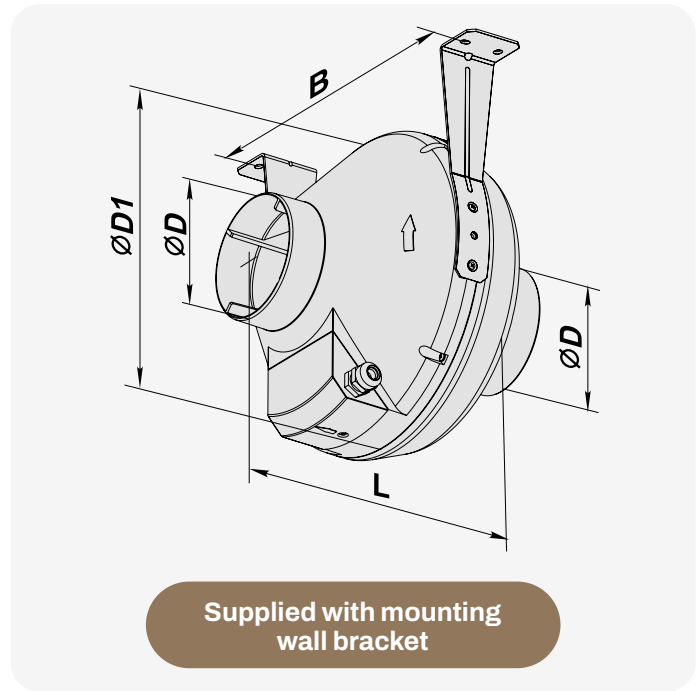

TECHNICAL DATA

MODEL	ACC500009	ACC500010	ACC500011	ACC500012	ACC500013
ELECTRICAL POWER INPUT (W)	80	79	80	107	173
CURRENT (A)	0,34	0,34	0,35	0,47	0,76
MAXIMUM FLOW RATE (m ³ /h)	250	355	460	780	1080
ROTATION FREQUENCY (rpm)	2820	2800	2725	2660	2090
POWER SUPPLY [W]	230V +/-10% single-phase				
FREQUENCY	50 Hz				
INSULATION CLASS	Class II				
PROTECTION RATING	IPX4				
MAXIMUM TRANSPORTED AIR TEMPERATURE (°C)	-25 ÷ +60				

CODE	DESCRIPTION	ØD [mm]	ØD1 [mm]	B [mm]	L [mm]	WEIGHT [kg]	U.M.	Pieces per box
ACC500009	FAN FOR CIRCULAR DUCTS Ø100 - "IN LINEA"	100	250	270	230	2,01	PCS	1
ACC500010	FAN FOR CIRCULAR DUCTS Ø125 - "IN LINEA"	125	250	270	220	2,20	PCS	1
ACC500011	FAN FOR CIRCULAR DUCTS Ø150/160 - "IN LINEA"	200	340	354	276	3,00	PCS	1
ACC500012	FAN FOR CIRCULAR DUCTS Ø200 - "IN LINEA"	150/160	300	310	286	2,45	PCS	1
ACC500013	FAN FOR CIRCULAR DUCTS Ø250 - "IN LINEA"	250	340	354	265	4,30	PCS	1



FAN FLOW RATE AND EFFICIENCY GRAPHS

COD. ACC500009

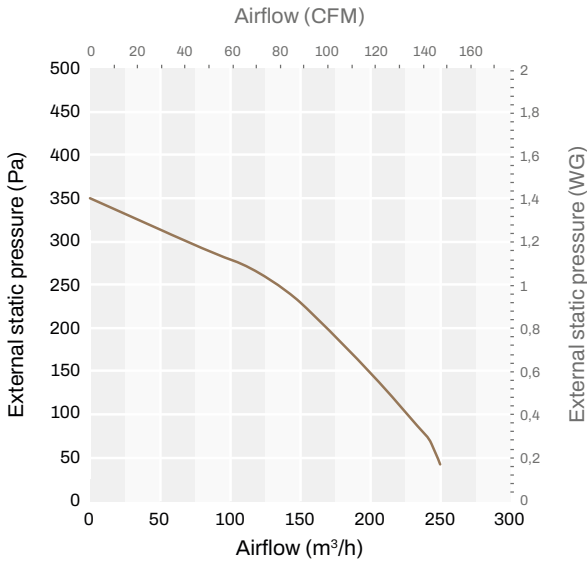

COD. ACC500010

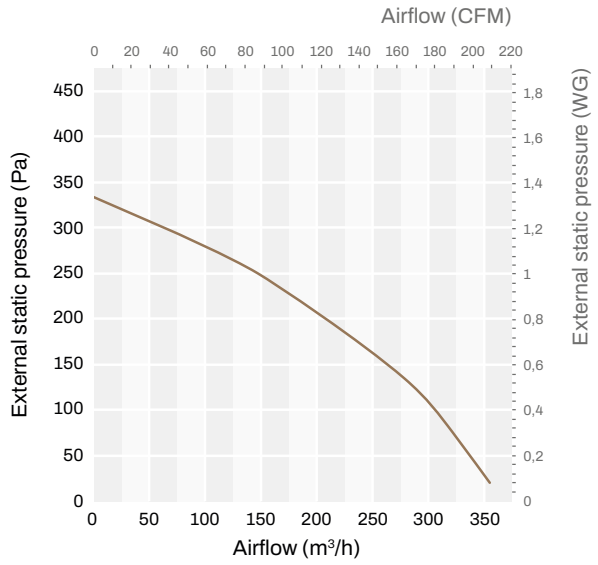

COD. ACC500011

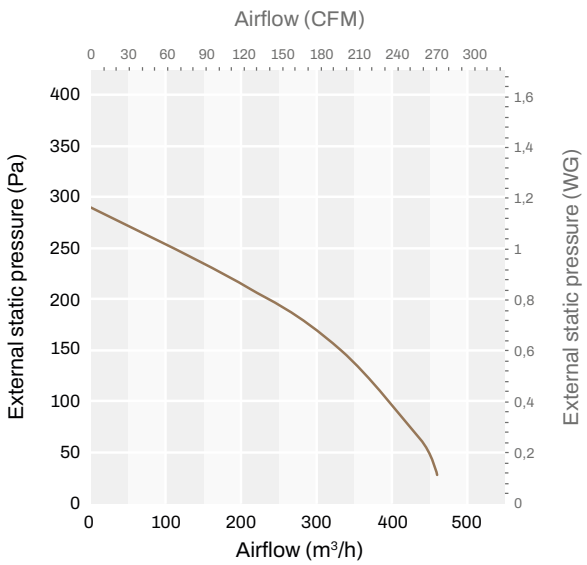

COD. ACC500012

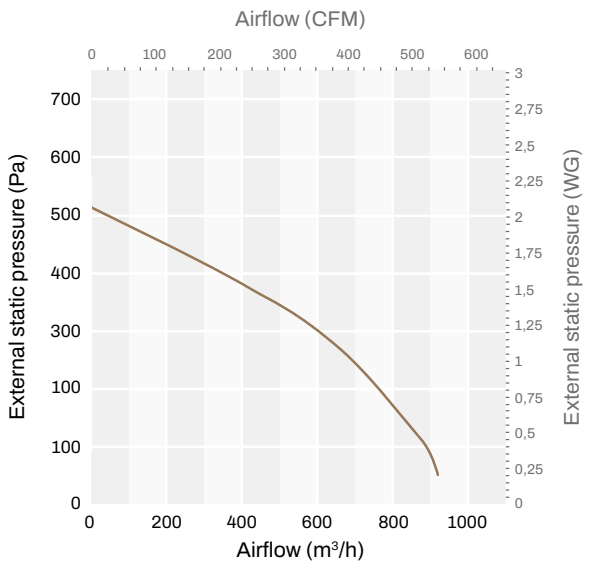

COD. ACC500011

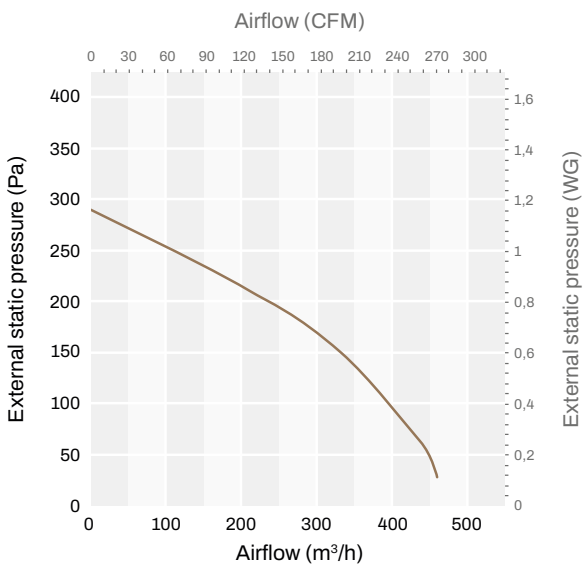

 **REGULATOR FOR IN-LINE FAN FOR CIRCULAR DUCT**

TECHNICAL SPECIFICATIONS

- Power supply: 230 V - 50 Hz
- Maximum current: 1.8 A
- Maximum load connectable: 400 VA
- Dimensions 78*78*63 mm
- Weight: 250 g
- Installation protection rating (only from front panel): IP40

The temperature required for normal operation should be between 0°C and +35°C with relative humidity not greater than 80%.

 **RÉGULATEUR POUR VENTILATEUR EN LIGNE POUR GOULOTTE CIRCULAIRE**

CARACTÉRISTIQUES TECHNIQUES

- Alimentation électrique: 230 V - 50 Hz
- Courant maximal : 1,8 A
- Charge maximale enfichable : 400 VA
- Dimensions 78*78*63 mm
- Poids: 250 g
- Degré de protection: (à partir du panneau avant uniquement): IP40

La température requise pour un fonctionnement normal doit être comprise entre 0°C et +35°C avec une humidité relative ne dépassant pas 80%.

 **REGLER FÜR INLINIE-LÜFTER AUS KREISFÖRMIGEM KANAL**

TECHNISCHE EIGENSCHAFTEN

- Versorgung: 230 V - 50 Hz
 - Max. Stromversorgung: 1,8 A
 - Maximal anschließbare Last: 400 VA
 - Abmessungen 78*78*63 mm
 - Gewicht: 250 g
 - Schutzart (nur von der Frontplatte): IP40
- Die für den normalen Betrieb erforderliche Temperatur muss zwischen 0°C und +35°C bei einer relativen Luftfeuchtigkeit von nicht mehr als 80% liegen.



CE

[Datasheet](#)

CODE	DESCRIPTION	U.M.	 Pieces per box
ACC600088	REGULATOR FOR FAN FOR CIRCULAR DUCTS - "IN LINEA"	PCS	1



 **SMOKE EXTRACTION CAP**

 **CHAPEAU D'ASPIRATION FUMÉES**

 **RAUCHABZUGSKAPPE**

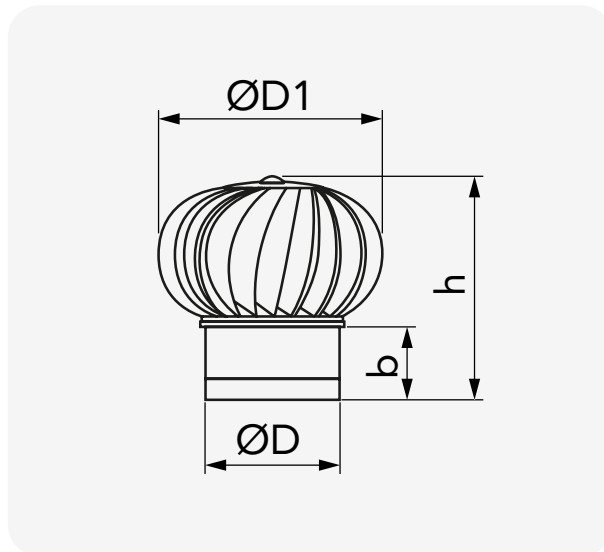

CODE	DESCRIPTION	Ø D [mm]	Ø D1 [mm]	b [mm]	h [mm]	U.M.	 Pieces per box
ACC600017	ROTATING CHIMNEY, Ø100	100	260	100	300	PCS	1
ACC600018	ROTATING CHIMNEY, Ø125	125	260	100	300	PCS	1
ACC600019	ROTATING CHIMNEY, Ø150	150	275	100	300	PCS	1

[Datasheet](#)



DUCTABLE EXTRACTOR WITH VERTICAL OUTPUT

TECHNICAL SPECIFICATIONS

- Easy installation in false ceiling
- 5 air intake couplings
- 1 air expulsion coupling
- Operable via ON / OFF switch (not supplied)
- Recommended for kitchens, bathrooms, offices, shops

ASPIRATEUR CANALISABLE À SORTIE VERTICALE

CARACTÉRISTIQUES TECHNIQUES

- Installation facile dans le faux plafond
- 5 raccords d'admission d'air
- 1 accessoire d'expulsion d'air
- Actionnable via l'interrupteur marche / arrêt (non fourni)
- Recommandé pour les cuisines, salles de bains, bureaux, magasins

KANALISIERBARES SAUGGERÄT MIT VERTIKALEM AUSGANG

TECHNISCHE EIGENSCHAFTEN

- Einfache Montage in Zwischendecke
- 5 Luftansaugstutzen
- 1 Luftaustrittsstutzen
- Bedienung über EIN / AUS-Schalter (nicht mitgeliefert)
- Empfohlen für Küchen, Bäder, Büros, Geschäfte

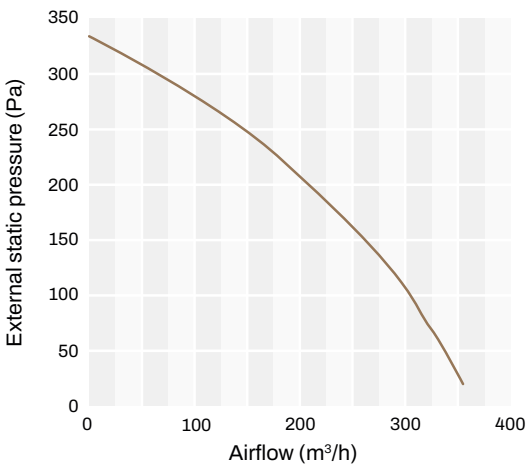
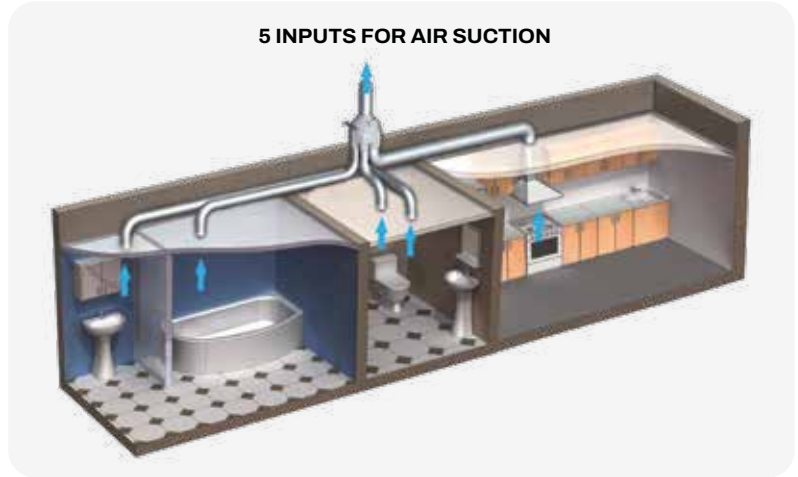

TECHNICAL DATA	
POWER SUPPLY [V]	230
FREQUENCY [Hz]	50
POWER (W)	79
ABSORBED POWER [A]	0,34
AIR FLOW RATE [m³/h]	355
RPM	2800
MAX SOUND LEVEL [dB(A)]	46
MAX OPERATING TEMPERATURE (°C)	- 25 + 55
PROTECTION GRADE	IPX4
DELIVERY TUBE	1 x Ø 125 mm
EXTRACTION PIPE	1 x Ø 125 mm / 4 x Ø 80 mm

Airflow rate 355 m³/h

Fastening support included

Avoids condensation

Datasheet

CODE	DESCRIPTION	U.M.	Pieces per box
30360100	DUCTABLE EXTRACTOR FAN "DUCT PLUS 350"	PCS	1

DUCTABLE EXTRACTOR WITH SIDE OUTPUT

TECHNICAL SPECIFICATIONS

- Easy installation in false ceiling
- Equipped with 1 ejection hole and 4 intake holes
- Made of electro-galvanised painted metal sheet
- Pipe couplings Ø 100 mm
- Operable via switch
- Recommended for extracting air from multiple environments such as kitchens, bathrooms, shops, offices

ASPIRATEUR CANALISABLE AVEC SORTIE LATÉRALE

CARACTÉRISTIQUES TECHNIQUES

- Installation facile dans le faux plafond
- Équipé d'un trou d'éjection et de 4 trous d'aspiration
- Fabriqué en tôle galvanisée et peinte
- Raccords de tuyauterie Ø 100 mm
- Actionnable par l'intermédiaire d'un interrupteur
- Recommandé pour extraire l'air de plusieurs environnements tels que les cuisines, les salles de bains, les magasins, les bureaux

KANALISIERBARES SAUGGERÄT MIT SEITLICHEM AUSGANG

TECHNISCHE EIGENSCHAFTEN

- Einfache Montage in Zwischendecke
- Mit 1 Auswurfloch und 4 Sauglöchern
- Aus galvanisch verzinktem und lackiertem Blech
- Anschlüsse für Ø 100 mm Rohre
- Über Schalter bedienbar
- Empfohlen zum Abzug von Luft aus verschiedenen Umgebungen wie Küchen, Badezimmern, Geschäften, Büros



TECHNICAL DATA

	1	2	3
SPEED	1	2	3
POWER SUPPLY [V]	230	230	230
POWER [W]	20	26	45
ABSORBED POWER [A]	0,32	0,34	0,4
AIR FLOW RATE [m³/h]	97	138	176
RPM	1400	1800	2600
MAX SOUND LEVEL [dB(A)]	33	36	44
MAX OPERATING TEMPERATURE (°C)	50	50	50
PROTECTION GRADE	IPX4	IPX4	IPX4

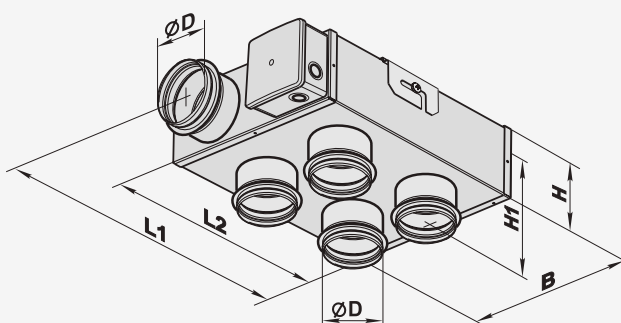
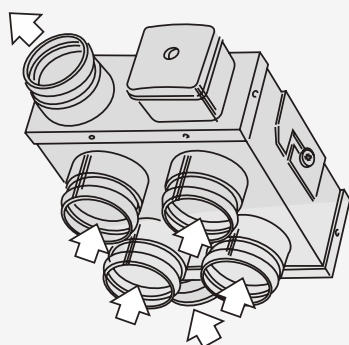

DIMENSIONS [mm]

Ø D [mm]	B [mm]	H [mm]	H1 [mm]	L1 [mm]	L2 [mm]	WEIGHT [kg]
99	260	110	170	302	253	3,4

Datasheet

CODE	DESCRIPTION	U.M.	Pieces per box
11104039	DUCTED EXTRACTOR "DUCT PLUS 180"	PCS	1



GUIDE TO CHOOSING THE RIGHT EXTRACTOR

To choose the appropriate extractor suited to an environment, you must first know the cubic metres to serve. Then you must multiply the volume (cubic m) by four times, which is the recommended number of hourly air exchanges. You will obtain the hourly cubic metres of air that the extractor must extract from the room every hour.

EXAMPLE FOR CALCULATING AN EXTRACTOR SIZE:

Room dimensions: 6 x 4 m = 24 m²

Volume: 24 m³ x 2.70 m (ALTEZZA) = 64.8 m³

Extractor flow rate: 64.8 m³ x 4 = 259.2 m³/h

In this case, you must choose an extractor having a capacity of 259 m²/h.

ROOM-VENTILATION PRINCIPLES IN COMPLIANCE WITH UNI-CIG

THERMAL POWER (KW)

Gas appliances installed for domestic use are required not to exceed 35 kW.

Rooms housing gas appliances that have a naked flame must feature air vents, to allow fresh air in, measuring 6 cm² per kW, for a minimum of 100 cm². Consequently, **if there are various gas appliances in a room**, such as a boiler and cooktop, **the kW of each must be added together and multiplied by 6 (cm²)** to determine the free area of the duct or grille.

FLOW RATE

This is the amount of air that passes through a grille or duct in a unit of time and is measured in m³/h

Flow rate depends on: **free area sq m** and **air velocity m/s**

ACCORDING TO THE EQUATION $QV = 0,36 \times V \times S = M2/H$

Example: air velocity: 4 m/s (V)

Grille free area: 120 cm² (S)

Flow rate qv = 0,36 x 120 (S) 4 (V) = 172,8 m³/h

VENTILATION

Refers to a flow of air that is vital to combustion in appliances that have a naked flame and are fitted with ducting to carry flue gases outside.

AERATION

Refers to a supply of fresh air that is essential for removing combustion residues so as to avoid hazardous unburned gas mixtures in rooms housing gas appliances that are not ducted to the outside.

PRESSURE DROPS

Refers to all those factors that can give rise to obstructions along the path of air flow, affecting the flow rate, such as ducting length or the shape of the grille.

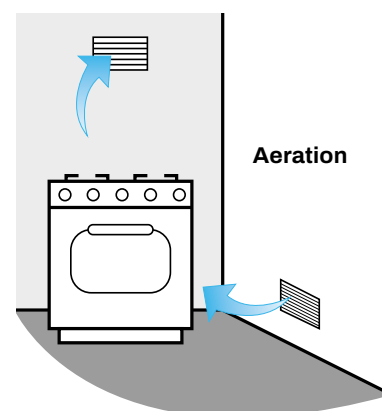
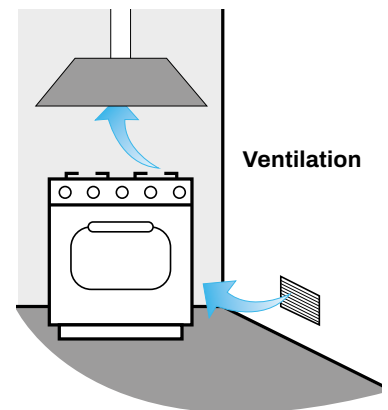

 **"EVEN-T" ELECTRIC EXTRACTOR**

TECHNICAL SPECIFICATIONS

- Made of ABS
- Fastening by means of hidden screws
- 7-blade fan
- Designed for ventilation of medium to small rooms
- Equipped with adjustable timer from 2 to 30 minutes
- Option to mount inside ventilation channels

CEILING OR WALL INSTALLATION

 **"EVEN-T" ASPIRATEUR ÉLECTRIQUE**

CARACTÉRISTIQUES TECHNIQUES

- Fabriqué en ABS
- Fixation au moyen de vis cachées
- Ventilateur à 7 pales
- Conçu pour la ventilation des petites et moyennes pièces
- Équipé d'une minuterie réglable de 2 à 30 minutes
- Montage possible à l'intérieur des canaux de ventilation

INSTALLATION AU PLAFOND OU AU MUR

 **"EVEN-T" ELEKTRISCHES SAUGGERÄT**

TECHNISCHE EIGENSCHAFTEN

- Aus ABS
- Befestigung mittels versteckter Schrauben
- 7-Blatt-Lüfter
- Ausgelegt für die Belüftung von mittelgroßen und kleinen Räumen
- Mit Zeituhr einstellbar von 2 bis 30 Minuten
- Mögliche Montage in Lüftungskanälen

DECKEN- ODER WANDMONTAGE

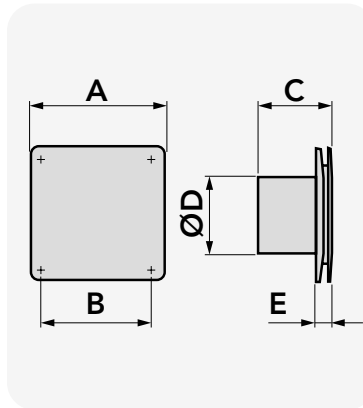

DIMENSIONS [mm]	
A	152
B	120
C	126
Ø D	100
E	30

TECHNICAL DATA		
POWER SUPPLY	[V - Hz]	220 - 50
ABSORBED POWER	[W]	14
CURRENT DEMAND	[A]	0,085
RPM	[R.P.M.]	2300
FAN SPEED	[m³/h]	88
AIR PRESSURE	[Pa]	33
SOUND LEVEL	[dB(A)]	33
WEIGHT	[kg]	0,60

Datasheet

CODE	DESCRIPTION	U.M.	 Pieces per box	
11104028	"EVEN-T" ELECTRIC EXTRACTOR	PCS	1	

 **"LUXURY" ELECTRIC EXTRACTOR**

TECHNICAL SPECIFICATIONS

- Made of ABS
- Fastening by means of hidden screws
- 7-blade fan
- Designed for ventilation of medium to small rooms
- Wall- or ceiling-mounted
- Built-in 12 V LED light

CEILING OR WALL INSTALLATION

 **"LUXURY" ASPIRATEUR ÉLECTRIQUE**

CARACTÉRISTIQUES TECHNIQUES

- Fabriqué en ABS
- Fixation au moyen de vis cachées
- Ventilateur à 7 pales
- Conçu pour la ventilation des petites et moyennes pièces
- Montage mural ou au plafond
- Lumière LED 12 V intégrée

INSTALLATION AU PLAFOND OU AU MUR

 **"LUXURY" ELEKTRISCHES SAUGGERÄT**

TECHNISCHE EIGENSCHAFTEN

- Aus ABS
- Befestigung mittels versteckter Schrauben
- 7-Blatt-Lüfter
- Ausgelegt für die Belüftung von mittelgroßen und kleinen Räumen
- Wand- oder Deckenmontage
- Eingebautes 12V LED-Licht

DECKEN- ODER WANDMONTAGE

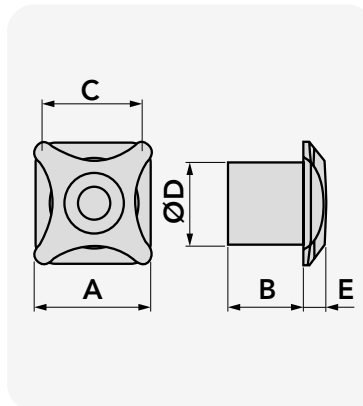

DIMENSIONS [mm]	
A	152
B	95
C	120
Ø D	100
E	36

TECHNICAL DATA		
POWER SUPPLY [V - Hz]		220-50
ABSORBED POWER [W]		16
CURRENT DEMAND [A]		0,085
RPM [R.P.M.]		2300
FAN SPEED [m³/h]		89
AIR PRESSURE [Pa]		31
SOUND LEVEL [dB(A)]		33
WEIGHT [kg]		0,62

Datasheet

CODE	DESCRIPTION	U.M.	 Pieces per box	
11104026	"LUXURY" ELECTRIC EXTRACTOR	PCS	1	

UK "HIGH" ELECTRIC EXTRACTOR

TECHNICAL SPECIFICATIONS

- Made of ABS
- Easy fastening with flat-head screws
- 7-blade fan
- Automatic flap opening
- Ideal for ventilation of small- to medium-sized rooms
- HIGH version that can be operated via a switch
- OPEN T version with adjustable timer option from 2 to 30 minutes
- OPEN TH version with adjustable timer option from 2 to 30 minutes and adjustable humidity sensor in the range of 60 to 90%

CEILING OR WALL INSTALLATION

FR "HIGH" ASPIRATEUR ÉLECTRIQUE

CARACTÉRISTIQUES TECHNIQUES

- Fabriqué en ABS
- Fixation facile avec des vis rétractables
- Ventilateur à 7 pales
- Ouverture automatique du volet
- Idéal pour la ventilation des petites et moyennes pièces
- Version HIGH actionnable via un commutateur
- Version OPEN T avec option de minuterie réglable de 2 à 30 minutes
- Version OPEN TH avec option minuterie réglable de 2 à 30 minutes et capteur d'humidité réglable dans la plage de 60 à 90%

INSTALLATION AU PLAFOND OU AU MUR

DE "HIGH" ELEKTRISCHES SAUGGERÄT

TECHNISCHE EIGENSCHAFTEN

- Aus ABS
- Einfache Befestigung mit verdeckten Schrauben
- 7-Blatt-Lüfter
- Automatisches Öffnen der Klappen
- Ideal für die Belüftung von mittelgroßen und kleinen Räumen
- HIGH-Version, die über einen Schalter bedient werden kann
- OPEN T-Version mit einstellbarer Timer-Option von 2 bis 30 Minuten
- OPEN-TH-VERSION mit einstellbarer Timer-Option von 2 bis 30 Minuten und einstellbarem Feuchtigkeitssensor im Bereich von 60 bis 90 %

DECKEN- ODER WANDMONTAGE

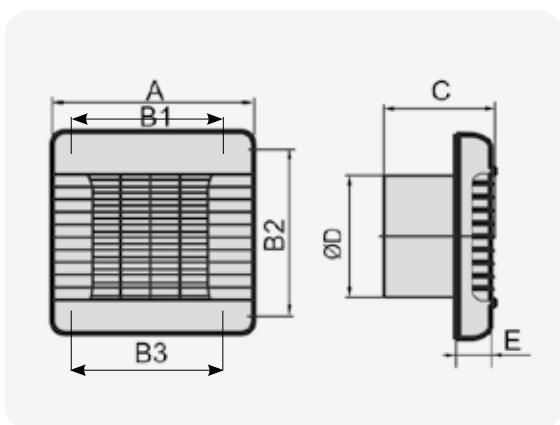

TECHNICAL DATA			
MODEL	Ø 100 mm	Ø 125 mm	Ø 150 mm
POWER SUPPLY [V]	220	220	220
FREQUENCY [HZ]	50	50	50
POWER [W]	18	22	26
ABSORBED CURRENT [A]	0,085	0,1	0,13
AIR FLOW RATE [M³/H]	98	185	295
AIR PRESSURE [PA]	35	55	88
MAX SOUND LEVEL [DB(A)]	34	35	39
SPEED [RPM]	2300	2400	2400
WEIGHT [KG]	0,65	0,75	1,02

DIMENSIONS [mm]							
MODEL	A	B1	B2	B3	C	Ø D	E
HIGH Ø 100	165	150	150	150	92	100	32
HIGH Ø 125	190	128	173	174	98	125	33
HIGH Ø 150	212	150	195	196	114	150	33
HIGH T Ø 100	165	150	150	150	92	100	32
HIGH T Ø 125	190	128	173	174	98	125	33
HIGH T Ø 150	212	150	195	196	114	150	33
HIGH TH Ø 100	165	150	150	150	92	100	32

CODE	DESCRIPTION	U.M.	Pieces per box
11104012	"HIGH" ELECTRIC EXTRACTOR, D.100	PCS	1
11104013	"HIGH" ELECTRIC EXTRACTOR, D.125	PCS	1
11104014	"HIGH" ELECTRIC EXTRACTOR, D.150	PCS	1
11104016	"HIGH T" ELECTRIC EXTRACTOR, D.100	PCS	1
11104017	"HIGH T" ELECTRIC EXTRACTOR, D.125	PCS	1
11104018	"HIGH T" ELECTRIC EXTRACTOR, D.150	PCS	1
11104024	"HIGH TH" ELECTRIC EXTRACTOR, D.100	PCS	1

Datasheet



"OPEN" ELECTRIC EXTRACTOR

TECHNICAL SPECIFICATIONS

- Made of ABS
- Easy fastening with flat-head screws
- 7-blade fan
- Ideal for ventilation of small- to medium-sized rooms
- OPEN version that can be operated via a switch
- OPEN T version with adjustable timer option from 2 to 30 minutes
- OPEN TH version with adjustable timer option from 2 to 30 minutes and adjustable humidity sensor in the range of 60 to 90%

CEILING OR WALL INSTALLATION

"OPEN" ASPIRATEUR ÉLECTRIQUE

CARACTÉRISTIQUES TECHNIQUES

- Fabriqué en ABS
- Fixation facile avec des vis rétractables
- Ventilateur à 7 pales
- Idéal pour la ventilation des petites et moyennes pièces
- Version OPEN actionnable via un interrupteur
- Version OPEN T avec option de minuterie réglable de 2 à 30 minutes
- Version OPEN TH avec option minuterie réglable de 2 à 30 minutes et capteur d'humidité réglable dans la plage de 60 à 90%

INSTALLATION AU PLAFOND OU AU MUR

"OPEN" ELEKTRISCHES SAUGGERÄT

TECHNISCHE EIGENSCHAFTEN

- Aus ABS
- Einfache Befestigung mit verdeckten Schrauben
- 7-Blatt-Lüfter
- Ideal für die Belüftung von mittelgroßen und kleinen Räumen
- OPEN-Version, die über einen Schalter bedient werden kann
- OPEN T-Version mit einstellbarer Timer-Option von 2 bis 30 Minuten
- OPEN-TH-VERSION mit einstellbarer Timer-Option von 2 bis 30 Minuten und einstellbarem Feuchtigkeitssensor im Bereich von 60 bis 90 %

DECKEN- ODER WANDMONTAGE

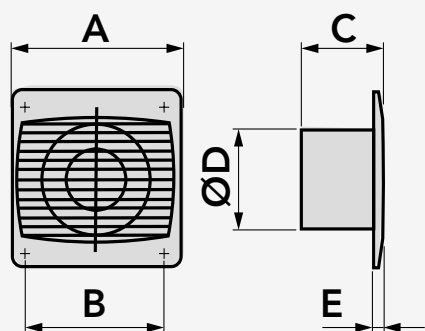

TECHNICAL DATA

MODEL	Ø 100 mm	Ø 125 mm	Ø 150 mm
POWER SUPPLY [V]	220	220	220
FREQUENCY [HZ]	50	50	50
POWER [W]	14	16	24
ABSORBED CURRENT [A]	0,085	0,1	0,13
AIR FLOW RATE [M ³ /H]	95	180	292
AIR PRESSURE [PA]	35	55	86
MAX SOUND LEVEL [DB(A)]	34	35	38
SPEED [RPM]	2300	2400	2400
WEIGHT [KG]	0,58	0,75	1,13

DIMENSIONS [mm]

MODEL	A	B	C	ØD	E
OPEN Ø100	150	120	108	100	12
OPEN Ø125	176	140	114	125	13
OPEN Ø150	205	165	132	150	14
OPEN T Ø100	150	120	108	100	12
OPEN T Ø125	176	140	114	125	13
OPEN T Ø150	205	165	132	150	14
OPEN TH Ø100	150	120	108	100	12
OPEN TH Ø125	176	140	114	125	13
OPEN TH Ø150	205	165	132	150	14

CODE	DESCRIPTION	U.M.	Pieces per box
11104000	"OPEN" ELECTRIC EXTRACTOR, D.100	PCS	1
11104001	"OPEN" ELECTRIC EXTRACTOR, D.125	PCS	1
11104002	"OPEN" ELECTRIC EXTRACTOR, D.150	PCS	1
11104004	"OPEN T" ELECTRIC EXTRACTOR, D.100	PCS	1
11104005	"OPEN T" ELECTRIC EXTRACTOR, D.125	PCS	1
11104006	"OPEN T" ELECTRIC EXTRACTOR, D.150	PCS	1
11104008	"OPEN TH" ELECTRIC EXTRACTOR, D.100	PCS	1
11104009	"OPEN TH" ELECTRIC EXTRACTOR, D.125	PCS	1
11104010	"OPEN TH" ELECTRIC EXTRACTOR, D.150	PCS	1

Datasheet



CIRCLE



"CIRCLE" ELECTRIC EXTRACTOR

TECHNICAL SPECIFICATIONS

- Made of ABS
- Easy fastening with flat-head screws
- Silent 7-blade fan
- Ideal for ventilation of small- to medium-sized rooms
- Operable via switch
- Equipped with anti-insect mesh

CEILING OR WALL INSTALLATION

"CIRCLE" ASPIRATEUR ÉLECTRIQUE

CARACTÉRISTIQUES TECHNIQUES

- Fabriqué en ABS
- Fixation facile avec des vis rétractables
- Ventilateur silencieux à 7 pales
- Idéal pour la ventilation des petites et moyennes pièces
- Actionnable par l'intermédiaire d'un interrupteur
- Équipé d'un filet anti-insectes

INSTALLATION AU PLAFOND OU AU MUR

"CIRCLE" ELEKTRISCHES SAUGGERÄT

TECHNISCHE EIGENSCHAFTEN

- Aus ABS
- Einfache Befestigung mit verdeckten Schrauben
- Geräuscharmer 7-Blatt-Lüfter
- Ideal für die Belüftung von mittelgroßen und kleinen Räumen
- Über Schalter bedienbar
- Mit Insektenschutzgitter

DECKEN- ODER WANDMONTAGE



DIMENSIONS [mm]

MODEL	A	B	C	ØD	ØD1
CIRCLE Ø 100	13	104	102	100	141
CIRCLE Ø 125	15	110	127	150	188
CIRCLE Ø 150	15	125	152	150	188

CODE	DESCRIPTION	U.M.	Pieces per box	Datasheet
11104040	"CIRCLE" ELECTRIC EXTRACTOR, D.100	PCS	1	
11104041	"CIRCLE" ELECTRIC EXTRACTOR, D.125	PCS	1	
11104042	"CIRCLE" ELECTRIC EXTRACTOR, D.150	PCS	1	

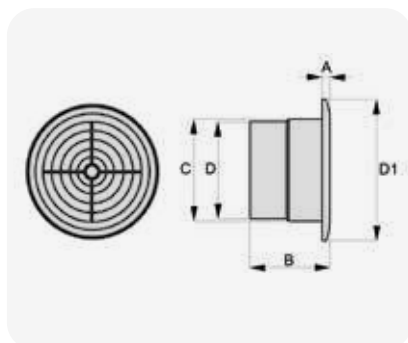

TECHNICAL DATA [mm]

MODEL	Ø 100	Ø 125	Ø 150
POWER SUPPLY [V]	220	220	220
FREQUENCY [HZ]	50	50	50
POWER CONSUMPTION [W]	14	16	24
ABSORBED CURRENT [A]	0,085	0,1	0,13
AIR FLOW RATE [M³/H]	98	185	292
AIR PRESSURE [PA]	33	55	86
MAX SOUND LEVEL [DB(A)]	34	35	38
SPEED [RPM]	2300	2400	2400
WEIGHT [KG]	0,47	0,58	0,90

SOTTOCAPPA



"SOTTOCAPPA" ELECTRIC EXTRACTOR

TECHNICAL SPECIFICATIONS

- Made of ABS
- Ideal for forced odour intake
- Operable via switch
- For both delivery and intake

CEILING OR WALL INSTALLATION

"SOTTOCAPPA" ASPIRATEUR ÉLECTRIQUE

CARACTÉRISTIQUES TECHNIQUES

- Fabriqué en ABS
- Idéal pour l'aspiration forcée des odeurs
- Actionnable par l'intermédiaire d'un interrupteur
- Tant pour l'utilisation de l'alimentation que pour la récupération

INSTALLATION AU PLAFOND OU AU MUR

"SOTTOCAPPA" ELEKTRISCHES SAUGGERÄT

TECHNISCHE EIGENSCHAFTEN

- Aus ABS
- Ideal für forcierte Geruchsabsaugung
- Über Schalter bedienbar
- Sowohl für die Zuluft, als auch die Abluft zu verwenden

DECKEN- ODER WANDMONTAGE

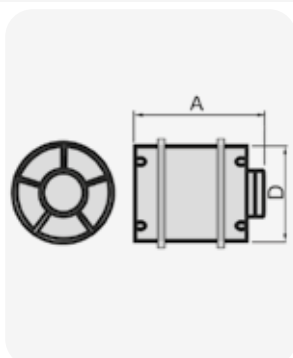

TECHNICAL DATA [mm]

MODEL	Ø 100	Ø 125	Ø 150
POWER SUPPLY [V] - [HZ]	230-50	230-50	230-50
POWER [W]	14	16	29
ABSORBED CURRENT [A]	0,085	0,1	0,13
EXTRACTION CAPACITY [M³/H]	107	190	305
AIR PRESSURE [PA]	41	60	95
MAX SOUND LEVEL [DB(A)]	36	38	40
SPEED [RPM]	2300	2400	2400
PROTECTION RATING	IPX4	IPX4	IPX4
WEIGHT [KG]	0,41	0,43	0,80

DIMENSIONS [mm]

MODEL	A	ØD
SOTTOCAPPA Ø 100	110	100
SOTTOCAPPA Ø 125	118	125
SOTTOCAPPA Ø 150	128	150

CODE	DESCRIPTION	U.M.	Pieces per box	Datasheet
11104030	"SOTTOCAPPA" ELECTRIC EXTRACTOR, D.100	PCS	1	
11104031	"SOTTOCAPPA" ELECTRIC EXTRACTOR, D.125	PCS	1	
11104032	"SOTTOCAPPA" ELECTRIC EXTRACTOR, D.150	PCS	1	

UK "WINDOW" ELECTRIC EXTRACTOR

TECHNICAL SPECIFICATIONS

- Made of ABS
- Automatic flap opening
- Recommended for extracting air from kitchens, shops, offices and restaurants
- Ideal for mounting on windows or glazing
- Equipped with adjustable timer option from 2 to 30 minutes

FR "WINDOW" ASPIRATEUR ÉLECTRIQUE

CARACTÉRISTIQUES TECHNIQUES

- Fabriqué en ABS
- Ouverture automatique du volet
- Recommandé pour extraire l'air des cuisines, des magasins, des bureaux et des restaurants
- Idéal pour le montage de fenêtres et vitraux
- Équipé d'une minuterie réglable de 2 à 30 minutes

DE ELEKTRISCHES SAUGGERÄT

TECHNISCHE EIGENSCHAFTEN

- Aus ABS
- Automatisches Öffnen der Klappen
- Empfohlen zum Abzug von Luft aus Küchen, Geschäften, Büros und Restaurants
- Ideal für die Fenster- und Glasfrontmontage
- Mit Timer-Option, einstellbar von 2 bis 30 Minuten

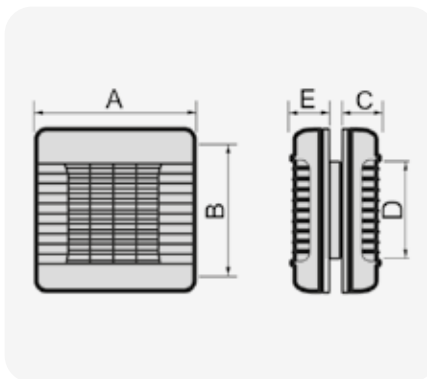

TECHNICAL DATA [mm]		
MODEL	Ø 125	Ø 150
POWER SUPPLY [V]-[HZ]	230-50	230-50
POWER [W]	22	26
ABSORBED CURRENT [A]	0,100	0,130
AIR FLOW RATE [M³/H]	185	295
AIR PRESSURE [PA]	55	80
MAX SOUND LEVEL [DB(A)]	35	41
SPEED [RPM]	2400	2400
WEIGHT [KG]	1,15	1,53

CODE	DESCRIPTION	U.M.	 Pieces per box	DIMENSIONS [mm]					
				MODEL	A	B	C	D	E
11104034	"WINDOW" ELECTRIC EXTRACTOR, D.125	PCS	1	WINDOW Ø125	190	173	53	125	58
11104035	"WINDOW" ELECTRIC EXTRACTOR, D.150	PCS	1	WINDOW Ø150	212	195	60	150	66

Datasheet

UK DUCTABLE CENTRIFUGAL ELECTRIC EXTRACTOR

TECHNICAL SPECIFICATIONS

- Made of ABS
- Easy installation and maintenance
- Protection rating: IP 24
- Operable via switch
- Gravity-operated rear flap opening / closure
- Supplied with fan protection filter

CEILING OR WALL INSTALLATION

FR ASPIRATEUR ÉLECTRIQUE CENTRIFUGE CANALISABLE

CARACTÉRISTIQUES TECHNIQUES

- Fabriqué en ABS
- Installation et entretien faciles
- Degré de protection : IP 24
- Actionnable par l'intermédiaire d'un interrupteur
- Ouverture / fermeture du volet arrière par gravité
- Livré avec filtre de protection de ventilateur

INSTALLATION AU PLAFOND OU AU MUR

DE KANALISIERBARER ELEKTRISCHER ZENTRIFUGALSAUGER

TECHNISCHE EIGENSCHAFTEN

- Aus ABS
- Einfache Montage und Wartung
- Schutzart: IP 24
- Über Schalter bedienbar
- Öffnen / Schließen der hinteren Rippe durch Schwerkraft
- Lieferung mit Lüfterschutzfilter

DECKEN- ODER WANDMONTAGE

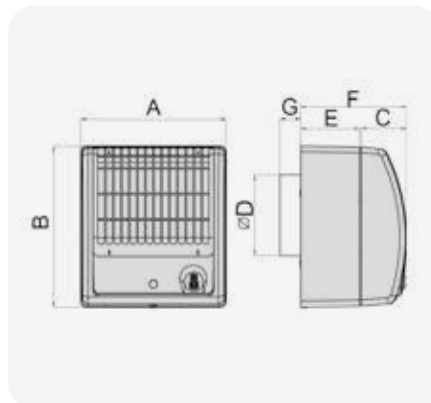

TECHNICAL DATA [mm]	
POWER SUPPLY [V]-[HZ]	220-50
POWER [W]	22
ABSORBED CURRENT [A]	0,17
AIR FLOW RATE [M³/H]	122
AIR PRESSURE [PA]	128
MAX SOUND LEVEL [DB(A)]	38
SPEED [RPM]	2500
WEIGHT [KG]	1,3

CODE	DESCRIPTION	U.M.	 Pieces per box	DIMENSIONS [mm]						
				A	B	C	ØD	E	F	G
11104029	DUCTED ELECTRIC CENTRIFUGAL EXTRACTOR	PCS	1	180	195	59	100	73	132	26

Datasheet

NEW SPARE PARTS CATALOGUE 2025



SCAN THE
QR CODE





CODE	PAG.
11104000	112
11104001	112
11104002	112
11104004	112
11104005	112
11104006	112
11104008	112
11104009	112
11104010	112
11104012	111
11104013	111
11104014	111
11104016	111
11104017	111
11104018	111
11104024	111
11104026	110
11104028	110
11104029	114
11104030	113
11104031	113
11104032	113
11104034	114
11104035	114
11104039	108
11104040	113
11104041	113
11104042	113
11104110	102
11104120	102
11104130	102
11161601	68
12500040	60
12500050	57
12500070	60
12500080	57
12500140	57
12500160	60
12500200	57
12500220	60
12500230	57
12500280	60
12500290	57
12500340	60
12500350	57
12501000	64

CODE	PAG.
12501010	64
12501020	64
30100042	85
30100044	85
30100046	85
30100090	80
30100120	80
30100130	81
30100140	82
30100150	82
30100160	81
30100170	81
30100180	81
30100190	81
30100200	80
30100210	81
30100220	82
30100240	82
30100250	81
30100260	81
30100270	81
30100300	95
30100310	95
30100600	96
30100620	96
30100640	96
30100660	96
30100680	96
30100700	96
30100800	94
30100820	94
30100840	94
30100860	94
30100920	94
30100940	94
30101010	83
30101030	83
30101040	83
30101050	83
30101060	84
30101070	84
30101080	84
30101100	84
30200010	68
30200050	74
30360010	75

CODE	PAG.
30360020	75
30360030	75
30360040	75
30360050	75
30360060	75
30360080	76
30360100	107
30360150	103
30360160	103
30360170	103
30360250	103
30360260	103
30370025	71
30370030	71
30370035	71
30370040	71
30370045	71
30370050	71
30370070	73
30370080	73
ACC200001	54
ACC200002	54
ACC200003	54
ACC200004	54
ACC200005	54
ACC200006	54
ACC200007	54
ACC200008	54
ACC200015	43
ACC200016	43
ACC300009	39
ACC400001	72
ACC400002	72
ACC400003	72
ACC400004	72
ACC400005	73
ACC400006	73
ACC400007	73
ACC400008	73
ACC400009	73
ACC400010	74
ACC400011	74
ACC400012	74
ACC400013	74
ACC400014	74
ACC400015	74

CODE	PAG.
ACC400016	74
ACC400017	70
ACC400018	70
ACC400019	70
ACC400020	70
ACC400021	70
ACC400022	70
ACC400023	70
ACC400024	70
ACC400025	70
ACC400026	70
ACC500009	104
ACC500010	104
ACC500011	104
ACC500012	104
ACC500013	104
ACC600017	106
ACC600018	106
ACC600019	106
ACC600021	79
ACC600022	79
ACC600033	80
ACC600034	80
ACC600035	77
ACC600036	77
ACC600037	78
ACC600038	78
ACC600039	78
ACC600040	78
ACC600041	79
ACC600042	79
ACC600043	84
ACC600044	97
ACC600045	97
ACC600049	97
ACC600050	97
ACC600088	106
ACC600089	100
ACC600090	100
ACC600091	100
ACC600092	100
ACC600093	100
ACC600094	69
ACC600095	69
ACC600096	69
ACC600097	69

CODE	PAG.
ACD100052	25
ACD100053	25
ACD100054	25
ACD100056	23
ACD100057	23
ACD100058	23
ACD100060	21
ACD100061	21
ACD100062	21
ACD200005	31
ACD200006	31
ACD200007	31
ACD200008	34
ACD200009	34
ACD200010	34
ACD200014	32
ACD200015	32
ACD200016	32
ACD200017	35
ACD200018	35
ACD200019	35
ACD200064	41
ACD200065	43
ACD200066	48
ACD200067	48
ACD200068	48
ACD200069	48
ACD200070	48
ACD200071	48
ACD200072	48
ACD200073	48
ACD200074	48
ACD200075	48
ACD300002	65
ACD300003	65
ACD300004	65
ACD300005	65
ACD300006	65
ACD600001	88
ACD600002	88
ACD600003	88
ACD600004	88
ACD600007	89
ACD600010	89
ACD600013	89
ACD600016	89
ACD600019	89
ACD600027	77
ACD600028	77
ACD600039	96
ACD600040	96
ACD600041	96

CODE	PAG.
ACD600042	96
ACD600043	96
ACD600044	96
ACD600045	96
ACD600046	96
ACD600047	96
ACD600048	96
ACD600049	96
ACD600050	96
ACD600051	96
ACD600052	96
ACD600053	94
ACD600054	94
ACD600055	94
ACD600056	94
ACD600057	94
ACD600058	94
ACD600071	95
ACD600072	95
ACD600073	95
ACD600074	95
ACD600083	101
ACD600083	101
ACD600084	101
ACD600084	101
ACD600085	97
ACD600086	97
ACD600088	100
ACD600089	100
ACD600090	100
ACD600092	100
ACD600107	90
ACD600108	90
ACD600109	90
ACD600110	90
ACD600111	90
ACD600112	90
ACD600113	90
ACD600114	91
ACD600115	91
ACD600116	91
ACD600117	91
ACD600118	91
ACD600119	91
ACD600120	91
ACD600121	86
ACD600122	86
ACD600123	86
ACD600124	86
ACD600125	86
ACD600126	86
ACD600127	86

CODE	PAG.
ACD600128	87
ACD600128	87
ACD600129	87
ACD600129	87
ACD600130	87
ACD600130	87
ACD600131	87
ACD600131	87
ACD600132	87
ACD600132	87
ACD600133	87
ACD600133	87
ACD600134	87
ACD600134	87
ACD600137	93
ACD600138	93
ACD600139	93
ACD600140	93
ACD600141	93
ACD600142	93
ACD600143	93
ACD600144	93
ACD600145	93
ACD600146	93
ACD600157	100
ACD600158	92
ACD600159	92
ACD600160	92
ACD600161	92

NEW PRODUCTS

