

TOTAL AIR 200

analysable high-efficiency ceiling-mounted static heat recovery unit with automatic mechanical by-pass

ACD200065 - ACC200015 - ACC200016



TECHNICAL SPECIFICATIONS:

- For false ceiling installation
- Power supply 230V - 50Hz
- Centrifugal EC motors
- Removable grade G4 filters
- Ø 150 mm couplings
- High-efficiency polystyrene heat exchanger pack
- Removable delivery and intake filters
- Equipped with coupling for condensate drain
- Equipped with automatic bypass activation
- Includes wall-mounted control panel with dirty filter alert

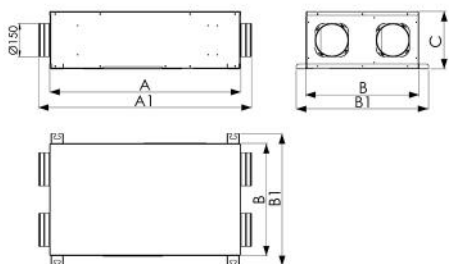

DIMENSIONS

CODE	A [mm]	A1 [mm]	B [mm]	B1 [mm]	C [mm]
ACD200065	850	948	500	589	257

ELECTRICAL AND PERFORMANCE DATA

SPECIFICATIONS	DATA
Type	Unità di ventilazione Residenziale Bidirezionale
Power Supply	230 V - 50 Hz
Electrical power input at maximum flow rate [W]	85
Maximum flow rate (a 100 Pa) [m³/h]	215
Thermal efficiency of the exchange pack	85%
ENERGY RATING (Class SEC temperate climate)	A
Type of heat recovery	Recovery
Type of control	Local environmental control

TECHNICAL SPECIFICATIONS HEAT RECOVERY UNIT

SPECIFICATIONS	DATA
Body material	Electro-galvanised-plated sheet
Insulation	Closed-cell polyethylene 3 mm
Filter: delivery/intake	G4
Duct diameter [mm]	150
Type of heat recovery unit	Cross-flow

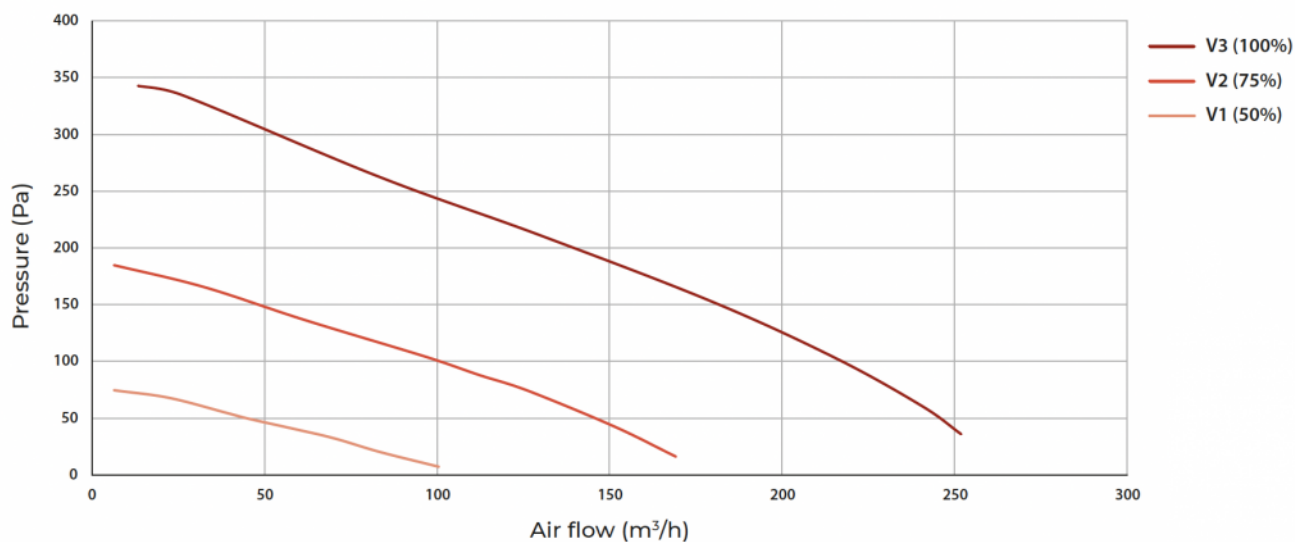

HEAT RECOVERY UNIT INSTALLATION DIAGRAM

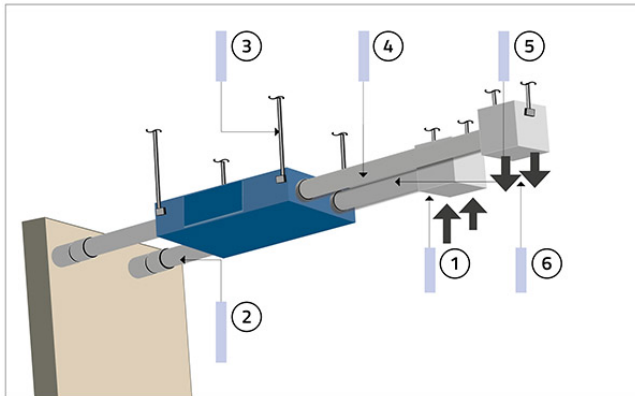

- [1] Air intake
- [2] Intake duct from the outside
- [3] Fastenings of the machine to the ceiling
- [4] Delivery air passage duct
- [5] Recovery air passage duct
- [6] Air delivery

CONTROL PANEL

The "Total Air 200" ceiling-mounted high efficiency heat recovery unit has a wall-mounted control panel with the following functions:



- [1] Operating modes
- [2] Main field
- [3] Manual/automatic fan speed
- [4] Fan speed indication
- [5] Temperature measurement unit
- [6] Function locked
- [7] Set Point
- [8] Time slots active
- [9] Current time slots
- [10] Day of the week
- [10] Dirty filter alarm
- [12] Secondary field

ELECTRICAL CONNECTIONS

The connection required by the heat recovery unit is essentially the power supply connection.

The power is nothing more than the power supply 230V-50Hz-1Ph.

On the power supply line it is good to provide upstream both a disconnector and a differential circuit breaker switch.

OPTIONAL ACCESSORIES

- Advanced configuration terminal for installer (optional)
- Cable for configuring display (optional)



ITEMS

CODE	DESCRIPTION
ACD200065	TOTAL AIR 200 HIGH-EFFICIENCY CEILING-MOUNTED DUCTABLE STATIC HEAT RECOVERY UNIT WITH AUTOMATIC MECHANICAL BY-PASS
ACC200015	ADVANCED SETUP DISPLAY FOR INSTALLERS (OPTIONAL)
ACC200016	CABLE FOR CONFIGURATING DISPLAY