

PICO CLEAN WI

extractor - wall-mounted extractor with external or built-in power supply

ACD100025 - ACD100026 - ACD100027
ACD100028 - ACD100029 - ACD100030

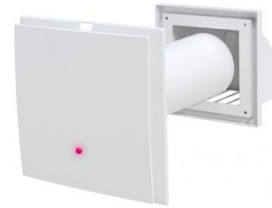

PICO
CLEAN

TECHNICAL SPECIFICATIONS:

- For wall installation
- Panel thickness from the wall 35 mm
- Available with flow rates from 30 to 80 m³/h
- Wi-Fi control mode (offline)
- Humidity threshold can be set to 3 different values: 40 - 50 - 60%
- No condensation formation following operation
- Built-in grade G2 filters
- Fan with low energy consumption
- Suitable for continuous operation
- Equipped with remote control
- Coloured LEDs on panel for settings display
- 3 speeds
- External/built-in power supply 230 V AC supplied
- Minimum installation thickness: 310mm

TECHNICAL DETAILS

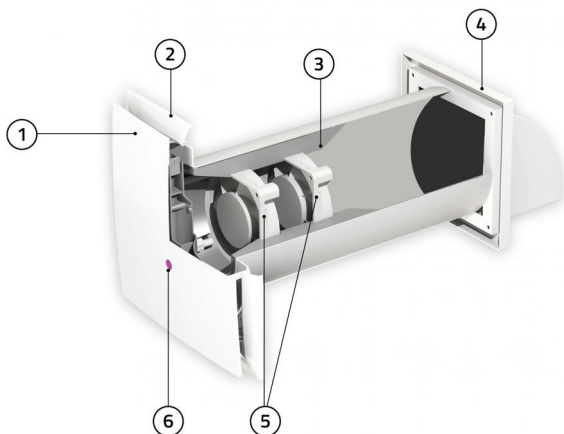

- [1] Aesthetic front panel
- [2] Extraslim grille
- [3] Filter
- [4] External grille
- [5] 3-speed motors
- [6] LED light function

OPERATING MODE

WI-FI MODE

All Pico functions can also be controlled via WI-FI directly from smartphones or tablets in a simple and intuitive way.

USING THE REMOTE CONTROL

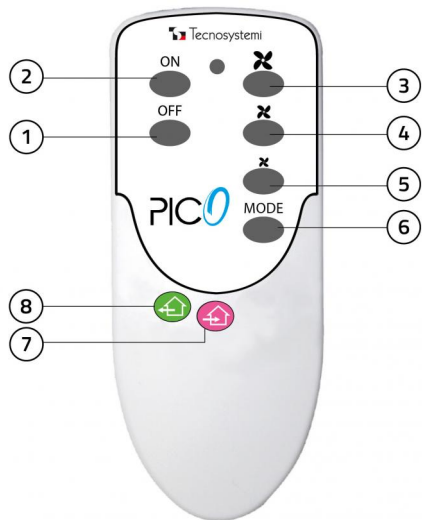

- [1] Fan OFF
- [2] Fan ON
- [3] Maximum speed (humidity value 60%)
- [4] Medium speed (humidity value 50%)
- [5] Low speed (humidity value 40%)
- [6] Change mode
- [7] Delivery
- [8] Extraction

FUNCTIONS OF THE REMOTE CONTROL

EXTRACTION: the system works in internal air extraction only mode, with the possibility to regulate the three speeds.

DELIVERY: the device works in aeration only mode, aspirating external air and introducing it into the room, the possibility of regulating the three speeds is provided.

DIMENSIONS PICO CLEAN 30 - 55 - 80 WI

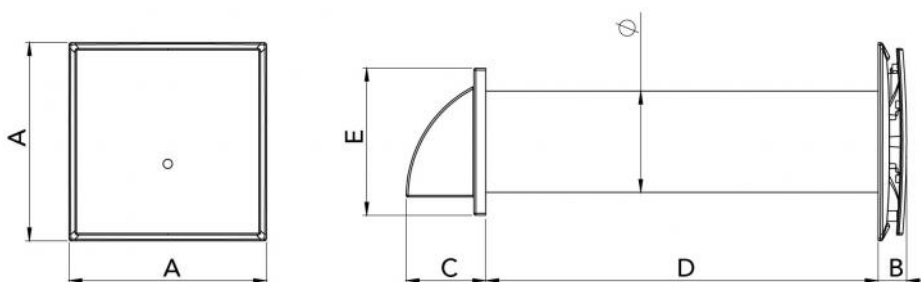

MODELLO	A [mm]	B [mm]	C [mm]	D [mm]	E [mm]	Ø [mm]
CLEAN 30 WI	250	35	86	500	154	103
CLEAN 55 WI	250	35	101	500	186	128
CLEAN 80 WI	250	35	101	500	186	153

PICO CLEAN 30 WI

TECHNICAL DATA	speed min 1	speed min 2	speed min 3
Supply voltage [V]	230	230	230
Power [W]	1,3	1,4	1,4
Current consumed [mA]	38	42	47
Air flow rate [m³/h]	23	25	28
RPM	1863	2070	2300
Sound level 1 m [dB(A)] (min)	32	33	34
Air temperature [°C]	Da -20 a +50	Da -20 a +50	Da -20 a +50
Pipe dimensions [mm]	Ø 103		
Protection rating [IP]	IP 24		

PICO CLEAN 55 WI

TECHNICAL DATA	speed min 1	speed min 2	speed min 3
Supply voltage [V]	230	230	230
Power [W]	1,3	1,6	2,2
Current consumed [mA]	65,5	73	81
Air flow rate [m³/h]	23	35	46
RPM	2106	2340	2600
Sound level 1 m [dB(A)] (min)	29	33	40
Air temperature [°C]	Da -20 a +50		
Pipe dimensions [mm]	Ø 128		
Protection rating [IP]	IP 24		

PICO CLEAN 80 WI

TECHNICAL DATA	speed min 1	speed min 2	speed min 3
Supply voltage [V]	230	230	230
Power [W]	1,7	2,6	3,6
Current consumed [mA]	162	180	200
Air flow rate [m³/h]	39	64	74
RPM	2350	2610	2900
Sound level 1 m [dB(A)] (min)	33	41	46
Air temperature [°C]	Da -20 a +50		
Pipe dimensions [mm]	Ø 153		
Protection rating [IP]	IP 24		

INSTALLATION

The aspirator/extractor was designed for application within premises with a room with wall thicknesses from 310 mm to 500 mm (optional pipe L = 1500 mm) and room temperature varying from -20°C to +50°C and relative humidity of up to 80%.

POWER SUPPLY

The heat recovery unit must be connected to the single-phase 230 V AC - 50 Hz mains by means of the supplied 12 V DC inducement transformer.

To make the connection easier, the recovery unit is supplied with a 2 m long pre-wired power cord.

ITEMS

CODE	DESCRIPTION
ACD100025	"PICO CLEAN 30 WI" WALL-MOUNTED INTAKE/EXTRACTOR FAN WITH EXTERNAL POWER SUPPLY
ACD100026	"PICO CLEAN 55 WI" WALL-MOUNTED INTAKE/EXTRACTOR FAN WITH EXTERNAL POWER SUPPLY
ACD100027	"PICO CLEAN 80 WI" WALL-MOUNTED INTAKE/EXTRACTOR FAN WITH EXTERNAL POWER SUPPLY
ACD100028	"PICO CLEAN 30 WI" WALL-MOUNTED INTAKE/EXTRACTOR WITH BUILT-IN POWER SUPPLY
ACD100029	"PICO CLEAN 55 WI" WALL-MOUNTED INTAKE/EXTRACTOR WITH BUILT-IN POWER SUPPLY
ACD100030	"PICO CLEAN 80 WI" WALL-MOUNTED INTAKE/EXTRACTOR WITH BUILT-IN POWER SUPPLY