

PICO HP2 WI-C-CO2

static extractor unit with wall-mounted heat recovery and with external or built-in power supply - Comfort - CO₂

ACD100013 - ACD100014 - ACD100015
 ACD100016 - ACD100017 - ACD100018
 ACD100050 - ACD100051 - 11161370T



PICO^{wi}
 HP2-C-CO₂

TECHNICAL SPECIFICATIONS:

- For wall installation
- Panel thickness from the wall 35 mm
- Available with flow rates from 30 to 100 m³/h
- Wi-Fi control mode (offline) - comfort - CO₂
- Humidity threshold can be set to 3 different values: 40 - 50 - 60%
- Heat exchanger made of high-efficiency ceramic
- Built-in grade G2 filters
- Fan with low energy consumption
- Suitable for continuous operation
- Equipped with remote control
- Coloured LEDs on panel for settings display
- 3 speeds
- External/built-in power supply 230 V AC supplied
- Minimum installation wall thickness: 310mm

TECHNICAL DETAILS

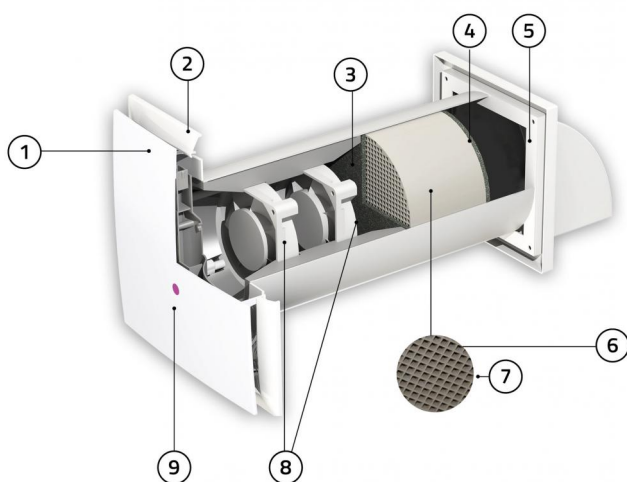

- [1] Aesthetic front panel
- [2] Extraslim grille
- [3] Filter 1
- [4] Filter 2
- [5] External grille
- [6] Exchanger pack
- [7] Detail of the exchanger pack in ceramic material
- [8] 3-speed motors
- [9] LED light function

Pictured is an example of Pico HP2 55

OPERATING MODE

WI-FI MODE

All Pico functions can also be controlled via WI-FI directly from smartphones or tablets in a simple and intuitive way.

COMFORT MODE

The system activates taking advantage of the temperature difference between the external and internal environments, in order

to reach an ideal temperature in the internal environment.

CO₂ MODE

Control CO₂ concentration in your environment, ensuring air that is always fresh and clean.

EASILY CONTROLLED WITH REMOTE CONTROL OR WITH APP OFF-LINE



APP INTERFACE - WI-FI CONTROL MODE (OFFLINE)



All Pico functions can also be controlled via WI-FI directly from your smartphone or tablet in a simple and intuitive way.

Simply activate the function from the device and select Pico WI to access the system.

APP INTERFACE - COMFORT CONTROL MODE



The system, set in Winter Comfort or Summer Comfort mode, is enabled, exploiting the temperature difference between the outdoor and indoor environment, in order to reach an ideal temperature in the indoor environment. You can choose between 3 available speeds.

APP INTERFACE - CONTROL MODE CO₂



By selecting the "Auto 5" and "Auto 6" modes you have the possibility to renew the air of the indoor environment while maintaining a high level of healthiness. You can choose between 3 available speeds.

USING THE REMOTE CONTROL

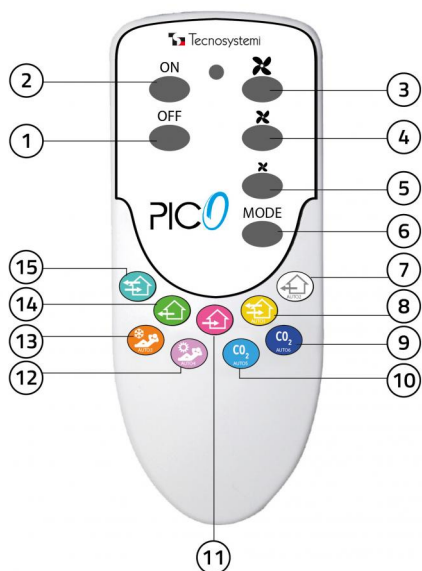

- [1] Fan OFF
- [2] Fan ON
- [3] Maximum speed (humidity value 60%)
- [4] Medium speed (humidity value 50%)
- [5] Low speed (humidity value 40%)
- [6] Change mode
- [7] AUTO 2
- [8] AUTO 1
- [9] AUTO 6
- [10] AUTO 5
- [11] Delivery
- [12] AUTO 4 Winter comfort mode
- [13] AUTO 3 Summer comfort mode
- [14] Extraction
- [15] Air recovery unit

FUNCTIONS OF THE REMOTE CONTROL

HEAT RECOVERY UNIT: the system works for 70 seconds in intake and for 70 seconds in delivery with the possibility to regulate the three speeds.

EXTRACTION: the system works in internal air extraction only mode, with the possibility to regulate the three speeds.

DELIVERY: the device works in aeration only mode, aspirating external air and introducing it into the room, the possibility of regulating the three speeds is provided.

AUTO 1: the system is in standby, when the air in the room exceeds the threshold of humidity; settable at 40%, 50% or 60%, the device starts in recovery mode until the humidity level falls within the set value.

AUTO 2: the system is in standby, when the air in the room exceeds the threshold of humidity; settable at 40%, 50% or 60%, the device starts in extraction only mode until the humidity level falls within the set value.

AUTO 3 - SUMMER COMFORT: the system is in stand-by mode, if the outdoor temperature is lower than the indoor temperature, the heat recovery unit will go into delivery mode at maximum speed; the machine will return to standby when the temperature value is restored.

AUTO 4 - WINTER COMFORT: the system is in stand-by mode, if the outdoor temperature is higher than the indoor temperature, the heat recovery unit will go into delivery mode at maximum speed; the machine will return to standby when the temperature value is restored.

AUTO 5: the system is in stand-by mode, when the threshold of CO₂ (800 ppmv) is exceeded, the heat recovery unit will go into recovery mode at maximum speed, the machine will return to stand-by when the value of CO₂ is restored.

AUTO 6: the system is in standby, when the threshold of CO₂ (800 ppmv) is exceeded, the heat recovery unit will go into extraction mode at full speed, the machine will return to standby when the value of CO₂ is restored.

DIMENSIONS PICO HP2 WI-C-CO₂

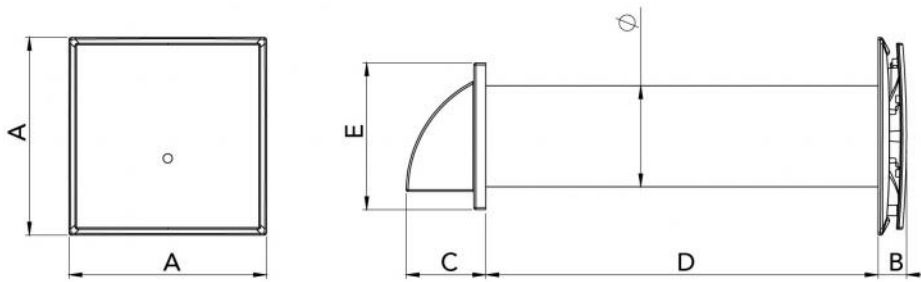

MODELLO	A [mm]	B [mm]	C [mm]	D [mm]	E [mm]	Ø [mm]	
HP2 30 WI-C-CO ₂	250	35	86	500	154	103	
HP2 55 WI-C-CO ₂	250	35	101	500	186	128	
HP2 80 WI-C-CO ₂	250	35	101	500	186	153	

PICO HP2 30 WI-C-CO₂

TECHNICAL DATA	speed min 1	speed min 2	speed min 3
Supply voltage [V]	230	230	230
Power [W]	1,3	1,4	1,4
Current consumed [mA]	38	42	47
Air flow rate [m ³ /h]	23	25	28
RPM	1863	2070	2300
Sound level 1 m [dB(A)] (min)	32	33	34
Air temperature [°C]	Da -20 a +50		
Regenerative efficiency	≤90%		
Material exchanger pack	Ceramic		
Pipe dimensions [mm]	Ø 103		
Protection rating [IP]	IP 24		

PICO HP2 55 WI-C-CO₂

TECHNICAL DATA	speed min 1	speed min 2	speed min 3
Supply voltage [V]	230	230	230
Power [W]	1,3	1,46	2,2
Current consumed [mA]	65,5	73	81
Air flow rate [m ³ /h]	23	35	46
RPM	2106	2340	2600
Sound level 1 m [dB(A)] (min)	29	33	40
Air temperature [°C]	Da -20 a +50		
Regenerative efficiency	≤90%		
Material exchanger pack	Ceramic		
Pipe dimensions [mm]	Ø 128		
Protection rating [IP]	IP 24		

PICO HP2 80 WI-C-CO₂

TECHNICAL DATA	speed min 1	speed min 2	speed min 3
Supply voltage [V]	230	230	230
Power [W]	1,7	2,6	3,6
Current consumed [mA]	162	180	200
Air flow rate [m ³ /h]	39	64	74
RPM	2350	2610	2900
Sound level 1 m [dB(A)] (min)	33	41	46
Air temperature [°C]	Da -20 a +50		
Regenerative efficiency	≤90%		
Material exchanger pack	Ceramic		
Pipe dimensions [mm]	Ø 153		
Protection rating [IP]	IP 24		

DIMENSIONS PICO HP2 100 WI-C-CO₂

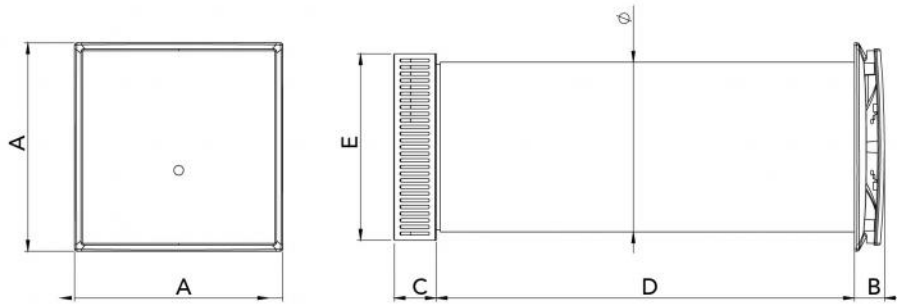

MODELLO	A [mm]	B [mm]	C [mm]	D [mm]	E [mm]	Ø [mm]	
HP2 100 WI-C-CO ₂	250	35	50	500	225	204	

PICO HP2 100 WI-C-CO₂

TECHNICAL DATA	speed min 1	speed min 2	speed min 3
Supply voltage [V]	230	230	230
Power [W]	6,6	7,7	8,4
Current consumed [mA]	550	640	700
Air flow rate [m ³ /h]	70	81	91
RPM	3395	4070	4500
Sound level 1 m [dB(A)] (min)	46	48	50
Air temperature [°C]	Da -20 a +50	Da -20 a +50	Da -20 a +50
Regenerative efficiency	≤90%	≤90%	≤90%
Material exchanger pack	Ceramic		
Pipe dimensions [mm]	Ø 204	Ø 204	Ø 204
Protection rating [IP]	24	24	24

INSTALLATION

The heat recovery unit was designed for application within premises with a room with wall thicknesses from 310 mm to 500 mm (optional pipe L = 1500 mm) and room temperature varying from -20°C to +50°C and relative humidity of up to 80%.

POWER SUPPLY

The heat recovery unit must be connected to the single-phase 230 V AC - 50 Hz mains by means of the supplied 12 V DC inducement transformer.

To make the connection easier, the recovery unit is supplied with a 2 m long pre-wired power cord.

ITEMS

CODE	DESCRIPTION
ACD100013	"COMFORT + CO2 - PICO HP2 30 WI-C CO2" WALL-MOUNTED CROSS FLOW STATIC INTAKE/EXTRACTOR FAN WITH HEAT RECOVERY,EQUIPPED W/ EXTERNAL POWER SUPPLY
ACD100014	"COMFORT + CO2 - PICO HP2 55 WI-C CO2" WALL-MOUNTED CROSS FLOW STATIC INTAKE/EXTRACTOR FAN WITH HEAT RECOVERY,EQUIPPED W/ EXTERNAL POWER SUPPLY
ACD100015	"COMFORT + CO2 - PICO HP2 80 WI-C CO2" WALL-MOUNTED CROSS FLOW STATIC INTAKE/EXTRACTOR FAN WITH HEAT RECOVERY,EQUIPPED W/ EXTERNAL POWER SUPPLY
ACD100016	"COMFORT + CO2 - PICO HP2 30 WI-C CO2" WALL-MOUNTED CROSS FLOW STATIC INTAKE/EXTRACTOR FAN WITH HEAT RECOVERY,EQUIPPED W / BUILT -IN POWER SUPPLY
ACD100017	"COMFORT + CO2 - PICO HP2 55 WI-C CO2" WALL-MOUNTED CROSS FLOW STATIC INTAKE/EXTRACTOR FAN WITH HEAT RECOVERY,EQUIPPED W / BUILT -IN POWER SUPPLY
ACD100018	"COMFORT + CO2 - PICO HP2 80 WI-C CO2" WALL-MOUNTED CROSS FLOW STATIC INTAKE/EXTRACTOR FAN WITH HEAT RECOVERY,EQUIPPED W / BUILT -IN POWER SUPPLY
ACD100050	"PICO HP2 100 WI-C-CO2" WALL-MOUNTED CROSS FLOW STATIC INTAKE/EXTRACTOR FAN WITH HEAT RECOVERY,EQUIPPED W/ EXTERNAL POWER SUPPLY
ACD100051	"PICO HP2 1000 WI-C-CO2" WALL-MOUNTED CROSS FLOW STATIC INTAKE/EXTRACTOR FAN WITH HEAT RECOVERY,EQUIPPED W/ BUILT-IN POWER SUPPLY
11161370T	TT 200 PIPE WITH DEFLECTOR (Ø 200 - LENGTH 1500)