

# SMART FLOW - SF 20 - 30 - 40 It

condensate collection pump

- cod. 12170105 - cod. 12170106 - cod. 12170107

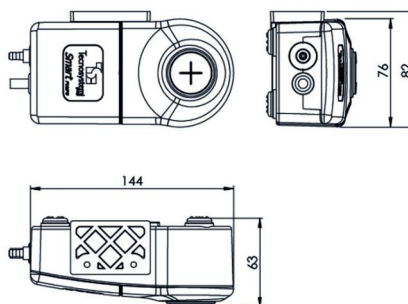

## DESCRIPTION

The condensate collection pump can be used in applications such as:

- column air conditioners;
- refrigerated display cases;
- refrigerated cabinets;
- refrigerated counters;
- evaporators;
- ceiling mounted air conditioners.

An anti-vibration and flexible rubber for wall mounting the pump can be purchased separately.

CAUTION: the SMART FLOW condensate collection pump is not suited for continuous cycle use.

## TECHNICAL SPECIFICATIONS

	TECHNICAL SPECIFICATIONS
Power supply	230V~ - 50 Hz
IP rating	IPX7
Alarm contact C-NO	6A
Operating temperature	from +5 to +45 °C
Condensate temperature	max. +35 °C
Room temperature	max +60°C
Fluid type	water
Type of operation	Intermittent
Thermal protection (overheating)	90°C (automatic restart)
Sound level	from 29 dB(A) to 53 db(A)

## PACKAGE CONTENTS

- 1 pump body

- 1 sheet of instructions

## COMBINATIONS WITH CONDENSATE DRAIN PIPES

SMART FLOW 20	SMART FLOW 30	SMART FLOW 40
Ø4 x 6 mm	Ø6 x 9,25 mm	

### SMART FLOW - SF 20 It

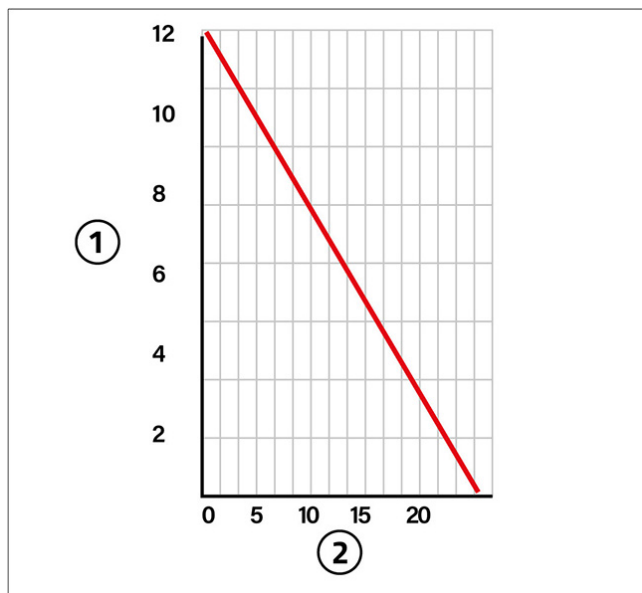

[1] Air delivery (vertical m)  
[2] Flow rate (litres/hour)

- Flow rate 20 l/h for unit up to 20 kW
- Max. 12 m vertical delivery
- Power consumption 19 W
- Max. noise level 29 [dB (A)]
- Pipe dimensions Ø 4 x 6 mm

### SMART FLOW - SF 30 It

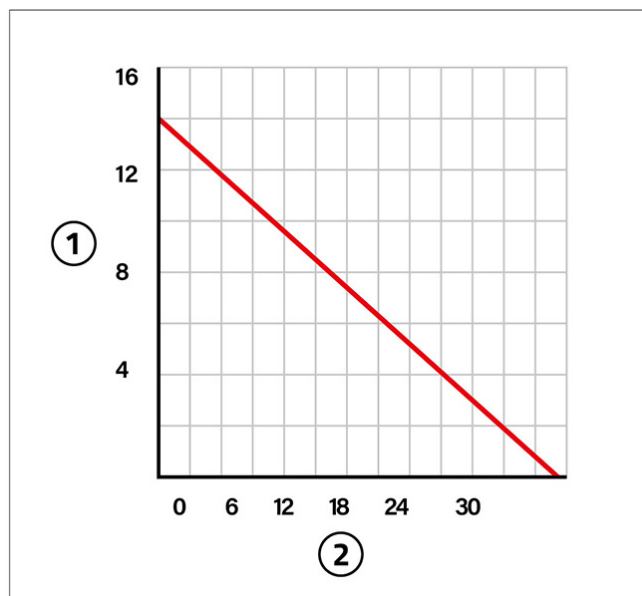

[1] Air delivery (vertical m)  
[2] Flow rate (litres/hour)

- Flow rate 30 l/h for unit up to 30 kW
- Max. 14 m vertical delivery
- Power consumption 25 W
- Max noise level 50 [dB(A)]
- Pipe dimensions Ø 6 x 9,5 mm

## SMART FLOW - SF 40 lt

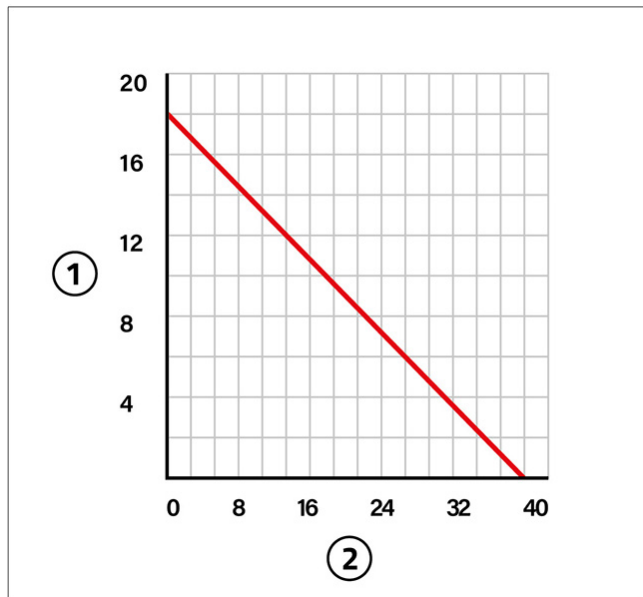

[1] Air delivery (vertical m)  
[2] Flow rate (litres/hour)

- Flow rate 40 l/h for unit up to 40 kW
- Max. 18 m vertical delivery
- Power consumption 27 W
- Max noise level 53 [dB(A)]
- Pipe dimensions  $\varnothing$  6 x 9,5 mm

## ITEMS

12170105	SMART FLOW-SF 20 LT. CONDENSATE COLLECTION PUMP
12170106	SMART FLOW-SF 30 LT. CONDENSATE COLLECTION PUMP
12170107	SMART FLOW-SF 40 LT. CONDENSATE COLLECTION PUMP

All rights relating to this publication are the exclusive property of Tecnosystemi SpA.

Tecnosystemi SpA reserves the right to make changes at any time and without notice, for technical or commercial needs.